

KITA®
www.kita.com.tw

● ● ● **SINCE 1988**
**Professional in
development
and manufacture**

Pressure Sensor
Magnetic Sensor
Connector

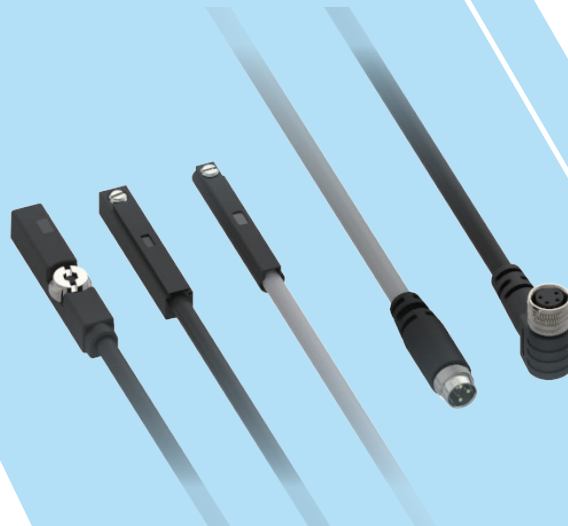

KITA SENSOR TECH. CO., LTD. established in Oct. 1988, located in New Taipei Industrial Park, Wugu Dist., New Taipei City, Taiwan. Producing Hydraulic / Pneumatic magnetic-sensor and pressure-sensor are our major business.

With the efforts in R&D for more than decades in the field of automation, our above-mentioned products have been not only widely accepted by the Taiwan users but also exported to the overseas markets since 1996. Moreover, KITA SENSOR earned ISO 9001 international quality assessment certificate in April 1998 for the quality assurance. **QUALITY GUARANTEED.**

As of Dec. 2000, our products have been distributed accompanied with CE inspection approval to the developed countries : U.S., Europe, Japan, etc. KITA SENSOR persist in satisfying the customer's needs and pursuing the superiority in product's quality through innovation.

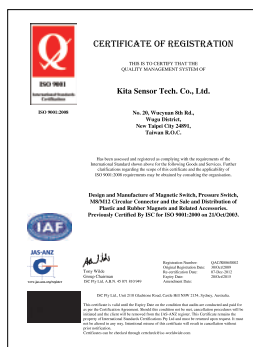

■ TAIWAN / Headquarter

■ TAIWAN / Yilan Factory



■ CHINA / Chang Shu Factory



Introduction to Branch Companies

📍 Overseas Offices

● Overseas Markets





**JAPAN
MING-SHIH INC.**

Our Japanese branch is strategically involved with our marketing development of all of our fluid power accessories and magnetic sensors. We proudly service many factories that currently utilize our magnetic sensors for all of their pneumatic cylinder application.

P.06

Pressure Sensor

Caution	P.07
Application	P.08
Industrial Internet of Things Applications	P.10
KP10 Series	P.12
KP101 / 102 Series	P.18
KP1 Series	P.20
KP30 Series	P.24
KP43 Series	P.28
KP45 Series	P.32
KP45S Series	P.36
KP47 Series	P.40
KP50E Series	P.44
KP60 Series	P.48
KP61 Series	P.50
KP70 Series	P.52
KP75 Series	P.56
KP90 Series	P.60
KP400 Series	P.64
KP610 Series	P.68
KP800 Series	P.72
KP7800 Series	P.76
KDS Series	P.80
KGS Series	P.84
KFP Series	P.88
KF Series	P.92



P.96

Magnetic Sensor

Ordering Information & Connection Method ...	P.97
Cylinder / Magnetic Sensor Cross Index	P.98
Magnetic Sensor Operating & Installing	P.100



Caution	P.101	KT-48 Series	P.124
Hot Sale	P.102	KT-50 Series	P.125
KT-05 Series	P.104	KT-53 Series	P.126
KT-06 Series	P.105	KT-58 Series	P.127
KT-07 Series	P.106	KT-59 Series	P.128
KT-09 Series	P.107	KT-65 Series	P.129
KT-11 Series	P.108	KT-65-EX Series	P.130
KT-13 Series	P.109	KT-65-UL Series	P.131
KT-15 Series	P.110	KT-71 Series	P.132
KT-16 Series	P.111	KT-75 Series	P.133
KT-20 Series	P.112	KT-77 Series	P.134
KT-21 Series	P.113	KT-1000D Weld-field Immune Sensor .	P.135
KT-31 Series	P.114	KT-1001D Weld-field Immune Sensor .	P.137
KT-32 Series	P.115	Bracket	P.138
KT-32-EX Series	P.116	Clamp	P.142
KT-33 Series	P.117	Magnet	P.148
KT-36 Series	P.118		
KT-37 Series	P.119		
KT-38 Series	P.120		
KT-39 Series	P.121		
KT-40 Series	P.122		
KT-47 Series	P.123		



P.149

Circular Connector

M8 □ R Series	P.150
KM8 □ R Series	P.151
M8 □ QD Series	P.152
M8 □ SW Series	P.153
M12 □ R Series	P.154
M12 □ QD Series	P.155



Pressure Sensor

KP10 Series



P.12

KP101 / 102 Series



P.18

KP1 Series



P.20

KP30 Series



P.24

KP43 Series



P.28

KP45 Series



P.32

KP47 Series



P.40

KP60 Series

Patented
Battery Meter



P.48

KP61 Series



P.50

KP70 Series

RS485



P.52

**KP50E **
KP75 Series

RS485



P.44
P.56

KP90 Series



P.60

KP400 Series



P.64

KP610 Series

Differential Pressure Sensor



P.68

KP800 Series

Differential Pressure Sensor



P.72

KP7800 Series

Differential Pressure Sensor
RS485



P.76

KDS Series
Differential Pressure Sensor
RS485



P.80

KGS Series
Gap Sensor



P.84

KFP Series
Flow & Pressure Sensor
RS485



P.88

KF Series
Flow Sensor
RS485



P.92

※ Product surfaces with slight luminance non-uniformity, color cast, tiny scratching, little stains etc. are regarded as qualified products.

Caution

- When using a 2-wire type pressure sensor (KP101 / 102 & KP10A / 10B), please make sure it is connected to a DC power source and a proper resistance load. Otherwise excessive current will damage the sensor permanently.

Always connect the brown wire to the positive (+), blue wire to the negative (-).

Permanent damages to the pressure sensor will occur if the connections are reversed.

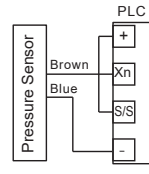
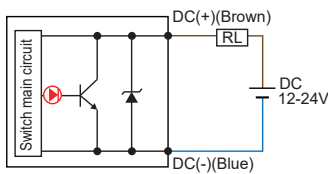

Connection to NPN input module

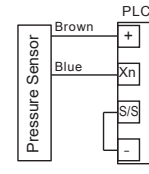
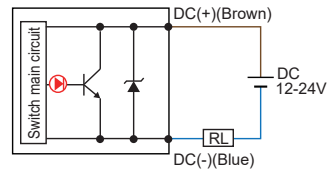

Connection to PNP input module

- To improve stability of the pressure sensor and the whole circuit in general, it is recommended to properly ground the DC power source.

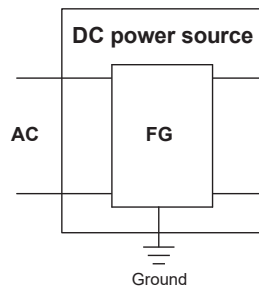

- When using with inductive load (such as relay or solenoid), please install a flyback diode across the load to remove surge and polarity must be observed or damages to pressure sensor may occur.

2 wire switch type

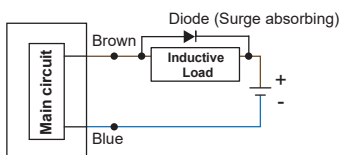

NPN type

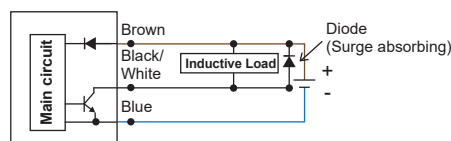

PNP type

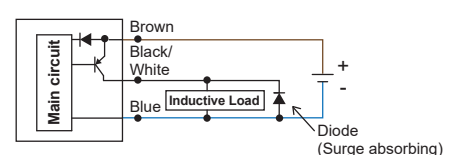

- Before sensor installation or removal, please make sure the power is OFF and pressure in pipe has been released, released to avoid personal injuries, sensor damage or other losses.

- Please separate the power supply of a variable frequency driver or a motor driver from the pressure power supply to avoid noise affect the pressure sensor normal operation.

- The products described in this document are NOT designed for explosion-qualified applications. Do not use the products in flammable gases, liquids or explosive atmospheres. Please use them right by following all the guidelines stated in the user manual to avoid damage and injury.

- Procedure to wiring RS485 products : To prevent product damage due to short circuit ,MUST do RS485 line conneciton BEFORE power line connection.

Application

Detection of Line Pressure

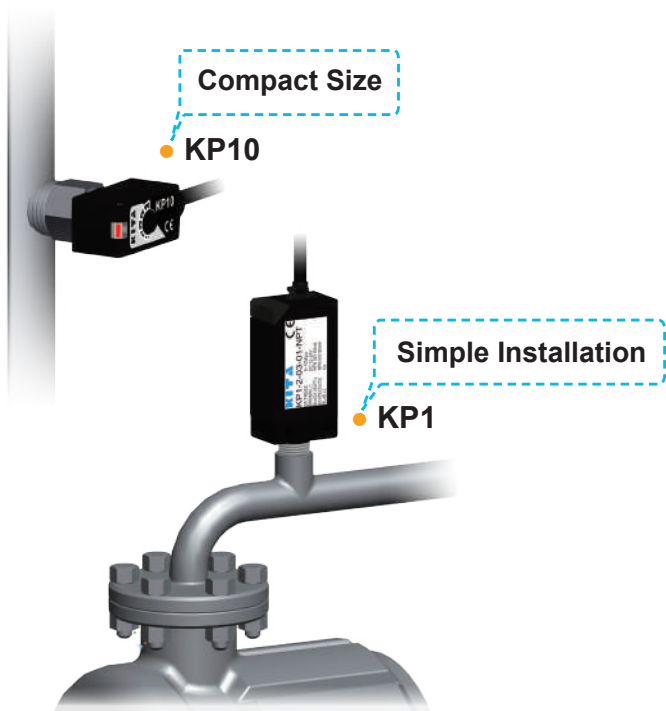

Pressure Display of Line Pressure

- Digital display, easy readout
- Replace traditional pressure gauge

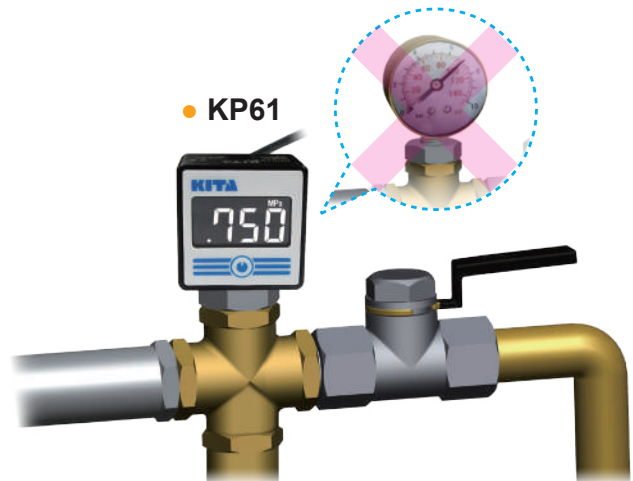

Pressure Display and Control of Pneumatic Equipment

- LCD display
- 2 outputs and 1 analog output (1 ~ 5 V or 4 ~ 20 mA)



Pressure Display and Control of Pressure in Reservoir Tank

- Programmable pressure unit : 6 types
- IP65 enclosure



Pressure Display and Control of Press Machine

- Upright pressure sensor save installation space
- 2 outputs and 1 analog output (1 ~ 5 V)

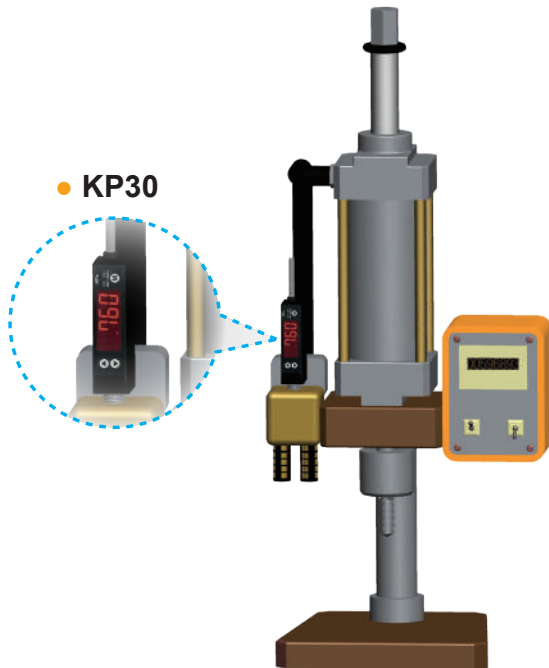

Leakage Test

- 3-color digital display, easy readout



Operation of Suction Pads

- 3-color digital LCD display
- 7 response time for selection
- 2 outputs and 1 analog output (1 ~ 5 V or 4 ~ 20 mA)

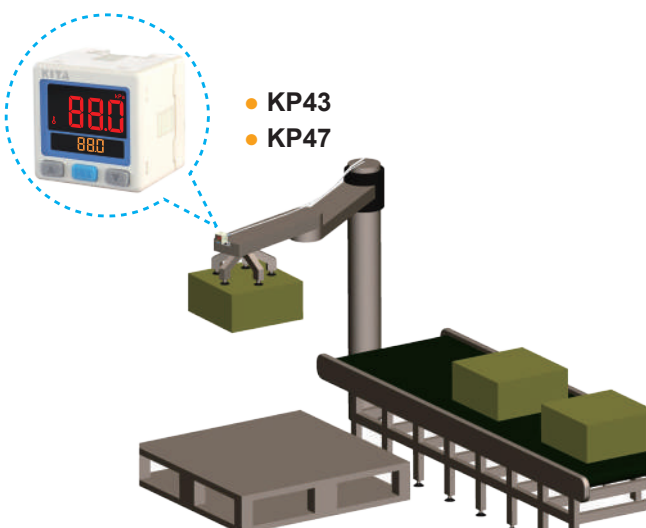

Pressure Display of F.R.L Unit

- Battery type without extra power supply
- 6 pressure units for selection
- IP65 enclosure

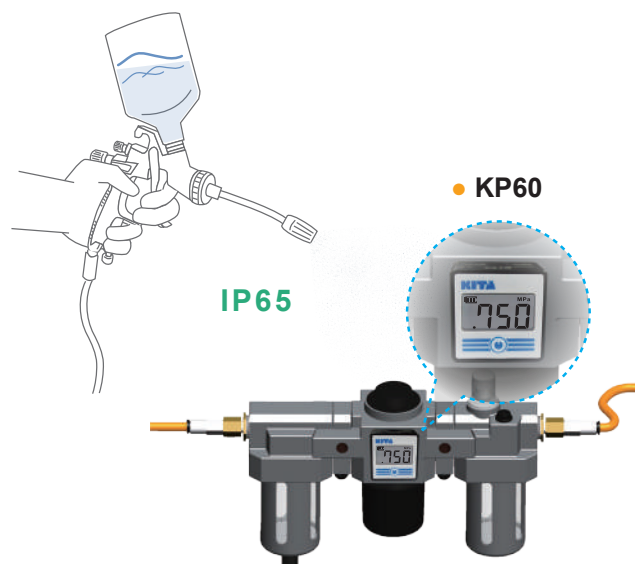

Industrial Internet of Things Applications

Remote Control

A large amount of sensor needs to be set on machine at production line; However, sensor's parameter must be set individually. Is it efficient enough?

► Smart sensors brings these benefits and makes IIOT in practice.

KP70 refer to P.52

KP75 refer to P.56

KP7800 refer to P.76

KDS refer to P.80

KFP refer to P.88

KF refer to P.92

RS485 MODBUS CONTROL

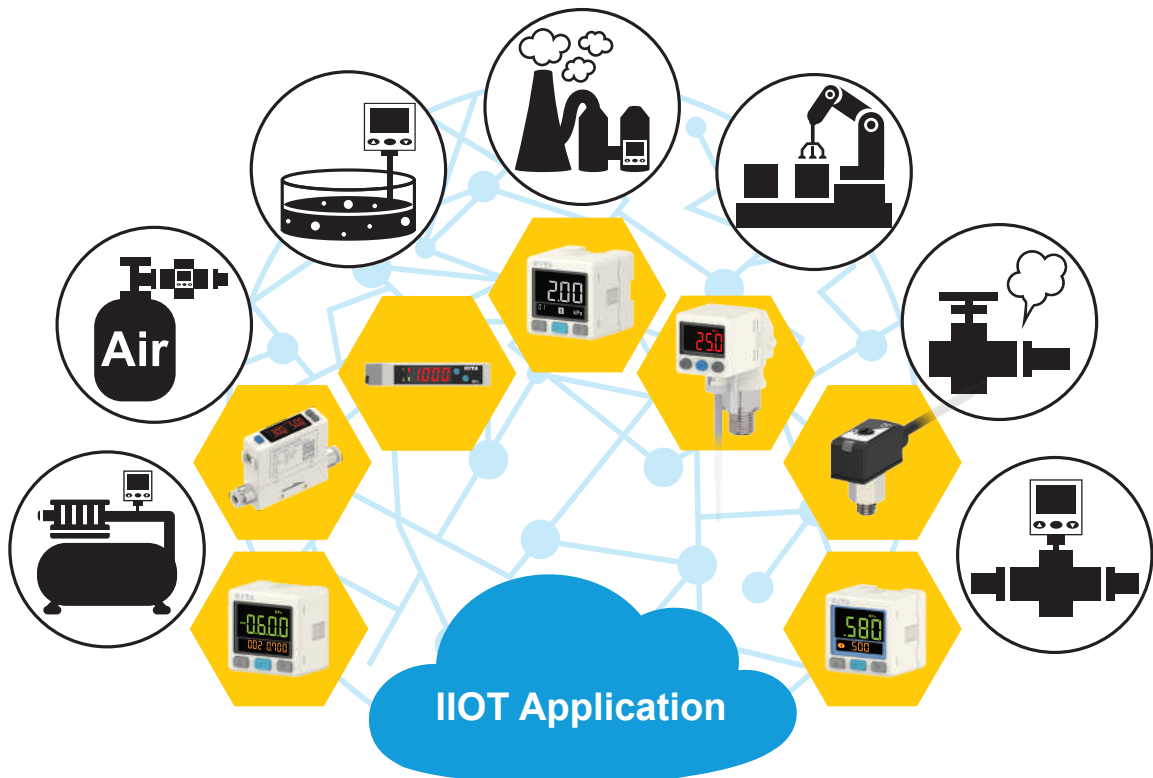

Application

In warehouse moving system, utilizing data-analysis and remote-control to elongate the life span of suction pad that prevent carton fall from robot and damage-cause. Furthermore, all setting can be done on the remote site with one click.

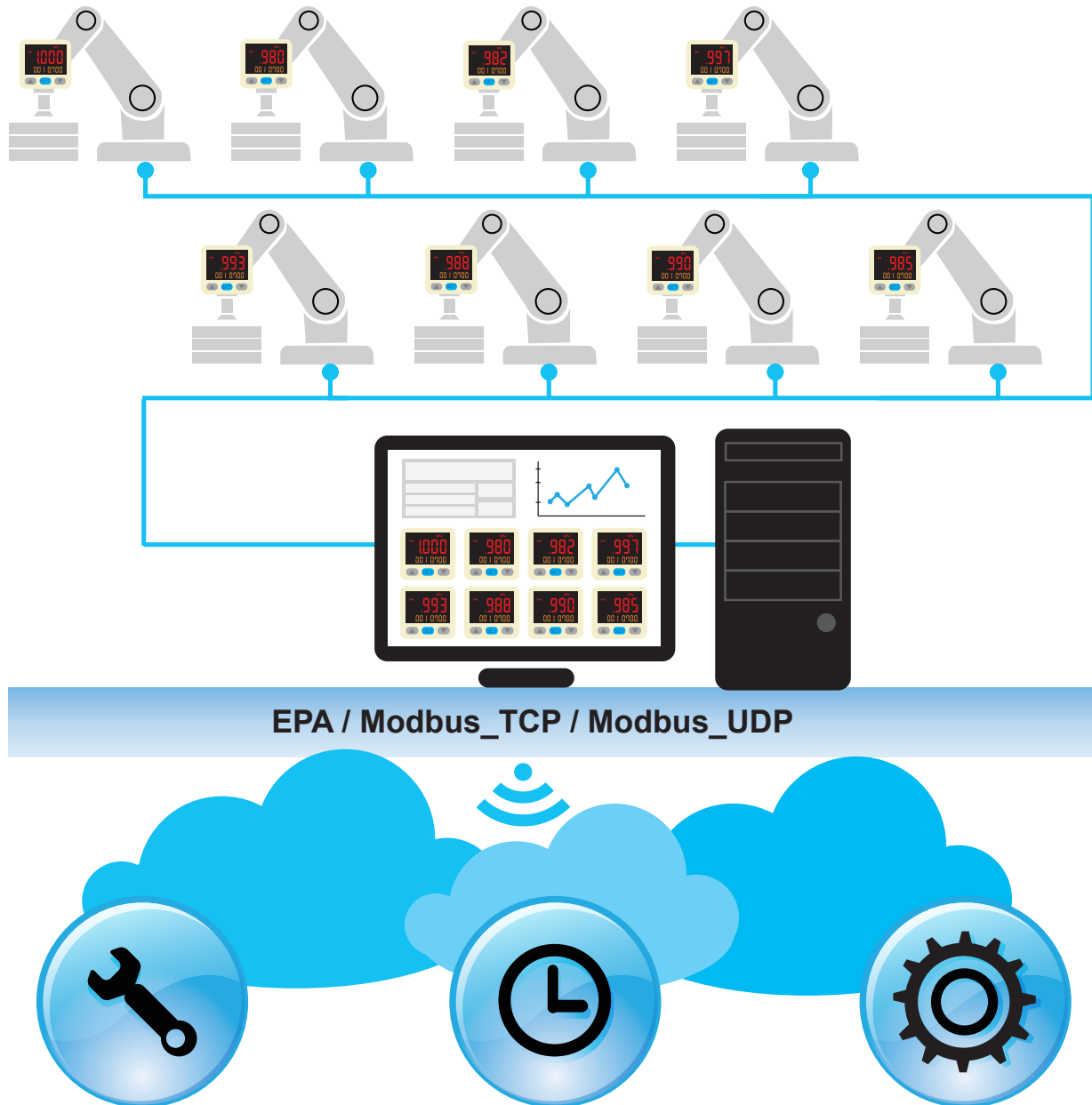

EPA / Modbus_TCP / Modbus_UDP

Prevent Damage

Early warning to prevent goods fall from robot or machine halt before suction cup break.

Remote Control

Pressure sensor does not need to be set individually, reduce fabricator setting time dramatically.

Maintain in Time

Monitoring in time and data analysis, leakage, energy waste will be nowhere to hide.

KP10 SERIES

Compact Pressure Sensor
- Switch Output

Features

- Simple installation, plug-in port or thread-in fitting
- Set pressure range :
 - 3-wire type : Vacuum (0 ~ -101.3 kPa)
 - Positive (0 ~ 0.6 MPa)
 - 2-wire type : Normally Open /
 - Normally Close (- 0.1 ~ 0.6 MPa)

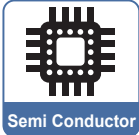
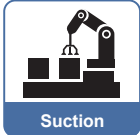

Features Highlight

1 Simple Installation

- Plug-in port for push-to-connect fittings



2 Compact Size

- Extremely compact size 26 (L) × 10 (W) × 10.4 (H) mm to fit the most confined areas

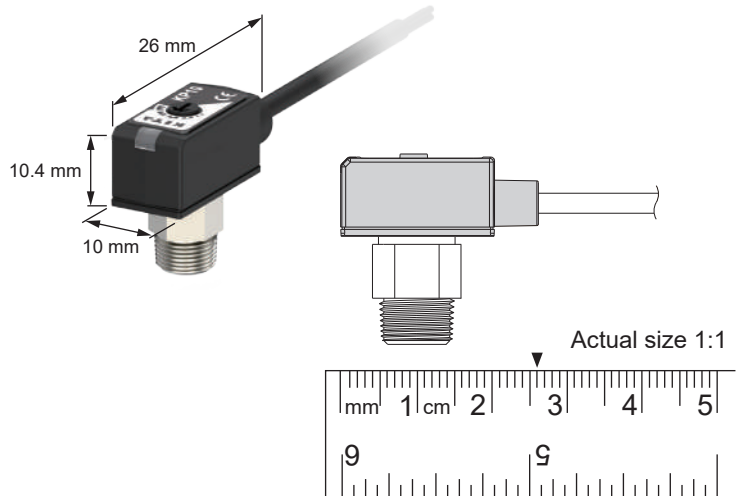

3 Space-Saving

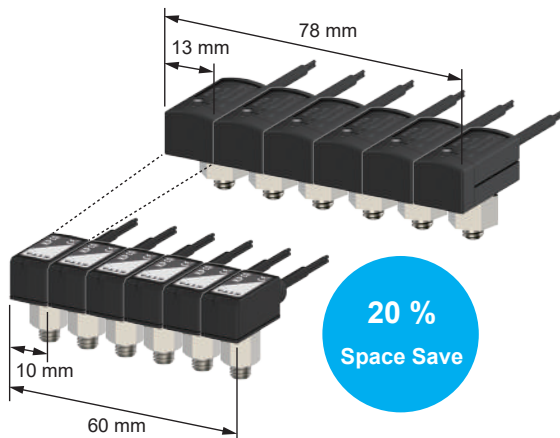

4 Sensor Installed Close to Pad



Specifications

MODEL	KP10A	KP10B	KP10V-02/04	KP10P-02/04
Set Pressure Range	- 0.1 ~ 0.6 MPa		0 ~ - 101.3 kPa	0 ~ 0.6 MPa
Withstand Pressure	1.5 MPa		0.6 MPa	1.5 MPa
Fluid	Air, Non-corrosive / Non-flammable gas			
Power Supply Voltage	12 ~ 24 V DC \pm 10 %, Ripple (P-P) \leq 10 %		10.8 ~ 30 V DC (Include ripple voltage)	
Load Current	5 ~ 40 mA		\leq 80 mA	
Current Consumption	-		\leq 10 mA	
Internal Voltage Drop	\leq 5 V		NPN \leq 0.8 V, PNP \leq 0.8 V	
Leak Current	\leq 1 mA		-	
Switch Output	Present Press. \geq Set Press. : ON	Present Press. \geq Set Press. : OFF	NPN or PNP	
Output Short Circuit Protection	No		Yes	
Setting Method	Adjusting by VR			
Repeatability	\pm 1 % F.S.			
Hysteresis	\leq 4 % F.S.		\leq 3 % F.S.	
Response Time	Approx. 1 ms			
Switch on Indicator	Indicator Red : ON			
Environment	Enclosure	IP40		
	Ambient Temp. Range	Operation : 0 ~ 60 °C (32 ~ 140 °F), Storage : -20 ~ 70 °C (-4 ~ 158 °F) (No condensation or freezing)		
	Ambient Humidity Range	Operation / Storage : 35 ~ 85 % RH (No condensation)		
	Vibration	Total amplitude 1.5 mm or 10 G, 10 Hz ~ 55 Hz ~ 10 Hz scan for 1 minute, 2 hours each direction of X, Y and Z		
	Shock	980 m/s ² (100 G), 3 times each in direction of X, Y and Z		
Temperature Characteristic	\pm 3 % F.S. of detected pressure (25 °C) at temp. (Range of 0 ~ 50 °C)			
Piping Size	R4 : \varnothing 4 mm ; R6 : \varnothing 6 mm ; F1 : R1/8", M5 ; F2 : NPT1/8", M5 ; F3 : G1/8" (BSPP), M5 ; M5 : M5 * 0.8			
Lead Wire	\varnothing 2.6 Oil-resistance cable (PVC) - 24 AWG (0.22 mm ²) - 2 cores		\varnothing 2.6 Oil-resistance cable (PVC) - 26 AWG (0.15 mm ²) - 3 cores	
Weight (with 3 meter lead wire)	Approx. 50 g			

Circuit Wiring Diagram

KP10A & KP10B

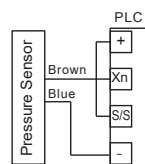
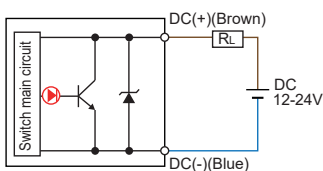

Connection to NPN input module

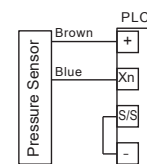
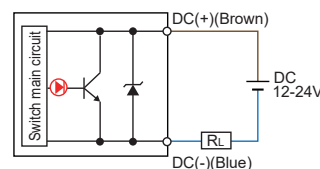

Connection to PNP input module

KP10□ - 02 - □ - □

NPN Output

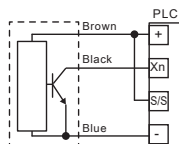
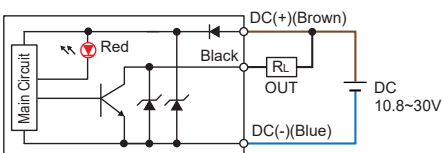

KP10□ - 04 - □ - □

PNP Output

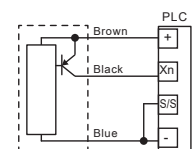
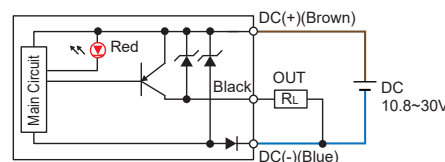

KP10 SERIES

Compact Pressure Sensor - Switch Output

Output Type

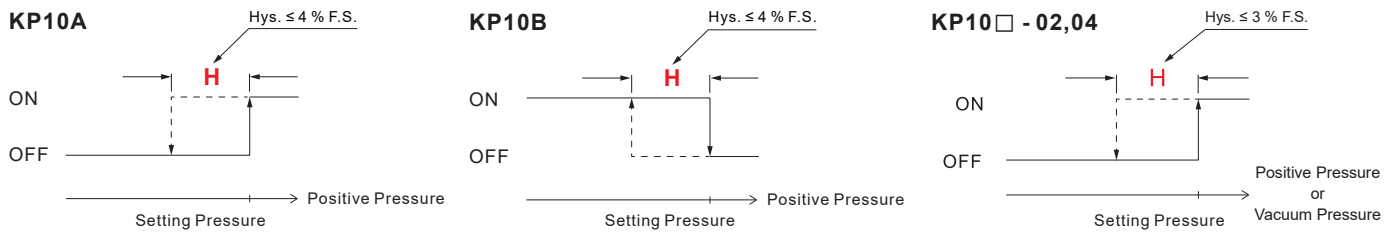

Ordering Information

K P 1 0 A - R 4 - []

Switch Specifications

- A : Switch turns ON when the pressure is larger than setting pressure. (Normally Open)
- B : Switch turns OFF when the pressure is larger than setting pressure. (Normally Close)

K P 1 0 V - 0 2 - R 4 - []

Pressure Range

- V : Vacuum (0 ~ -101.3 kPa)
- P : Positive (0 ~ 0.6 MPa)

Output Specification

- 02 : NPN output
- 04 : PNP output

Cable Length / Connector

- Blank : With 3 meter cable
- C : With M8, 3Pin male connector

Pressure Port	R4	R6	F1 / F2 / F3	M5
Appearance				
Port size	R4 : Ø4 mm	R6 : Ø6 mm	F1 : R1/8", M5 F2 : NPT1/8", M5 F3 : G1/8" (BSPP), M5	M5 : M5 * 0.8

How to Set Pressure

- Use the pressure setting trimmer to set "ON" pressure. Rotate clockwise to increase pressure setpoint. Rotate counter-clockwise to decrease pressure setpoint.
- Use appropriate size screwdriver for the setting trimmers. Gently turn the screwdriver to make adjustments. To prevent damage to the pressure setting trimmer, DO NOT force the trimmer when it comes to a stop.

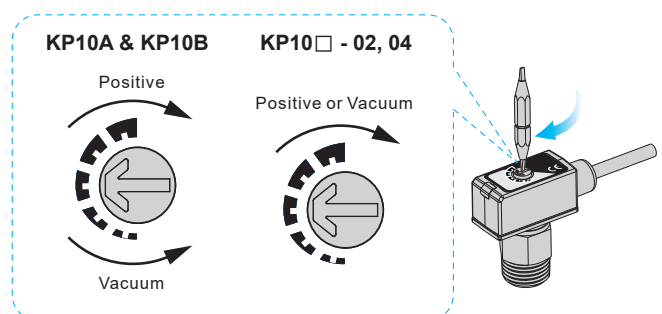

Installation Precautions

- When mounting, always use the wrench on the metallic area near the pressure port. Never apply a wrench to the plastic body, it will damage the sensor.
- Over tightening may cause damage to the port thread, mounting bracket and pressure sensor. Under tightening may result loosen or leakage.
- Apply air pressure and power after installation, make necessary adjustments and inspect any possible signs of leakage to ensure proper installation.

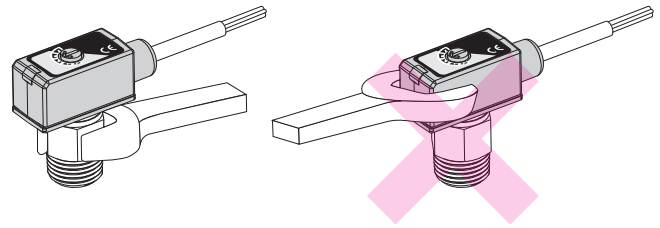

Dimensions

KP10□ - 02, 04 - □ - C

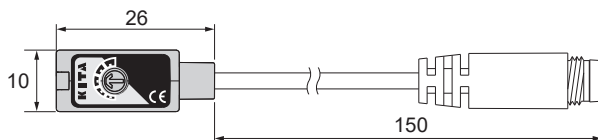

QD PINOUT

KP10A - □ - C \ KP10B - □ - C

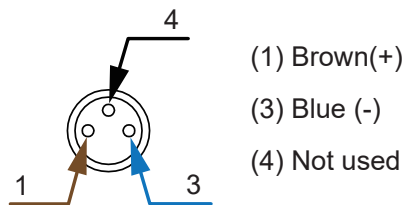

QD PINOUT

KP10□ - 02, 04 - □ - C

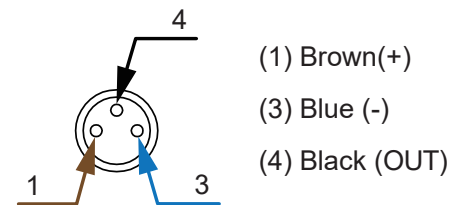

KP10□ - 02, 04 - F1, F2, F3

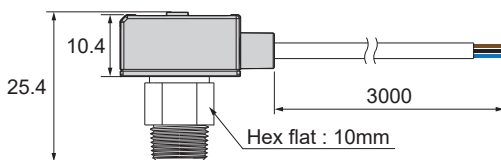

KP10□ - 02, 04 - R6

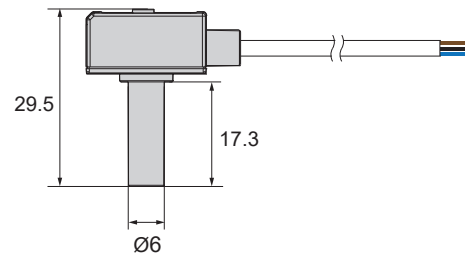

KP10□ - 02, 04 - M5

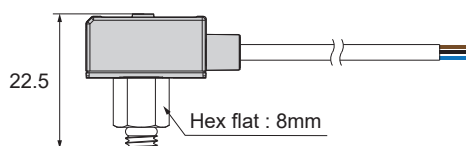

KP10□ - 02, 04 - R4

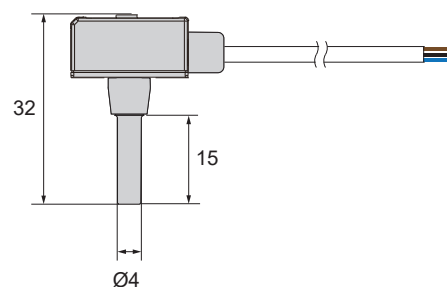

Unit : mm

KP10 SERIES

Compact Pressure Sensor
- Analog Output

Features

- Simple installation, plug-in port or thread-in fitting
- Compact size : 26 × 10 × 10.4 mm
- Rated pressure range :
 - Compound (-100 ~ 100 kPa)
 - Compound (-101 ~ 500 kPa)
 - Low (0 ~ 100 kPa)
 - Vacuum (0 ~ -101.3 kPa)
 - Positive (0 ~ 1.0 MPa)
 - Micro pressure S1 (0 ~ 10 kPa)
 - Micro pressure S2 (0 ~ 5 kPa)

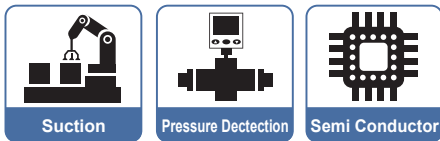

Specifications

MODEL	KP10S1	KP10S2	KP10C-01	KP10L-01	KP10V-01	KP10R-01	KP10P-01
Rated Pressure Range	0 ~ 10 kPa	0 ~ 5 kPa	-100 ~ 100 kPa	0 ~ 100 kPa	0 ~ -101.3 kPa	-101 ~ 500 kPa	0 ~ 1.0 MPa
Withstand Pressure	20 kPa		0.2 MPa			1.5 MPa	
Fluid	Filtered air, Non-corrosive / Non-flammable gas						
Power Supply Voltage	12 ~ 24 V DC (5 % ripple voltage)						
Current Consumption	≤ 15 mA			≤ 10 mA			
Analog Output	1 ~ 5 V ± 1 % F.S. / Linearity ± 0.5 % F.S.		1 ~ 5 V ± 1 % F.S. / Linearity ± 0.5 % F.S.				
Environment	Enclosure	IP40					
	Ambient Temp. Range	Operation : 0 ~ 50 °C (32 ~ 122 °F), Storage : -20 ~ 70 °C (-4 ~ 158 °F) (No condensation or freezing)					
	Ambient Humidity Range	Operation / Storage : 35 ~ 85% RH (No condensation)					
	Vibration	Total amplitude 1.5 mm or 10 G, 10 Hz ~ 55 Hz ~ 10 Hz scan for 1 minute, 2 hours each direction of X, Y and Z					
Shock	980 m/s ² (100 G), 3 times each in direction of X, Y and Z						
Temperature Characteristic	± 3 % F.S. of detected pressure (25 °C) at temp. (Range of 0 ~ 50 °C)		± 2 % F.S. of detected pressure (25 °C) at temp. (Range of 0 ~ 50 °C)				
Piping Size	R4 : Ø4 mm ; R6 : Ø6 mm ; F1 : R1/8", M5 ; F2 : NPT1/8", M5 ; F3 : G1/8" (BSPP) , M5 ; M5 : M5 * 0.8						
Lead Wire	Ø2.6 Oil-resistance cable (PVC) - 26 AWG (0.15 mm ²) - 3 cores						
Weight (with 3 meter lead wire)	Approx. 50 g						

Circuit Wiring Diagrams

KP10S□ - 01 - □ - □
Analog Output (1 ~ 5 V)

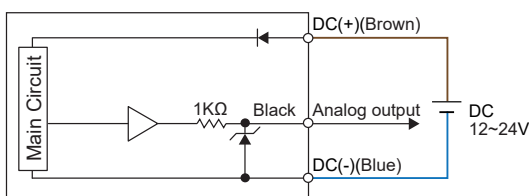

KP10□ - 01 - □ - □
Analog Output (1 ~ 5 V)

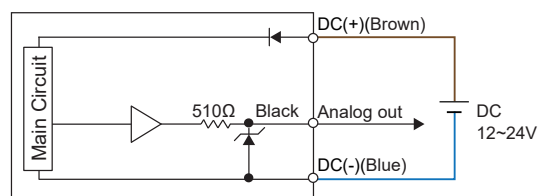

Output Type

KP10S□ - 01 - □ - □

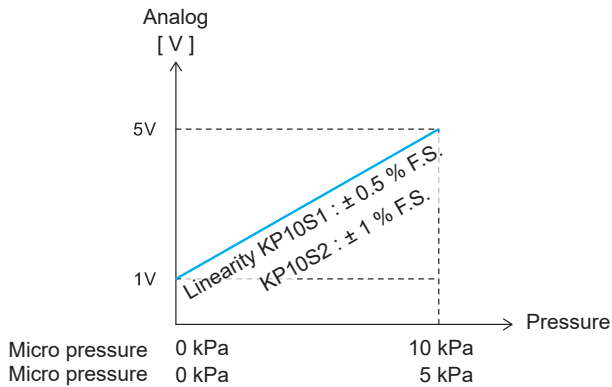

KP10□ - 01 - □ - □

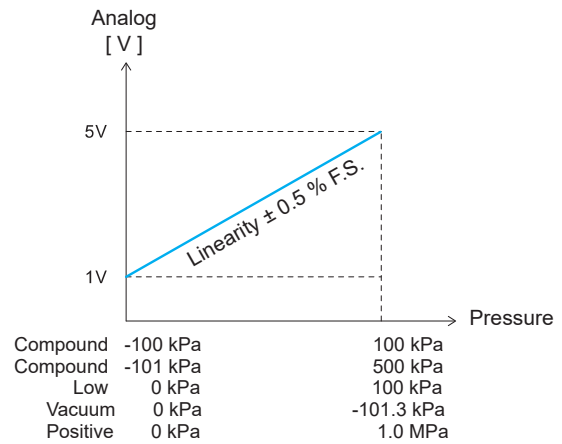

Ordering Information

K P 1 0 V - 0 1 - R 4 - □

Pressure Range

C : Compound (-100 ~ 100 kPa) P : Positive (0 ~ 1.0 MPa)
R : Compound (-101 ~ 500 kPa) S1 : Micro pressure (0 ~ 10 kPa)
L : Low (0 ~ 100 kPa) S2 : Micro pressure (0 ~ 5 kPa)
V : Vacuum (0 ~ -101.3 kPa)

Output Specification

01 : Analog output (1 ~ 5 V)

Cable Length / Connector

Blank : With 3 meter cable
C : With M8 3Pin male connector

Pressure Port

R4 : Ø4 mm F2 : NPT1/8", M5
R6 : Ø6 mm F3 : G1/8" (BSPP), M5
F1 : R1/8", M5 M5 : M5 * 0.8

Dimensions

KP10□ - 01 - □ - C

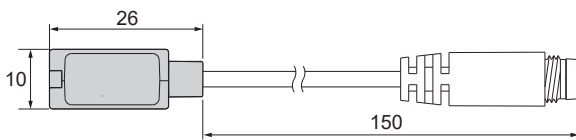

QD PINOUT

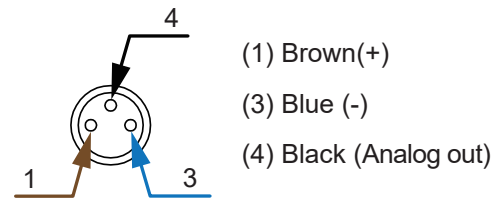

KP10□ - 01 - R4

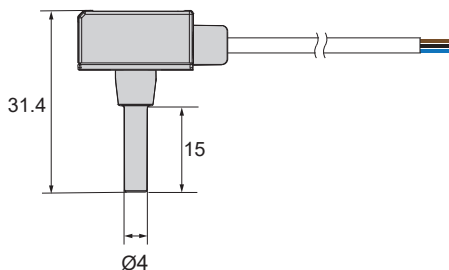

KP10□ - 01 - F1, F2, F3

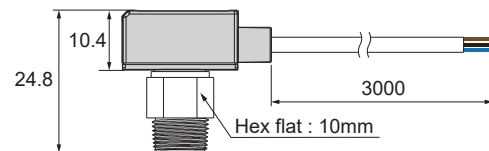

KP10□ - 01 - R6

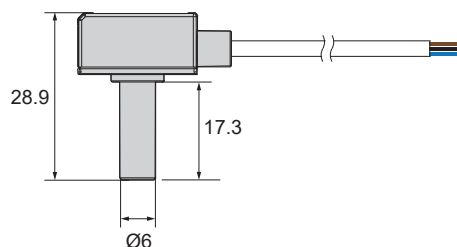

KP10□ - 01 - M5

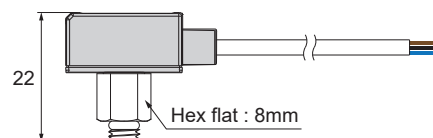

Unit : mm

KP101 KP102

SERIES

Compact Pressure Sensor

Features

- Simple installation, plug-in port or thread-in fitting
- Set pressure range : -0.1 ~ 0.4 MPa
- Normally Open / Normally Close

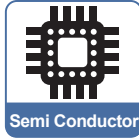
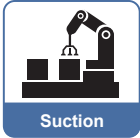

Features Highlight

1 Simple Installation

- Plug-in port for push-to-connect fittings

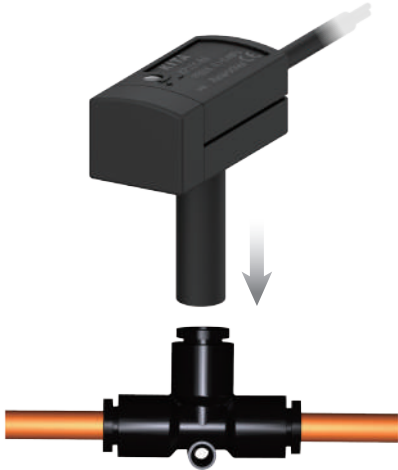

2 Compact Size

- Extremely compact size 30(L) × 13(W) × 11.5(H) mm to fit the most confined areas

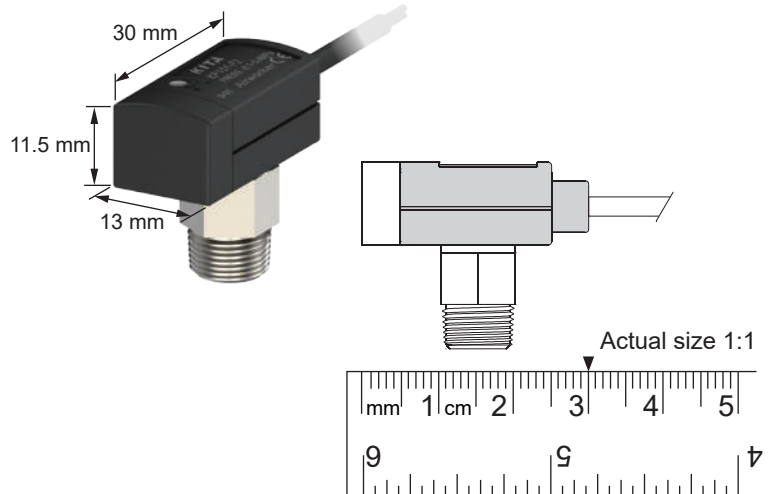

Specifications

MODEL		KP101	KP102
	0.4 MPa 0 -0.1 MPa		
Set Pressure Range		- 0.1 ~ 0.4 MPa	
Withstand Pressure		1 MPa	
Fluid		Filtered air, Non-corrosive / Non-flammable gas	
Power Supply Voltage		12 ~ 24 V DC ± 10 %, Ripple (P-P) ≤ 10 %	
Load Current		5 ~ 40 mA	
Leak Current		≤ 1 mA	
Internal Voltage Drop		≤ 5 V	
Switch Output		Present Press. ≥ Set Press. : ON	Present Press. ≥ Set Press. : OFF
Response Time		Approx. 1 ms	
Repeatability		± 1 % F.S.	
Hysteresis		≤ 4 % F.S.	
Switch on Indicator		Indicator Red : ON	
Environment	Enclosure	IP40	
	Ambient Temp. Range	Operation : 0 ~ 60 °C (No condensation or freezing)	
Temperature Characteristic		± 3 % F.S. of detected pressure (25 °C) at temp. (Range of 0 ~ 50 °C)	
Piping Size		R6 : Ø6 mm ; F1 : R1/8" , M5 ; F2 : NPT1/8" , M5 ; F3 : G1/8" (BSPP) , M5 ; M5 : M5 * 0.8	
Lead Wire		Ø2.6 Oil-resistance cable (PVC) - 24 AWG (0.22 mm ²) - 2 cores	
Weight (with 2 meter lead wire)		Approx. 38 g	

Circuit Wiring Diagram

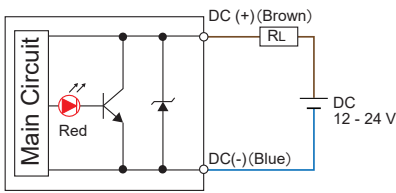

Output Type

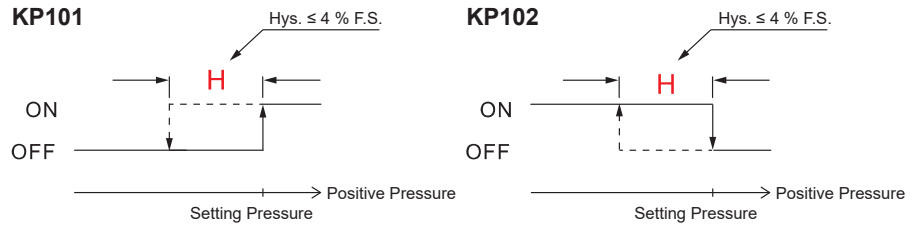

Ordering Information

K P 1 0 1 - F 1 - []

Sensor Specification

- 101 : Switch turns ON when the pressure is larger than setting pressure.
- 102 : Switch turns OFF when the pressure is larger than setting pressure.

Pressure Port

- R6 : Ø6 mm
- F3 : G1/8" (BSPP), M5
- F1 : R1/8", M5
- M5 : M5 * 0.8
- F2 : NPT1/8", M5

Cable Length / Connector

- Blank : With 2 meter cable
- C : With M8 3Pin male connector

How to Set Pressure

- Use the pressure setting trimmer to set "ON" pressure. Rotate clockwise to increase pressure setpoint (or to decrease vacuum setpoint). Rotate counter-clockwise to decrease pressure setpoint (or to increase vacuum setpoint).
- Use appropriate size screwdriver for the setting trimmers. Gently turn the screwdriver to make adjustments. To prevent damage to the pressure setting trimmer, DO NOT force the trimmer when it comes to a stop.

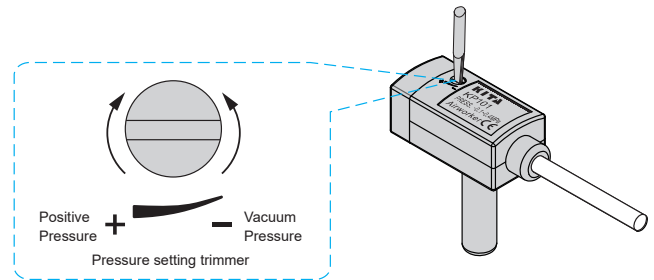

Installation Precautions

- When mounting, always use the wrench on the metallic area near the pressure port. Never apply a wrench to the plastic body, it will damage the sensor.
- Over tightening may cause damage to the port thread, mounting bracket and pressure sensor. Under tightening may result loosen or leakage.
- Apply air pressure and power after installation, make necessary adjustments and inspect any possible signs of leakage to ensure proper installation.

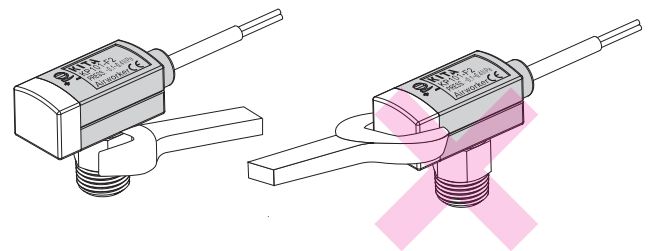

Dimensions

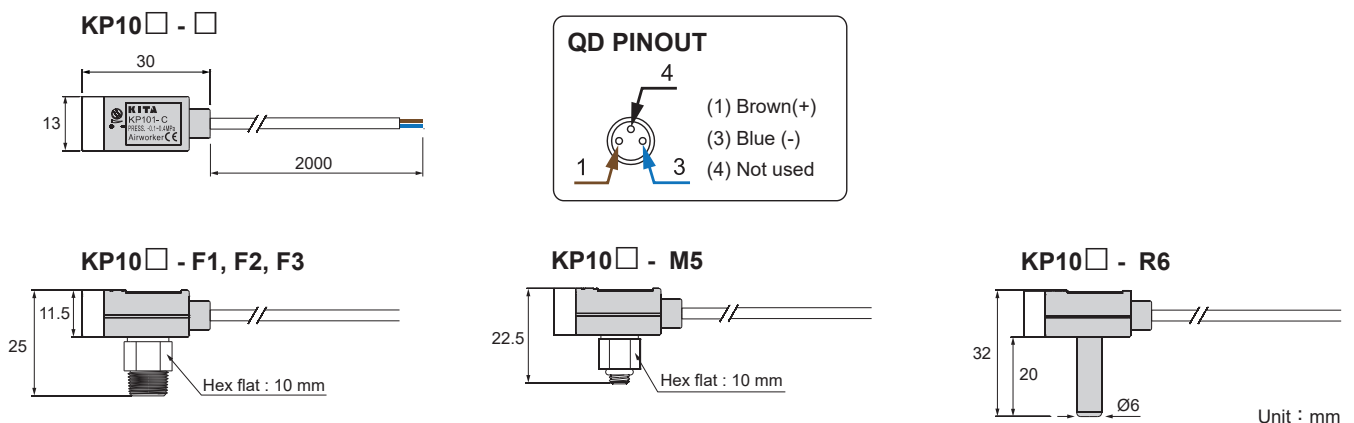

Unit : mm

Features

- 1 output (hysteresis adjustable)
- 2 outputs
- Easy installation
- Response time : less than 5 ms

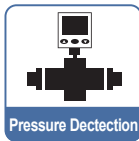
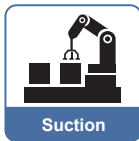

Features Highlight

1 Hysteresis Adjustable

- Output hysteresis (H) is adjustable

KP1- □ - 01, 02

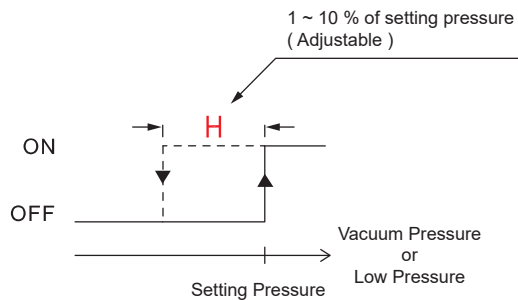

KP1 - □ - 03

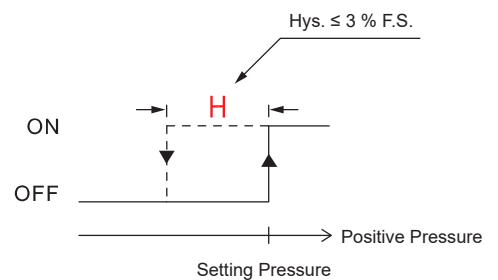

Installation Precautions

- When mounting, always use the wrench on the metallic area near the pressure port. Never apply a wrench to the plastic body, it will damage the sensor.
- Over tightening may cause damage to the port thread, mounting bracket and pressure sensor. Under tightening may result loosen or leakage.
- Apply air pressure and power after installation, make necessary adjustments and inspect any possible signs of leakage to ensure proper installation.

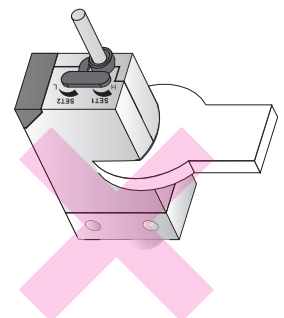
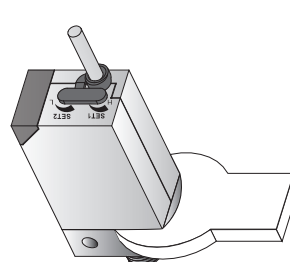

Specifications

MODEL	KP1-1	KP1-2	KP1-3
	Vacuum	Low	Positive
Set Pressure Range	-101 ~ 0 kPa	0 ~ 100 kPa	0 ~ 1 MPa
Withstand Pressure	300 kPa		1.5 MPa
Fluid	Filtered air, Non-corrosive / Non-flammable gas		
Power Supply Voltage	12 ~ 24 V DC \pm 10 %, Ripple (P-P) \leq 10 %		
Current Consumption	1 NPN or 1 PNP output : \leq 21 mA ; 2 NPN output : \leq 35 mA		
Repeatability	\pm 1 % F.S.		
Response Time	\leq 5 ms		
Environment	Enclosure	IP40	
	Ambient Temp. Range	Operation : 0 ~ 50 °C, storage : -20 ~ 60 °C (No condensation or freezing)	
	Ambient Humidity Range	Operation / Storage : 35 ~ 85 % RH (No condensation)	
	Withstand Voltage	1000 V AC in 1-min (between case and lead wire)	
	Insulation Resistance	\geq 50 M Ω (at 500 V DC, between case and lead wire)	
	Vibration	Total amplitude 1.5 mm or 10 G, 10 Hz ~ 55 Hz ~ 10 Hz scan for 1 minute, 2 hours each direction of X, Y and Z	
Shock	980 m/s ² (100 G), 3 times each in direction of X, Y and Z		
Temperature Characteristic	\pm 3 % F.S. of detected pressure (25 °C) at temp. (Range of 0 ~ 50 °C)		
Port Size	PT : 1/8"PT (R1/8"), M5 ; NPT : NPT1/8", M5 ; G : G1/8" (BSPP), M5		
Lead Wire	\varnothing 4 Oil-resistance cable (PVC) - 24 AWG (0.22 mm ²) - 3 cores		
Weight (with 1 meter lead wire)	Approx. 50 g		

Circuit Wiring Diagrams

MODEL	KP1 - □ - 01	KP1 - □ - 02	KP1 - □ - 03
Connect Diagram			
Characteristics			
Output Method	NPN open collector 30 V 80 mA	PNP open collector 80 mA	NPN open collector 30 V 80 mA
Hysteresis	1 ~ 10 % of setting pressure (Adjustable)		\leq 3 % F.S. (Fixed)
Setting Points	1 Point		2 Points
Operation Indicating Lamp	Red LED turns on		Out1 = Red, Out2 = Green

Ordering Information

K P 1 - 1 - 0 1 - 0 1 - N P T

Pressure Range

- 1 : Vacuum (-101 ~ 0 kPa)
- 2 : Low (0 ~ 100 kPa)
- 3 : Positive (0 ~ 1 MPa)

Pressure Port

- PT : 1/8"PT (R1/8"), M5
- NPT : NPT1/8", M5
- G : G1/8" (BSPP), M5

Output Specification

- 01 : NPN output
- 02 : PNP output
- 03 : 2 NPN output

Cable Length / Connector

- 01 : With 1 meter cable
- 03 : With 3 meter cable
- C : With M8 4Pin male connector

How To Set Pressure

1 KP1 - □ - 01, 02

- Remove dust cover to make adjustments to pressure value. Replace dust cover when finished to prevent foreign object from entering.
- Pressure setting trimmer (SET) is for setting the output (ON) pressure. Rotate SET trimmer counter-clockwise to increase (Pressure or Vacuum) the setting pressure (ON) point. Rotate clockwise to decrease the setting pressure.
- Hysteresis setting trimmer (HYS) is for changing the hysteresis. Rotate trimmer counter-clockwise to increase the range 1 ~ 10 %.
- Use appropriate size screwdriver for the setting trimmers. Gently turn the screwdriver to make adjustments. Do not force the trimmer when it comes to a stop to prevent damage to the setting trimmer.

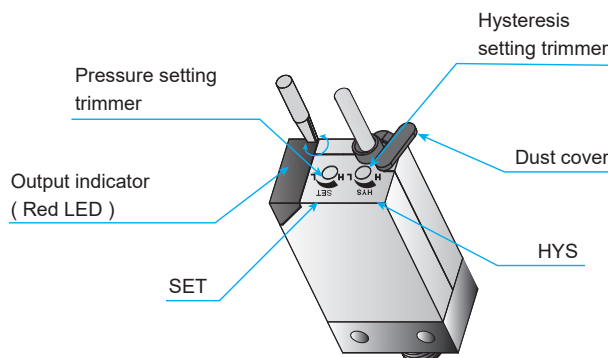

2 KP1 - □ - 03

- Remove dust cover to make any adjustments. Replace dust cover when finished to prevent foreign object from entering.
- Pressure setting trimmer (SET 1, SET 2) is for setting the output (ON) pressure. Rotate SET trimmer counter-clockwise to increase (Pressure or Vacuum) the ON point. Rotate clockwise will decrease the setting pressure.
- Hysteresis for models with two outputs is 3 % fixed.

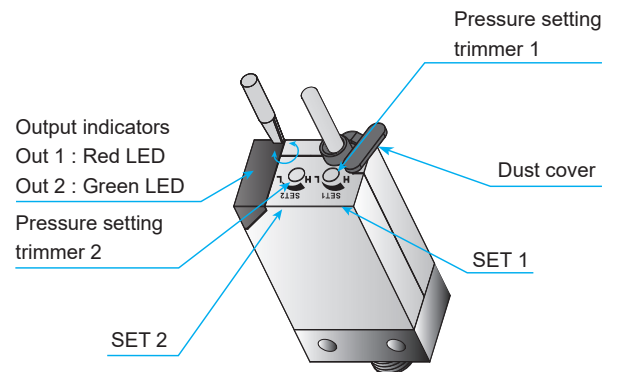

Dimensions

KP1 - □ - □ - □

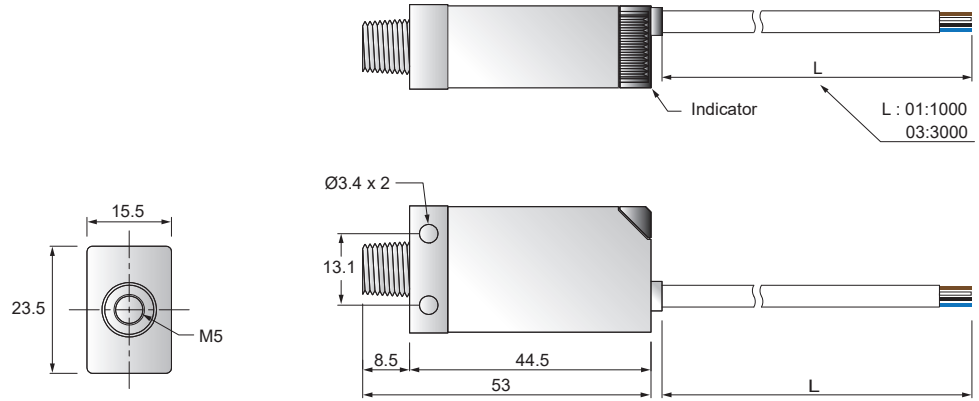

KP1 - □ - C - □

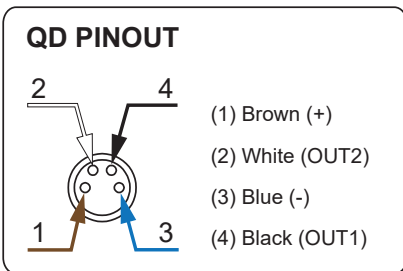
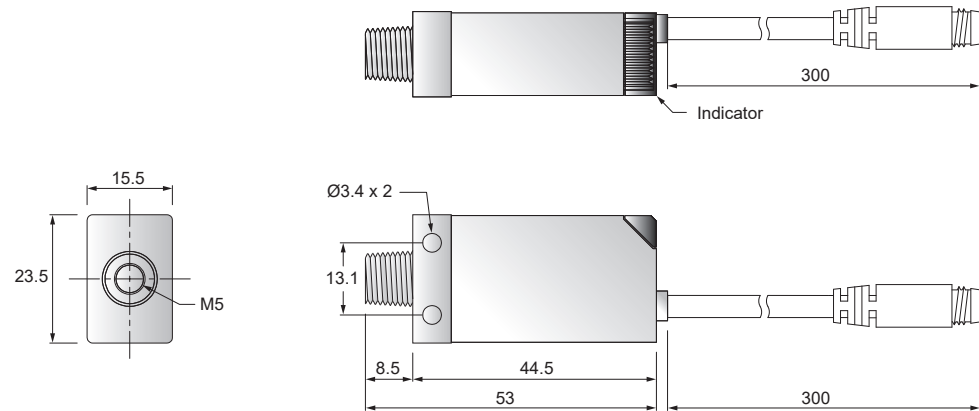

Unit : mm

KP30 SERIES

Features

- Set pressure range :
Compound (-100.0 ~ 100.0 kPa)
Vacuum (10.0 ~ -101.3 kPa)
Positive (-0.100 ~ 1.000 MPa)
- 2 outputs & analog output (1 ~ 5 V)
- Hysteresis adjustable
- Programmable pressure unit :
kPa 、 MPa 、 kgf / cm² 、 bar 、 psi 、 inHg 、 mmHg 、 mmH₂O

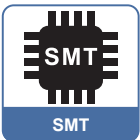
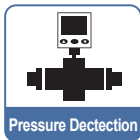
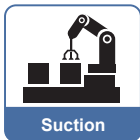

Features Highlight

1 Programmable Pressure Unit

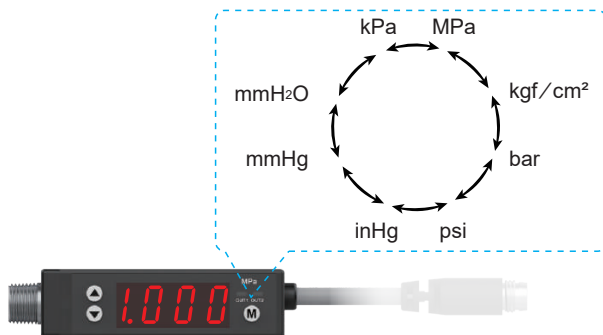

2 Key Lock Function

- Key lock mode to prevent unauthorized adjustments
Press **M** more than 5 seconds to enter key lock mode
Use **▲** or **▼** to select key lock status

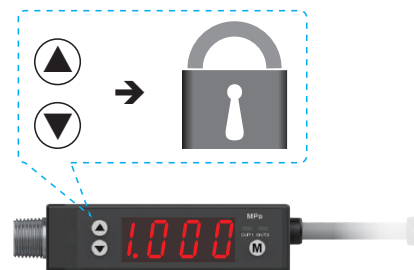

3 Analog Output

- 2 outputs & analog output (1 ~ 5 V)
Output range 1 to 5 V, proportional to the pressure range

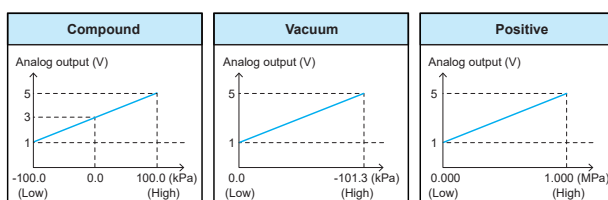

4 Hysteresis adjustable

- Output hysteresis (**H**) is adjustable

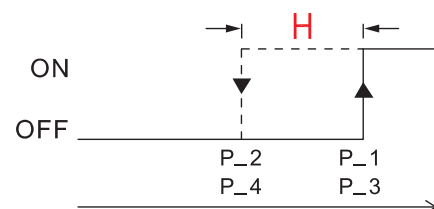

Specifications

MODEL		KP30C	KP30V	KP30P
		Compound	Vacuum	Positive
Rated Pressure Range		-100.0 ~ 100.0 kPa	0.0 ~ -101.3 kPa	0.000 ~ 1.000 MPa
Set Pressure Range		-100.0 ~ 100.0 kPa	10.0 ~ -101.3 kPa	-0.100 ~ 1.000 MPa
Withstand Pressure		300 kPa		1.5 MPa
Fluid		Filtered air, Non-corrosive / Non-flammable gas		
Set Pressure Resolution	kPa	0.1		-
	MPa	-		0.001
	kgf / cm ²	0.001		0.01
	bar	0.001		0.01
	psi	0.01		0.1
	inHg	0.1		-
	mmHg	1		-
	mmH ₂ O	0.1		-
Power Supply Voltage		12 ~ 24 V DC ± 10 %, Ripple (P-P) ≤ 10 %		
Current Consumption		≤ 60 mA		
Switch Output		2 NPN : open collector 2 outputs Max. Load Current : 100 mA Max. Supply Voltage : 30 V DC Residual Voltage : ≤ 1 V	2 PNP : open collector 2 outputs Max. Load Current : 100 mA Max. Supply Voltage : 24 V DC Residual Voltage : ≤ 1 V	
Repeatability		± 0.2 % F.S. ± 1 digit		
Hysteresis	Hysteresis Mode	Adjustable		
	Window Comparator Mode	Fixed (3 digits)		
Response Time		≤ 2.5 ms (Chattering-proof function : 24 ms, 192 ms and 768 ms selectable)		
Output Short Circuit Protection		Yes		
Display		3 ½ digit, 7 segment LED display (Red) (Sampling rate : 5 times / sec.)		
Indicator Accuracy		± 2 % F.S. ± 1 digit (Ambient temperature : 25 ± 3 °C)		
Switch on Indicator		Indicator Green : OUT1 & Indicator Red : OUT2		
Analog Output (Only Type KP30 □ - 01 - □ , KP30 □ - 03 - □)		Output Voltage : 1 ~ 5 V ± 5 % F.S. (within rated pressure range) Linearity : ± 1 % F.S.	Output Voltage : 1 ~ 5 V ± 2.5 % F.S. (within rated pressure range) Linearity : ± 1 % F.S.	
Environment	Enclosure	IP40		
	Ambient Temp. Range	Operation : 0 ~ 50 °C, storage : -20 ~ 60 °C (No condensation or freezing)		
	Ambient Humidity Range	Operation / Storage : 35 ~ 85 % RH (No condensation)		
	Withstand Voltage	1000 V AC in 1-min (between case and lead wire)		
	Insulation Resistance	≥ 50 MΩ (at 500 V DC, between case and lead wire)		
	Vibration	Total amplitude 1.5 mm or 10 G, 10 Hz ~ 55 Hz ~ 10 Hz scan for 1 minute, 2 hours each direction of X, Y and Z		
	Shock	980 m/s ² (100 G), 3 times each in direction of X, Y and Z		
Temperature Characteristic		± 2 % F.S. of detected pressure (25 °C) at temp. (Range of 0 ~ 50 °C)		
Port Size		F1 : R1/8", M5 ; F2 : NPT1/8", M5 ; F3 : G1/8" (BSPP), M5		
Lead Wire		Ø4 Oil-resistance cable (PVC) - 26 AWG (0.15 mm ²) - 5 cores (KP30 □ - 01 / 03) ; Ø4 Oil-resistance cable (PVC) - 26 AWG (0.15 mm ²) - 4 cores (KP30 □ - 02 / 04)		
Weight		Approx. 67 g (with 2 meter lead wire) ; Approx. 40 g (with M8 4Pin male connector)		

KP30 SERIES

Panel Description

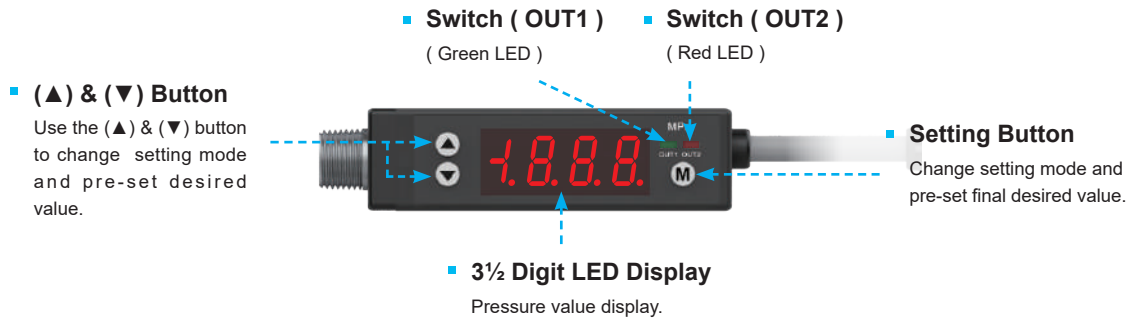

Circuit Wiring Diagrams

KP30 □ - 01 - □ - □

NPN Output & Analog Output (1 ~ 5 V)

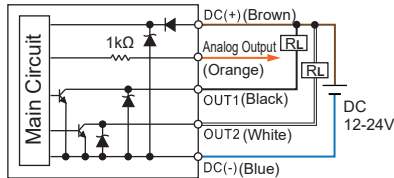

KP30 □ - 02 - □ - □

NPN Output

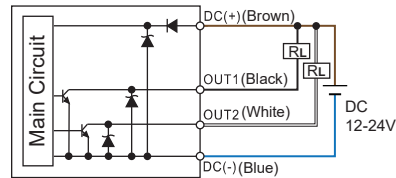

KP30 □ - 03 - □ - □

PNP Output & Analog Output (1 ~ 5 V)

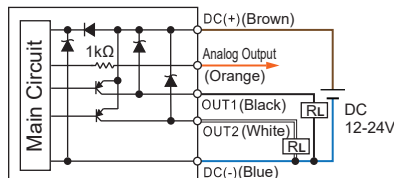

KP30 □ - 04 - □ - □

PNP Output

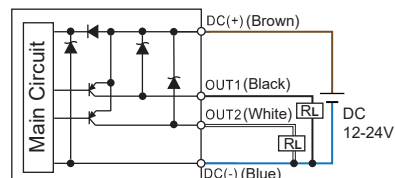

Ordering Information

K P 3 0 C - 01 - F1 -

Pressure Range

C : Compound (-100.0 ~ 100.0 kPa)
 V : Vacuum (10.0 ~ -101.3 kPa)
 P : Positive (-0.100 ~ 1.000 MPa)

Pressure Port

F1 : R1/8", M5
 F2 : NPT1/8", M5
 F3 : G1/8" (BSPP), M5

Output Specification

01 : 2 NPN output & Analog output (1 ~ 5 V)
 02 : 2 NPN output
 03 : 2 PNP output & Analog output (1 ~ 5 V)
 04 : 2 PNP output

Cable Length / Connector

Blank : With 2 meter cable
 QD : With M8 4Pin male connector
 * (Only type KP30 □ - 02 - □ , KP30 □ - 04 - □)

Installation Precautions

- When mounting, always use the wrench on the metallic area near the pressure port. Never apply a wrench to the plastic body, it will damage the sensor.
- Over tightening may cause damage to the port thread, mounting bracket and pressure sensor. Under tightening may result loosen or leakage.
- Apply air pressure and power after installation, make necessary adjustments and inspect any possible signs of leakage to ensure proper installation.

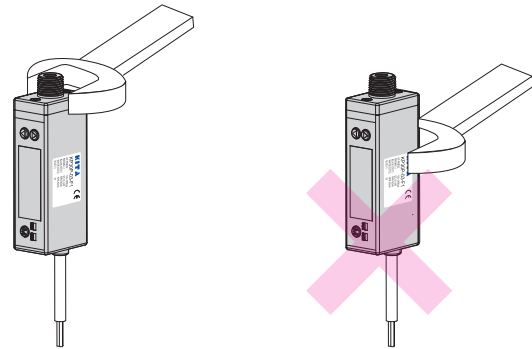

Dimensions

KP30□ - □ - □

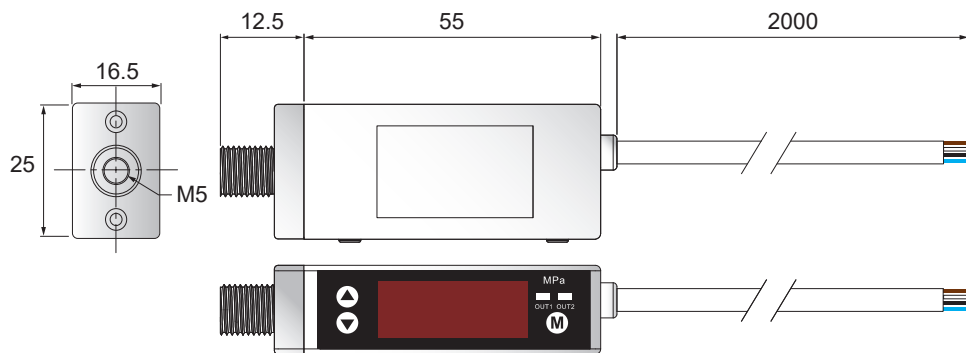

KP30□ - □ - □ - QD

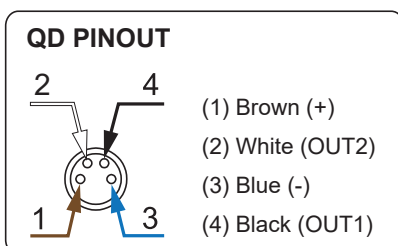
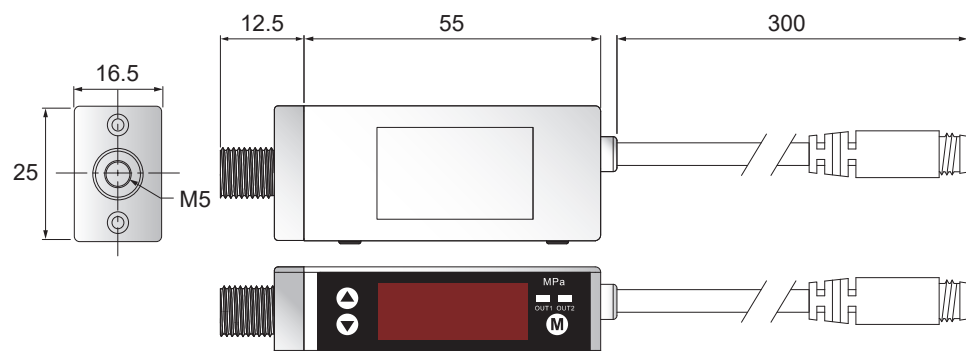

Unit : mm

Features

- 3-color digital LCD display
- Copy function
- Selectable pressure unit :
kPa、MPa、kgf/cm²、bar、psi、inHg、mmHg
- Dual LCD display allows setting value to be displayed
- Key-lock indicator
- Power-save mode

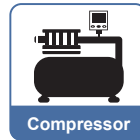
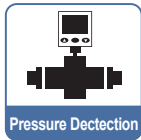
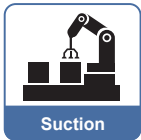

Features Highlight

1 Quick Installation

- Save Installation Time
- Easy Removal

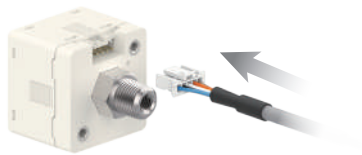

(Removable Data Cable)

2 Copy Setting

- Avoid setting errors
- Reduce setting time



(Original Parameter) (Copied)

3 Setting Value Easy Indication

- User can easily observe the setting value from sub-display

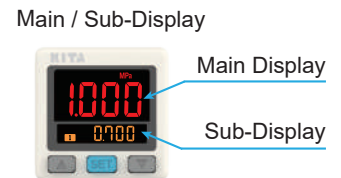

4 2-Color Main Display

- User selectable color mode, for different conditions use



	SoG	SoR	Grn	rEd
ON	Green	Red	Green	Red
OFF	Red	Green	Green	Red

5 OPS Quick Setting

- Sub-display allows changing parameter directly, reduce setting step by 3/4

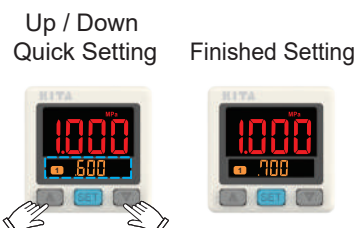

6 Easy Unit Identification

- Unit conversion easy to read



Specifications

MODEL		KP43C	KP43V	KP43P
		Compound	Vacuum	Positive
Rated Pressure Range		-100.0 ~ 100.0 kPa	0.0 ~ -101.3 kPa	0.000 ~ 1.000 MPa
Set Pressure Range		-101.0 ~ 101.0 kPa	10.0 ~ -101.3 kPa	-0.100 ~ 1.000 MPa
Withstand Pressure		300 kPa		1.5 MPa
Fluid		Filtered air, Non-corrosive / Non-flammable gas		
Set Pressure Resolution	kPa	0.1		-
	MPa	-		0.001
	kgf / cm ²	0.001		0.01
	bar	0.001		0.01
	psi	0.01		0.1
	inHg	0.1		-
	mmHg	1		-
Power Supply Voltage		12 ~ 24 V DC \pm 10 %, Ripple (P-P) \leq 10 %		
Current Consumption		\leq 40 mA (with no load)		
Switch Output		2 NPN : open collector 2 outputs Max. Load Current : 125 mA Max. Supply Voltage : 30 V DC Residual Voltage : \leq 1.5 V	2 PNP : open collector 2 outputs Max. Load Current : 125 mA Max. Supply Voltage : 24 V DC Residual Voltage : \leq 1.5 V	
Repeatability		\pm 0.2 % F.S. \pm 1 digit		
Hysteresis	One Point Set Mode	Adjustable ※1		
	Hysteresis Mode			
	Window Comparator Mode			
Response Time		\leq 2.5 ms (Chattering-proof function : 25 ms, 100 ms, 250 ms, 500 ms, 1000 ms and 1500 ms selectable)		
Output Short Circuit Protection		Yes		
Display		3 ½ digital, 7 segment LCD display (Red / Green / Orange) (Sampling rate : 5 times / sec.)		
Indicator Accuracy		\pm 2 % F.S. \pm 1 digit (Ambient temperature : 25 \pm 3 °C)		
Switch on Indicator		Orange Indicator 1 : OUT1 & Orange Indicator 2 : OUT2		
Analog Output (Voltage Output) ※2		Output Voltage : 1 ~ 5 V \pm 2.5 % F.S. (within rated pressure range) Linearity : \pm 1 % F.S. Output Impedance : about 1 k Ω		
Analog Output (Current Output) ※3		Output Current : 4 ~ 20 mA \pm 2.5 % F.S. (within rated pressure range) Linearity : \pm 1 % F.S. Max. Load Impedance : 300 Ω at power supply of 12 V 600 Ω at power supply of 24 V Min. Load Impedance : 50 Ω		
Environment	Enclosure	IP40		
	Ambient Temp. Range	Operation : 0 ~ 50 °C, Storage : -10 ~ 60 °C (No condensation or freezing)		
	Ambient Humidity Range	Operation / Storage : 35 ~ 85 % RH (No condensation)		
	Withstand Voltage	1000 V AC in 1-min (between case and lead wire)		
	Insulation Resistance	\geq 50 M Ω (at 500 V DC, between case and lead wire)		
	Vibration	Total amplitude 1.5 mm or 10 G, 10 Hz ~ 55 Hz ~ 10 Hz scan for 1 minute, 2 hours each direction of X, Y and Z		
Shock		100 m/s ² (10 G), 3 times each in direction of X, Y and Z		
Temperature characteristic		\pm 2.5 % F.S. of detected pressure (25 °C) at temp. (Range of 0 ~ 50 °C)		
Port size		F1 : R1/8", M5 ; F2 : NPT1/8", #10-32 UNF ; F3 : G1/8" (BSPP), M5		
Lead wire		\varnothing 4 Oil-resistance cable (PVC) - 26 AWG (0.15 mm ²) - 5 cores		
Weight (with 2 meter lead wire)		Approx. 80 g		

NOTE

※1 : Hysteresis value is adjustable within 1 ~ 8 digits for one point set mode and window comparator mode.

※2 : If analog voltage output is selected, the analog current output cannot be selected at the same time.

※3 : If analog current output is selected, the analog voltage output cannot be selected at the same time.

KP43 SERIES

General Pressure Sensor

Panel Description

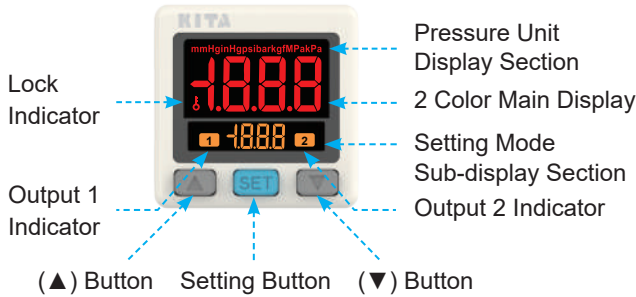

Installation Precautions

- When mounting, always use the wrench on the metallic area near the pressure port. Never apply a wrench to the plastic body, it will damage the sensor.
- Over tightening may cause damage to the port thread, mounting bracket and pressure sensor. Under tightening may result loosen or leakage.
- Apply air pressure and power after installation, make necessary adjustments and inspect any possible signs of leakage to ensure proper installation.

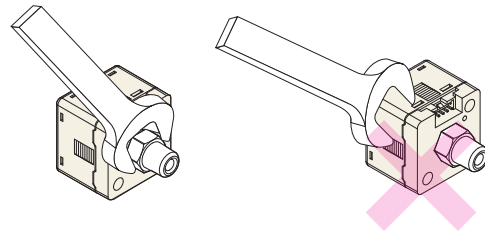

Circuit Wiring Diagrams

KP43□ - 010 - □

2NPN + Analog Output (1 ~ 5 V)

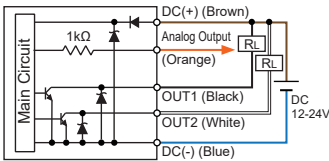

KP43□ - 011 - □

2NPN + Analog Output (4 ~ 20 mA)

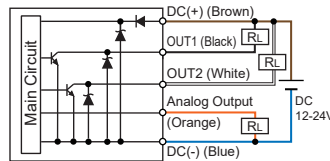

KP43□ - 02 - □

2NPN + Copy Function

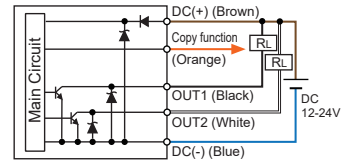

KP43□ - 030 - □

2PNP + Analog Output (1 ~ 5 V)

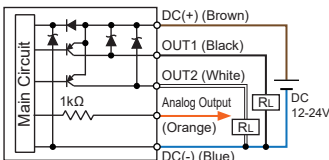

KP43□ - 031 - □

2PNP + Analog Output (4 ~ 20 mA)

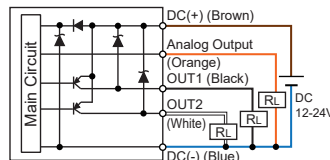

KP43□ - 04 - □

2PNP + Copy Function

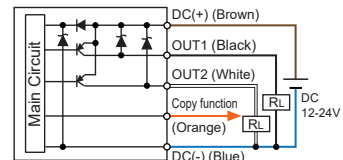

Ordering Information

K P 4 3 C - 0 1 0 - F 1

Pressure Range

C : Compound (-101.0 ~ 101.0 kPa)
 V : Vacuum (10.0 ~ -101.3 kPa)
 P : Positive (-0.100 ~ 1.000 MPa)

Output Specifications

010 : 2 NPN Output & Analog Output (1 ~ 5 V)
 011 : 2 NPN Output & Analog Output (4 ~ 20 mA)
 02 : 2 NPN Output & Copy Function
 030 : 2 PNP Output & Analog Output (1 ~ 5 V)
 031 : 2 PNP Output & Analog Output (4 ~ 20 mA)
 04 : 2 PNP Output & Copy Function

Pressure Port

F1 : R1/8", M5
 F2 : NPT1/8", #10-32UNF
 F3 : G1/8" (BSPP), M5

Optional Parts

BT-12 : Mounting bracket
 BT-13 : Mounting bracket
 PA-C : Panel adapter
 PA-D : Panel adapter +
 Front protective lid

Optional Parts

- Mounting bracket : BT-12 / BT-13



- Panel adapter : PA-C



- Panel adapter + Front protective lid : PA-D



Dimensions

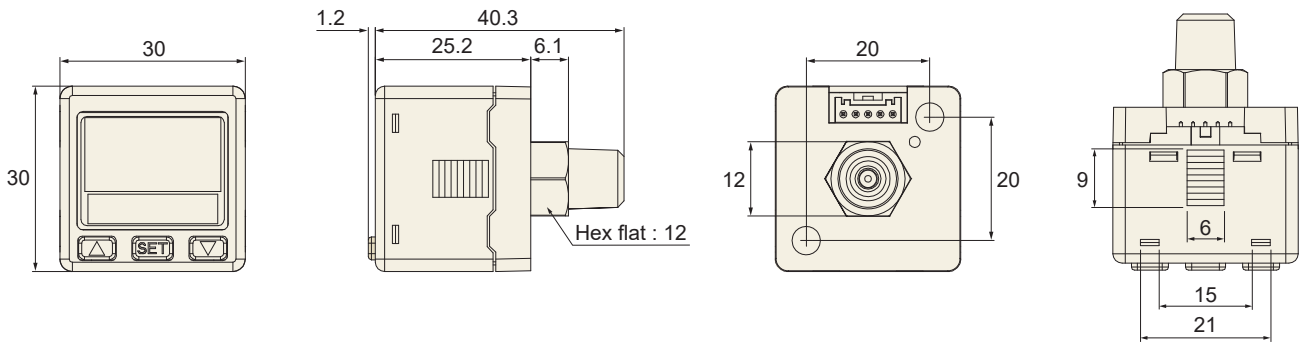

Optional Parts Dimensions

1 Mounting Bracket

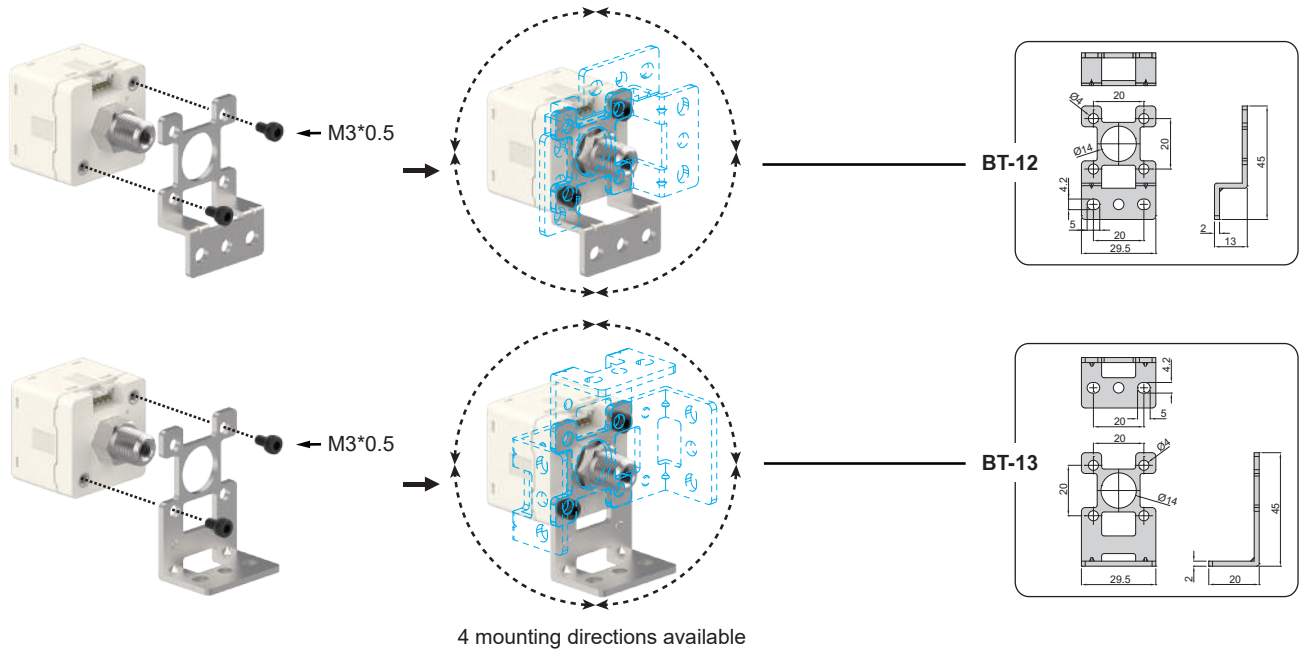

2 Panel Mount Adapter + Front Protective Lid

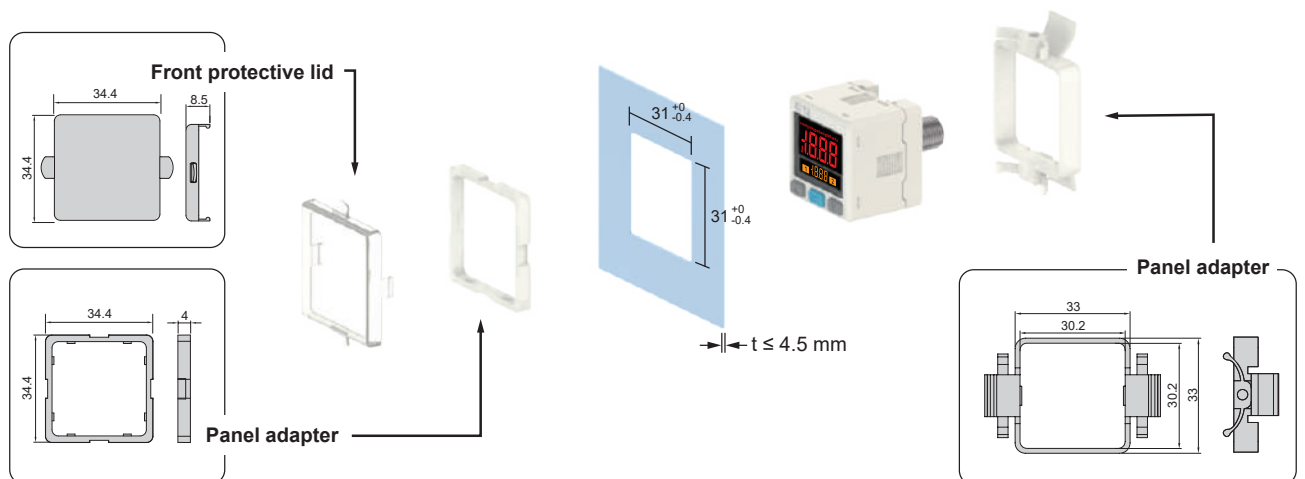

Unit : mm

KP45 SERIES

IP65 Pressure Sensor

Features

- 2-color digital LCD display
- Copy function
- Selectable pressure unit :
kPa 、 MPa 、 kgf / cm² 、 bar 、 psi 、 inHg
- IP65 enclosure

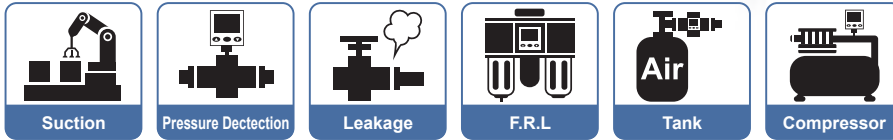

Features Highlight

1 Quick Installation

- Save installation time
- Easy removal

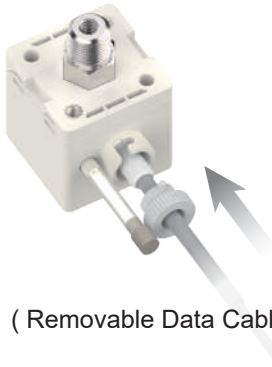

(Removable Data Cable)

2 Copy Setting

- Avoid setting errors
- Reduce setting time



(Original Parameter)

(Copied)

3 Easy Unit Identification

- Unit conversion easy to read



4 2-Color Display

- User selectable color mode, for different conditions use



	SoG	SoR	Grn	rEd
ON	Green	Red	Green	Red
OFF	Red	Green	Green	Red

5 IP65 Compliance



6 Environmental Protection Design

- RoHS Compliance / Without Harmful Substance



Specifications

MODEL		KP45C	KP45V	KP45P
		Compound	Vacuum	Positive
Rated Pressure Range		-100.0 ~ 100.0 kPa	0.0 ~ -101.3 kPa	0.000 ~ 1.000 MPa
Set Pressure Range		-101.0 ~ 101.0 kPa	10.0 ~ -101.3 kPa	-0.100 ~ 1.000 MPa
Withstand Pressure		300 kPa		1.5 MPa
Fluid		Filtered air, Non-corrosive / Non-flammable gas		
Set Pressure Resolution	kPa	0.1		-
	MPa	-		0.001
	kgf / cm ²	0.001		0.01
	bar	0.001		0.01
	psi	0.01		0.1
	inHg	0.1		-
Power Supply Voltage		12 ~ 24 V DC ± 10 %, Ripple (P-P) ≤ 10 % (UL class 2)		
Current Consumption		≤ 40 mA (with no load)		
Switch Output		2 NPN : open collector 2 outputs Max. Load Current : 125 mA Max. Supply Voltage : 30 V DC Residual Voltage : ≤ 1.5 V	2 PNP : open collector 2 outputs Max. Load Current : 125 mA Max. Supply Voltage : 24 V DC Residual Voltage : ≤ 1.5 V	
Repeatability		± 0.2 % F.S. ± 1 digit		
Hysteresis	One Point Set Mode	Adjustable ※1		
	Hysteresis Mode			
	Window Comparator Mode			
Response Time		≤ 2.5 ms (Chattering-proof function : 25 ms, 100 ms, 250 ms, 500 ms, 1000 ms and 1500 ms selectable)		
Output Short Circuit Protection		Yes		
Display		3 ½ digital, 7 segment LCD display (Red / Green / Orange) (Sampling rate : 5 times / sec.)		
Indicator Accuracy		± 2 % F.S. ± 1 digit (Ambient temperature : 25 ± 3 °C)		
Switch on Indicator		Orange Indicator 1 : OUT1 & Orange Indicator 2 : OUT2		
Analog Output (Voltage Output) ※2		Output Voltage : 1 ~ 5 V ± 2.5 % F.S. (within rated pressure range) Linearity : ± 1 % F.S. Output Impedance : about 1 kΩ		
Analog Output (Current Output) ※3		Output Current : 4 ~ 20 mA ± 2.5 % F.S. (within rated pressure range) Linearity : ± 1 % F.S. Max. Load Impedance : 250 Ω at power supply of 12 V 600 Ω at power supply of 24 V Min. Load Impedance : 50 Ω		
Environment	Enclosure	IP65 ※4		
	Ambient Temp. Range	Operation : 0 ~ 50 °C, Storage : -10 ~ 60 °C (No condensation or freezing)		
	Ambient Humidity Range	Operation / Storage : 35 ~ 85 % RH (No condensation)		
	Withstand Voltage	1000 V AC in 1-min (between case and lead wire)		
	Insulation Resistance	≥ 50 MΩ (at 500 V DC, between case and lead wire)		
	Vibration	Total amplitude 1.5 mm or 10 G, 10 Hz ~ 55 Hz ~ 10 Hz scan for 1 minute, 2 hours each direction of X, Y and Z		
	Shock	100 m/s ² (10 G), 3 times each in direction of X, Y and Z		
Temperature Characteristic		± 2 % F.S. of detected pressure (25 °C) at temp. (Range of 0 ~ 50 °C)		
Port Size		F1 : R1/8", M5 ; F2 : NPT1/8", #10-32 UNF ; F3 : G1/8" (BSPP), M5 F1C : Rc1/8" ; F2C : NPT1/8" ; F3C : G1/8" (BSPP)		
Lead Wire		Ø4 Oil-resistance cable (PVC) - 26 AWG (0.15 mm ²) - 5 cores		
Weight (with 2 Meter Lead Wire)		Approx. 86 g (Port F1 ~ F3) ; Approx. 114 g (Port F1C ~ F3C)		

NOTE

※1 : Hysteresis value is adjustable within 1 ~ 8 digits for one point set mode and window comparator mode.

※2 : If analog voltage output is selected, the analog current output cannot be selected at the same time.

※3 : If analog current output is selected, the analog voltage output cannot be selected at the same time.

※4 : Dustproof protector must be installed to maintain IP65.

KP45 SERIES

IP65 Pressure Sensor

Panel Description

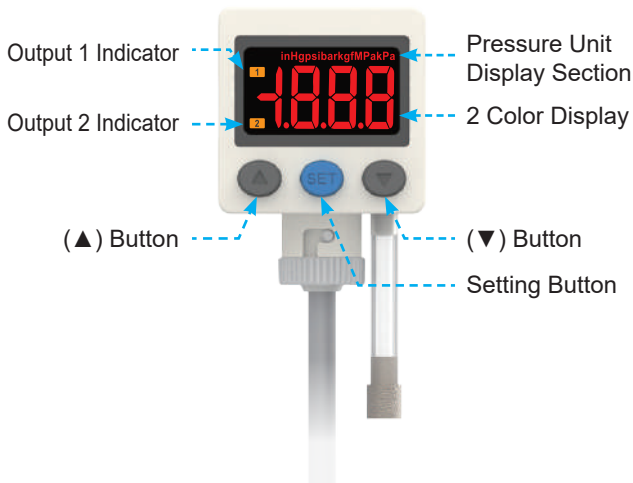

Installation Precautions

- When mounting, always use the wrench on the metallic area near the pressure port. Never apply a wrench to the plastic body, it will damage the sensor.
- Over tightening may cause damage to the port thread, mounting bracket and pressure sensor. Under tightening may result loosen or leakage.
- Apply air pressure and power after installation, make necessary adjustments and inspect any possible signs of leakage to ensure proper installation.

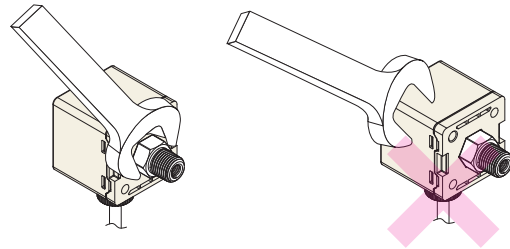

Circuit Wiring Diagrams

KP45 □ - 010 - □

2 NPN + Analog Output (1 ~ 5 V)

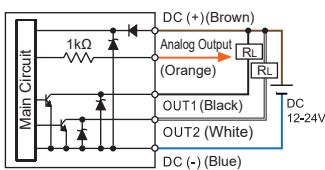

KP45 □ - 011 - □

2 NPN + Analog Output (4 ~ 20 mA)

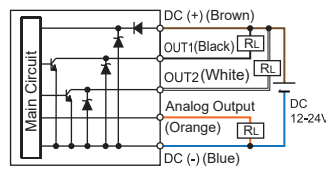

KP45 □ - 02 - □

2 NPN + Copy Function

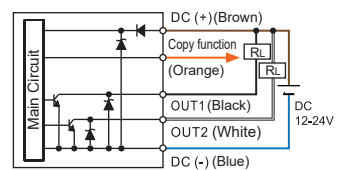

KP45 □ - 030 - □

2 PNP + Analog Output (1 ~ 5 V)

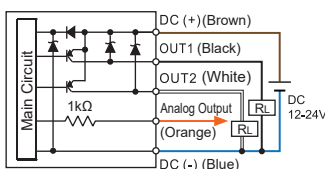

KP45 □ - 031 - □

2 PNP + Analog Output (4 ~ 20 mA)

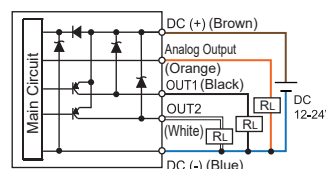

KP45 □ - 04 - □

2 PNP + Copy Function

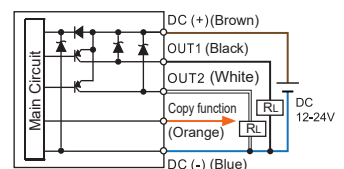

Ordering Information

K P 4 5 C - 0 1 0 - F 1

Pressure Range

C : Compound
(-101.0 ~ 101.0 kPa)
V : Vacuum
(10.0 ~ -101.3 kPa)
P : Positive
(-0.100 ~ 1.000 MPa)

Output Specifications

010 : 2 NPN Output & Analog Output (1 ~ 5 V)
011 : 2 NPN Output & Analog Output (4 ~ 20 mA)
02 : 2 NPN Output & Copy Function
030 : 2 PNP Output & Analog Output (1 ~ 5 V)
031 : 2 PNP Output & Analog Output (4 ~ 20 mA)
04 : 2 PNP Output & Copy Function

Pressure Port

F1 : R1/8", M5 , with external threads
F2 : NPT1/8", #10-32UNF,
with external threads
F3 : G1/8" (BSPP), M5,
with external threads
F1C : Rc1/8", with internal threads
F2C : NPT1/8", with internal threads
F3C : G1/8" (BSPP),
with internal threads

Optional Parts

BT-10 : Mounting bracket
(for Pressure Port F1 ~ F3)
BT-11 : Mounting bracket
(for Pressure Port F1 ~ F3)
BT-1 : Mounting bracket
(for Pressure Port F1C ~ F3C)
BT-17 : Mounting bracket
(for Pressure Port F1C ~ F3C)
PA-E : Panel adapter
PA-F : Panel adapter + Front protective lid

Optional Parts

- Mounting Bracket :
BT-10 / BT-11 (For Pressure Port F1 ~ F3)
BT-1 / BT-17 (For Pressure Port F1C ~ F3C)
- Panel Adapter : PA-E
- Panel Adapter + Front Protective Lid : PA-F



Dimensions

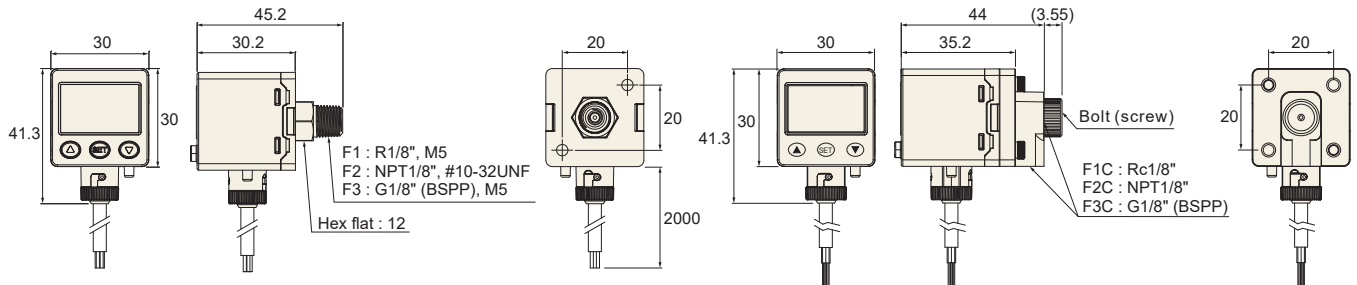

Optional Parts Dimensions

1 Mounting Bracket

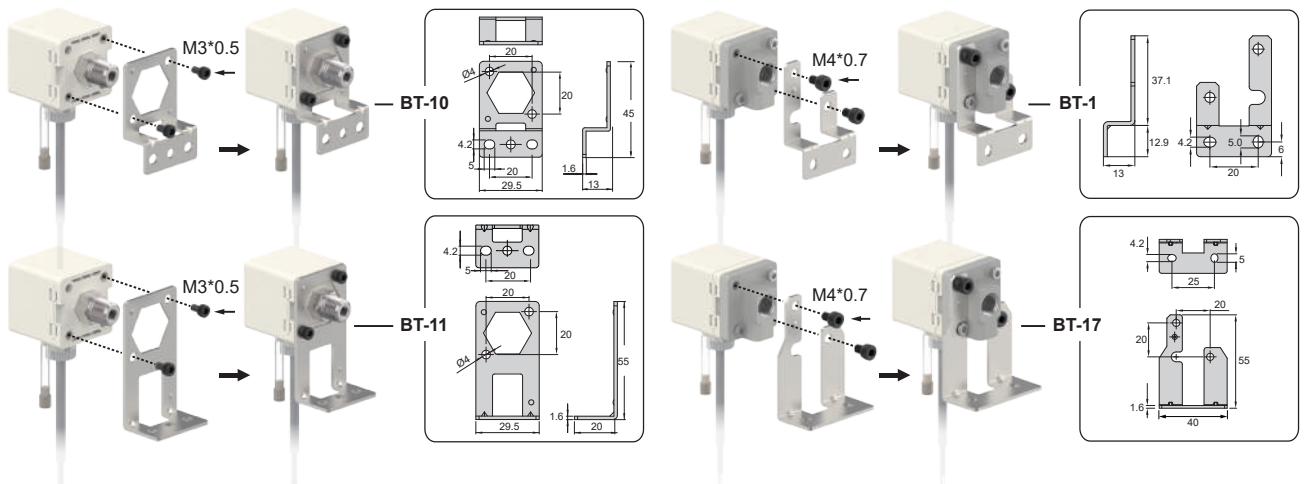

2 Panel Mount Adapter + Front Protective Lid

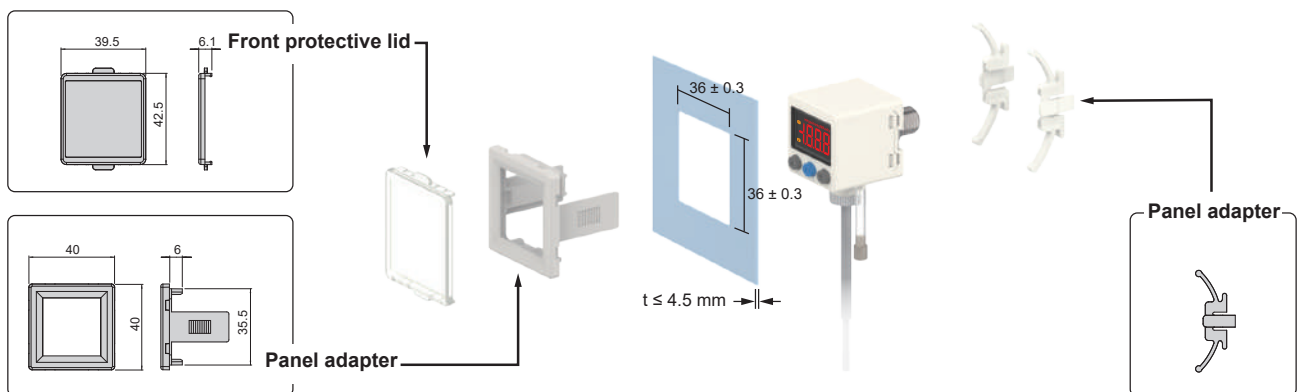

3 IP65 Protector

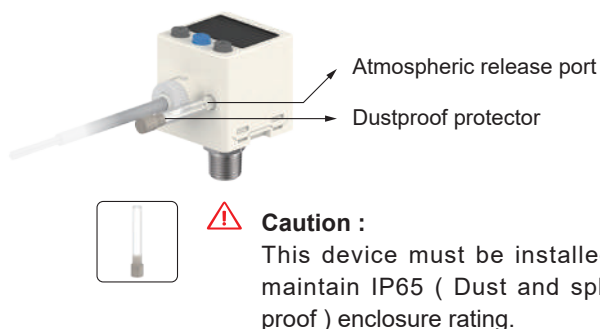

4 KP45 Accessory for Pressure Port F1C ~ F3C

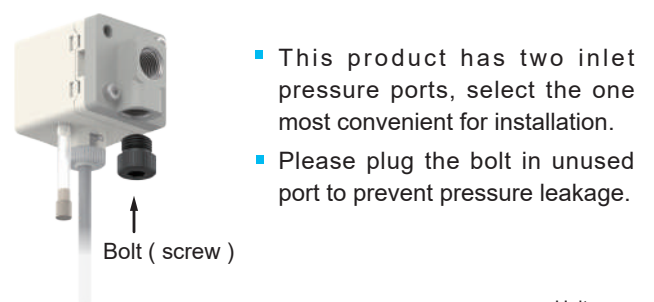

Unit : mm

Features

- 2-color digital LCD display
- Copy function
- Selectable pressure unit :
kPa 、 kgf / cm² 、 bar 、 psi 、 inHg
- IP65 enclosure



Features Highlight

1 Quick Installation

- Save installation time
- Easy removal

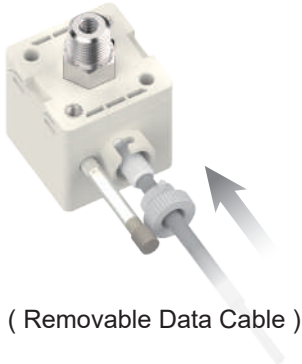

2 Copy Setting

- Avoid setting errors
- Reduce setting time

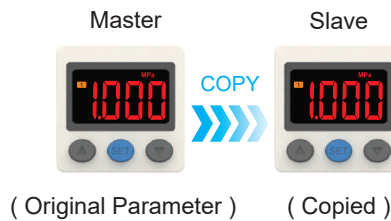

3 Easy Unit Identification

- Unit conversion easy to read



4 2-Color Display

- User selectable color mode, for different conditions use



	SoG	SoR	Grn	rEd
ON	Green	Red	Green	Red
OFF	Red	Green	Green	Red

5 IP65 Compliance



6 Environmental Protection Design

- RoHS Compliance / Without Harmful Substance





Specifications

MODEL		KP45S	
		Compound	
Rated Pressure Range		-10.00 ~ 10.00 kPa	
Set Pressure Range		-10.10 ~ 10.10 kPa	
Withstand Pressure		20 kPa	
Fluid		Filtered air, Non-corrosive / Non-flammable gas	
Set Pressure Resolution	kPa	0.01	
	MPa	-	
	kgf / cm ²	0.001	
	bar	0.001	
	psi	0.01	
	inHg	0.1	
Power Supply Voltage		12 ~ 24 V DC \pm 10 %, Ripple (P-P) \leq 10 %	
Current Consumption		\leq 40 mA (with no load)	
Switch Output		2 NPN : open collector 2 outputs Max. Load Current : 125 mA Max. Supply Voltage : 30 V DC Residual Voltage : \leq 1.5 V	2 PNP : open collector 2 outputs Max. Load Current : 125 mA Max. Supply Voltage : 24 V DC Residual Voltage : \leq 1.5 V
Repeatability		\pm 0.2 % F.S. \pm 1 digit	
Hysteresis	One Point Set Mode	Adjustable ※1	
	Hysteresis Mode		
	Window Comparator Mode		
Response Time		\leq 2.5 ms (Chattering-proof function : 25 ms, 100 ms, 250 ms, 500 ms, 1000 ms and 1500 ms selectable)	
Output Short Circuit Protection		Yes	
Display		3 ½ digital, 7 segment LCD display (Red / Green / Orange) (Sampling rate : 5 times / sec.)	
Indicator Accuracy		\pm 2 % F.S. \pm 1 digit (Ambient temperature : 25 \pm 3 °C)	
Switch on Indicator		Orange Indicator 1 : OUT1 & Orange Indicator 2 : OUT2	
Analog Output (Voltage Output) ※2		Output Voltage : 1 ~ 5 V \pm 2.5 % F.S. (within rated pressure range) Linearity : \pm 1 % F.S. Output Impedance : about 1 k Ω	
Analog Output (Current Output) ※3		Output Current : 4 ~ 20 mA \pm 2.5 % F.S. (within rated pressure range) Linearity : \pm 1 % F.S. Max. Load Impedance : 250 Ω at power supply of 12 V 600 Ω at power supply of 24 V Min. Load Impedance : 50 Ω	
Environment	Enclosure	IP65 ※4	
	Ambient Temp. Range	Operation : 0 ~ 50 °C, Storage : -10 ~ 60 °C (No condensation or freezing)	
	Ambient Humidity Range	Operation / Storage : 35 ~ 85 % RH (No condensation)	
	Withstand Voltage	1000 V AC in 1-min (between case and lead wire)	
	Insulation Resistance	\geq 50 M Ω (at 500 V DC, between case and lead wire)	
	Vibration	Total amplitude 1.5 mm or 10 G, 10 Hz ~ 55 Hz ~ 10 Hz scan for 1 minute, 2 hours each direction of X, Y and Z	
Shock		100 m/s ² (10 G), 3 times each in direction of X, Y and Z	
Temperature Characteristic		\pm 2 % F.S. of detected pressure (25 °C) at temp. (Range of 0 ~ 50 °C)	
Port Size		F1 : R1/8", M5 ; F2 : NPT1/8", #10-32UNF ; F3 : G1/8" (BSPP), M5 F1C : Rc1/8" ; F2C : NPT1/8" ; F3C : G1/8" (BSPP)	
Lead Wire		\varnothing 4 Oil-resistance cable (PVC) - 26 AWG (0.15 mm ²) - 5 cores	
Weight (with 2 Meter Lead Wire)		Approx. 86 g (Port F1 ~ F3) ; Approx. 114 g (Port F1C ~ F3C)	

NOTE

※1 : Hysteresis value is adjustable within 1 ~ 8 digits for one point set mode and window comparator mode.

※2 : If analog voltage output is selected, the analog current output cannot be selected at the same time.

※3 : If analog current output is selected, the analog voltage output cannot be selected at the same time.

※4 : Dustproof protector must be installed to maintain IP65.

KP45S SERIES

IP65 Low Pressure Sensor

Panel Description



Installation Precautions

- When mounting, always use the wrench on the metallic area near the pressure port. Never apply a wrench to the plastic body, it will damage the sensor.
- Over tightening may cause damage to the port thread, mounting bracket and pressure sensor. Under tightening may result loosen or leakage.
- Apply air pressure and power after installation, make necessary adjustments and inspect any possible signs of leakage to ensure proper installation.

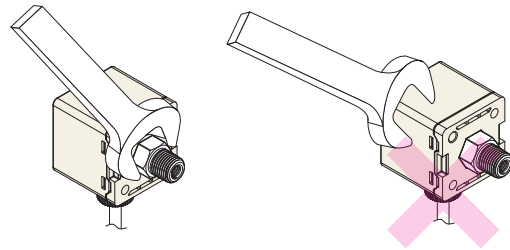

Circuit Wiring Diagrams

KP45S □ - 010 - □
2 NPN + Analog Output (1 ~ 5 V)

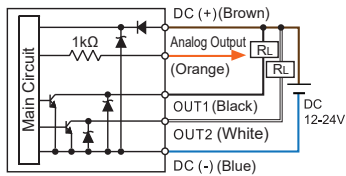

KP45S □ - 011 - □
2 NPN + Analog Output (4 ~ 20 mA)

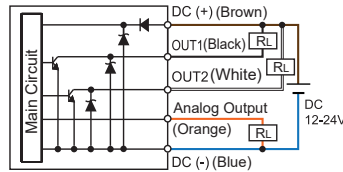

KP45S □ - 02 - □
2 NPN + Copy Function

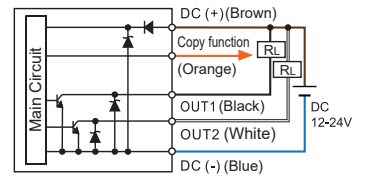

KP45S □ - 030 - □
2 PNP + Analog Output (1 ~ 5 V)

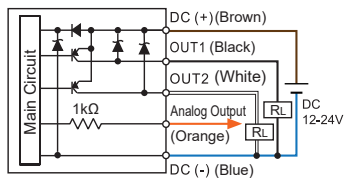

KP45S □ - 031 - □
2 PNP + Analog Output (4 ~ 20 mA)

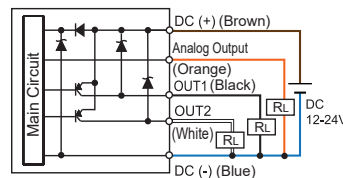

KP45S □ - 04 - □
2 PNP + Copy Function

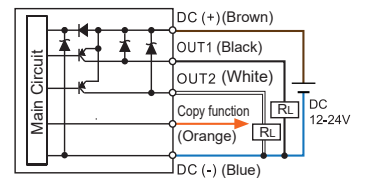

Ordering Information

K P 4 5 S - 0 1 0 - F 1

Pressure Range

S : Compound (-10.10 ~ 10.10 kPa)

Output Specifications

- 010 : 2 NPN Output & Analog Output (1 ~ 5 V)
- 011 : 2 NPN Output & Analog Output (4 ~ 20 mA)
- 02 : 2 NPN Output & Copy Function
- 030 : 2 PNP Output & Analog Output (1 ~ 5 V)
- 031 : 2 PNP Output & Analog Output (4 ~ 20 mA)
- 04 : 2 PNP Output & Copy Function

Pressure Port

- F1 : R1/8", M5, with external threads
- F2 : NPT1/8", #10-32UNF, with external threads
- F3 : G1/8" (BSPP), M5, with external threads
- F1C : Rc1/8", with internal threads
- F2C : NPT1/8", with internal threads
- F3C : G1/8" (BSPP), with internal threads

Optional Parts

- BT-10 : Mounting bracket (for Pressure Port F1 ~ F3)
- BT-11 : Mounting bracket (for Pressure Port F1 ~ F3)
- BT-1 : Mounting bracket (for Pressure Port F1C ~ F3C)
- BT-17 : Mounting bracket (for Pressure Port F1C ~ F3C)
- PA-E : Panel adapter
- PA-F : Panel adapter + Front protective lid

Optional Parts

- Mounting Bracket :
BT-10 / BT-11 (For Pressure Port F1 ~ F3)
BT-1 / BT-17 (For Pressure Port F1C ~ F3C)

- Panel Adapter : PA-E

- Panel Adapter + Front Protective Lid : PA-F



Dimensions

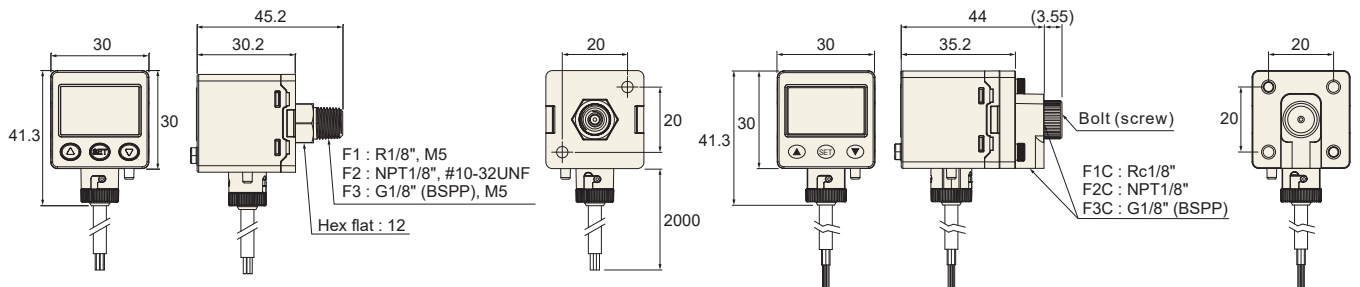

Optional Parts Dimensions

1 Mounting Bracket

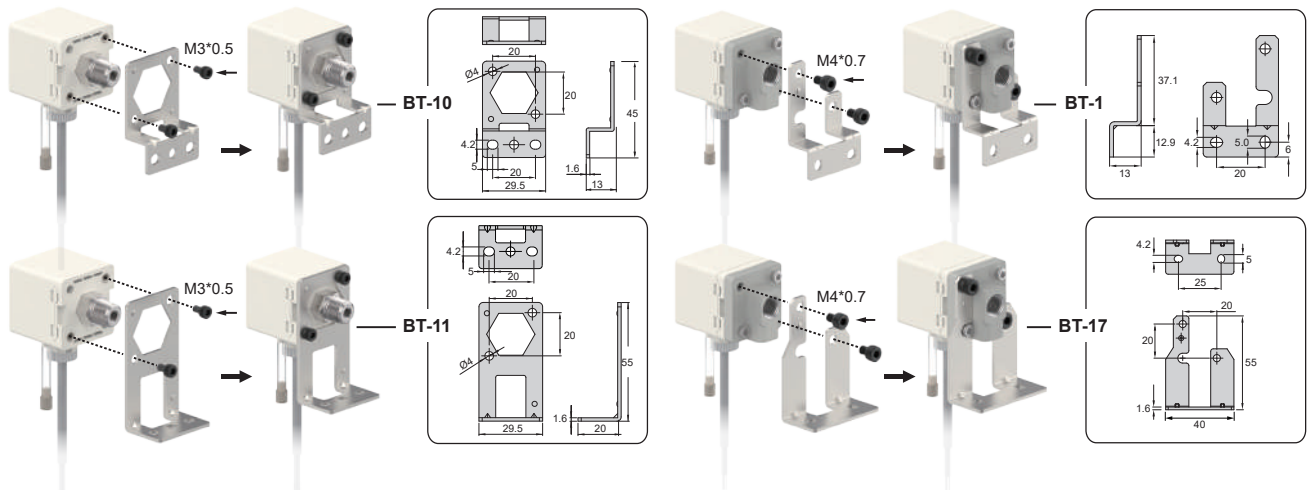

2 Panel Mount Adapter + Front Protective Lid

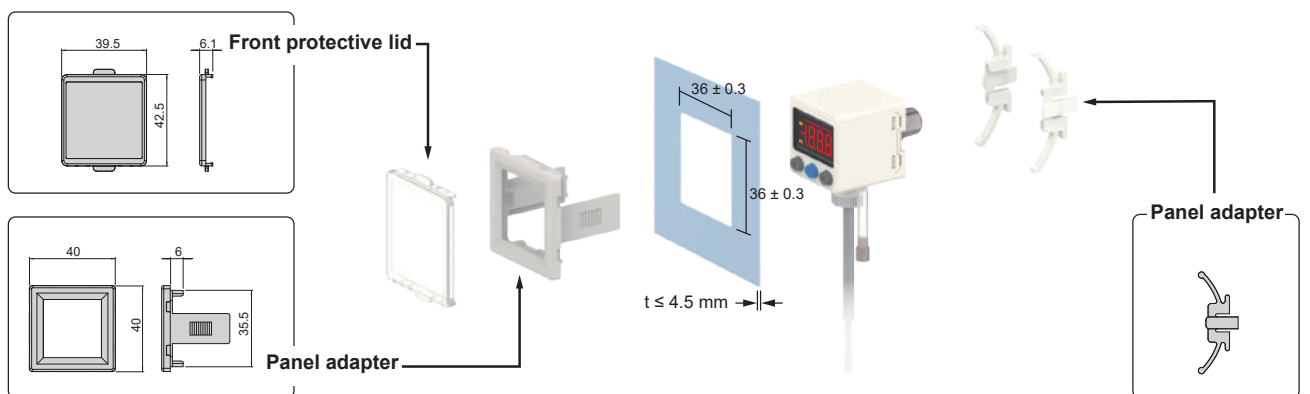

3 IP65 Protector

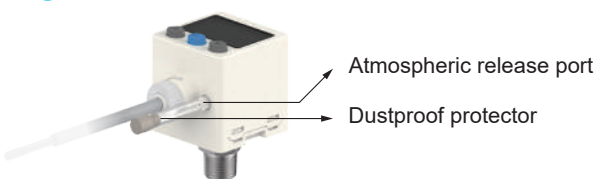

Caution :

This device must be installed to maintain IP65 (Dust and splash proof) enclosure rating.

4 KP45S Accessory for Pressure Port F1C ~ F3C



- This product has two inlet pressure ports, select the one most convenient for installation.
- Please plug the bolt in unused port to prevent pressure leakage.

Unit : mm

KP47 SERIES

Economical Pressure Sensor

Features

- 3-color digital LCD display
- Main / Sub-Display, 4 digits 7 segment LCD display
- Selectable pressure unit :
kPa、MPa、kgf/cm²、bar、psi、inHg、mmHg
- Dual LCD display allows setting value to be displayed
- Key-lock indicator
- Power-save mode
- Fine adjustment mode

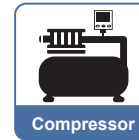
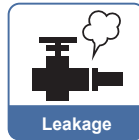
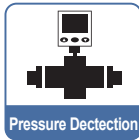
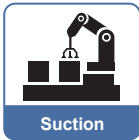

Features Highlight

1 Quick Installation

- Save installation time
- Easy removal

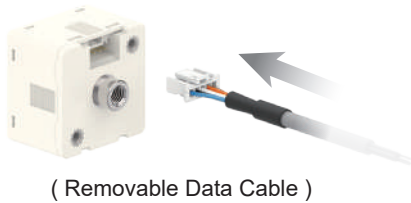

2 Compact design

- Compared with similar products, approx. 35 % shorter

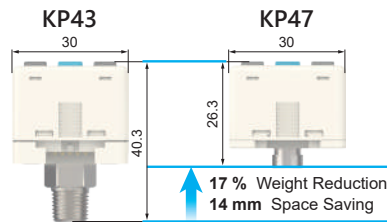

3 Setting Value Easy Indication

- User can easily observe the setting value from sub-display

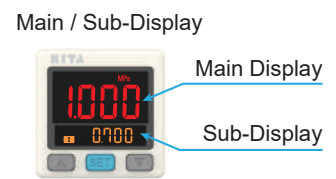

4 2-Color Main Display

- User selectable color mode, for different conditions use



	SoG	SoR	Grn	rEd
ON	Green	Red	Green	Red
OFF	Red	Green	Green	Red

5 OPS Quick Setting

- Sub-display allows changing the parameter directly, reduce setting step by 3/4

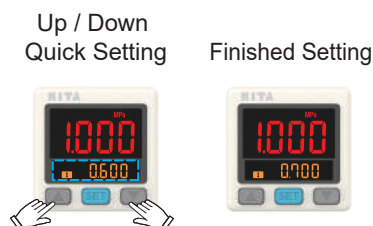

6 Easy Unit Identification

- Unit conversion easy to read



Specifications

MODEL	KP47C	KP47V	KP47P	KP47S
	Compound	Vacuum	Positive	Micro-pressure
Rated Pressure Range	-100.0 ~ 100.0 kPa	0.0 ~ -101.3 kPa	-0.100 ~ 1.000 MPa	-10.00 ~ 10.00 kPa ※1
Set Pressure Range	-103.0 ~ 103.0 kPa	10.0 ~ -103.0 kPa	-0.103 ~ 1.030 MPa	-10.10 ~ 10.10 kPa ※1
Withstand Pressure	500 kPa		1.5 MPa	20 kPa
Fluid	Filtered air, Non-corrosive / Non-flammable gas			
Set Pressure Resolution	kPa	0.1	-	0.01
	MPa	-	0.001	-
	kgf / cm ²	0.001	0.01	-
	bar	0.001	0.01	-
	psi	0.01	0.1	-
	inHg	0.1	-	-
	mmHg	1	-	-
Power Supply Voltage	12 ~ 24 V DC ± 10 %, Ripple (P-P) ≤ 10 %			
Current Consumption	≤ 30 mA (with no load)			
Switch Output	NPN : open collector outputs Max. Load Current : 80 mA Max. Supply Voltage : 30 V DC Residual Voltage : ≤ 1 V		PNP : open collector outputs Max. Load Current : 80 mA Max. Supply Voltage : 24 V DC Residual Voltage : ≤ 1 V	
Repeatability	± 0.3 % F.S. ± 1 digit			≤ ± 0.4 kPa
Hysteresis	One Point Set Mode	Adjustable ※2		
	Hysteresis Mode			
	Window Comparator Mode			
Response Time	≤ 2.5 ms (Chattering-proof function : 25 ms, 100 ms, 250 ms, 500 ms, 1000 ms and 1500 ms selections)			
Output Short Circuit Protection	Yes			
Display	4 digital, 7 segment LCD display (Red / Green / Orange) (Sampling rate : 0.2, 0.5, 1 sec. / time)			
Indicator Accuracy	± 1 % F.S. ± 1 digit (Ambient temperature : 25 ± 3 °C)			≤ ± 0.4 kPa
Switch on Indicator	Orange Indicator 1 : OUT1 & Orange Indicator 2 : OUT2			
Analog Output (Voltage Output)	Output Voltage : 1 ~ 5 V ± 2.5 % F.S. (within rated pressure range) ; Linearity : ± 1 % F.S. ; Output Impedance : about 1 kΩ		Output Voltage : 0.6 ~ 5 V ± 2.5 % F.S. (within rated pressure range) ; Linearity : ± 1 % F.S. ; Output Impedance : about 1 kΩ	Output Voltage : 1 ~ 5 V ± 2.5 % F.S. (within rated pressure range) ; Linearity : ± 1 % F.S. ; Output Impedance : about 1 kΩ
	Enclosure	IP40		
	Environment	Ambient Temp. Range	Operation : 0 ~ 50 °C, Storage : -10 ~ 60 °C (No condensation or freezing)	
Ambient Humidity Range		Operation / Storage : 35 ~ 85 % RH (No condensation)		
Withstand Voltage		1000 V AC in 1-min (between case and lead wire)		
Insulation Resistance		≥ 50 MΩ (at 500 V DC, between case and lead wire)		
Vibration		Total amplitude 1.5 mm or 10 G, 10 Hz ~ 150 Hz ~ 10 Hz scan for 1 minute, 2 hours each direction of X, Y and Z		
Shock		100 m/s ² (10 G), 3 times each in direction of X, Y and Z		
Temperature characteristic	± 2 % F.S. of detected pressure (25 °C) at temp. (Range of 0 ~ 50 °C)			± 0.4 kPa of detected pressure (25 °C) at temp. (Range of 0 ~ 50 °C)
Port size	F1 : R1/8", M5 ; F2 : NPT1/8", #10~32 UNF ; F3 : G1/8" (BSPP), M5 ; M5 : M5 female thread			
Lead wire	Ø4 Oil-resistance cable (PVC) - 26 AWG (0.15 mm ²) - 4 cores			
Weight (with 2 meter lead wire)	Approx. 67 g			

NOTE

※1 : Selectable pressure ranges (S-01 ~ S-09).

※2 : Hysteresis value is adjustable within 1 ~ 8 digits for one point set mode and window comparator mode.

KP47 SERIES

Economical Pressure Sensor

Panel Description

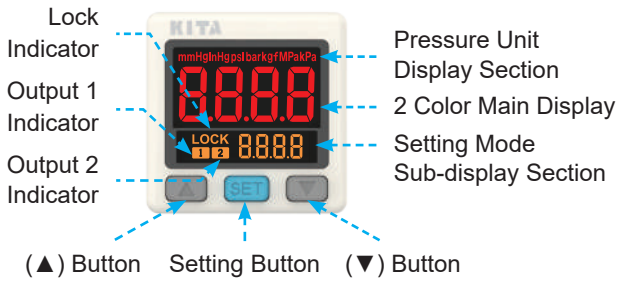

Installation Precautions

- When mounting, always use the wrench on the metallic area near the pressure port. Never apply a wrench to the plastic body, it will damage the sensor.
- Over tightening may cause damage to the port thread, mounting bracket and pressure sensor. Under tightening may result loosen or leakage.
- Apply air pressure and power after installation, make necessary adjustments and inspect any possible signs of leakage to ensure proper installation.

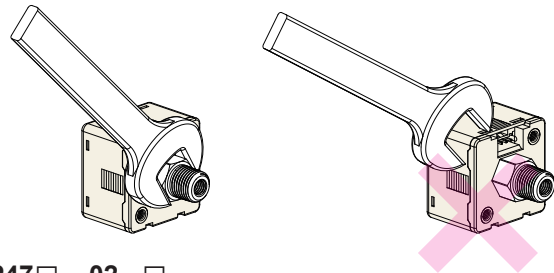

Circuit Wiring Diagrams

KP47□ - 01 - □

1NPN + Analog output (1 ~ 5 V) (0.6 ~ 5 V only positive)

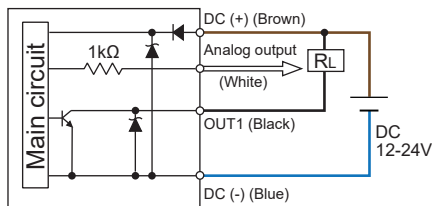

KP47□ - 02 - □

2NPN + output

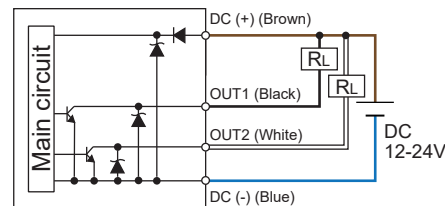

KP47□ - 03 - □

1PNP + Analog output (1 ~ 5 V) (0.6 ~ 5 V only positive)

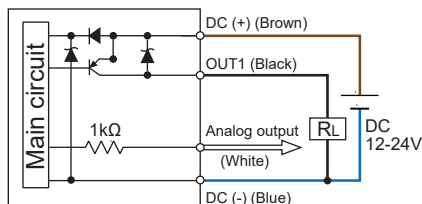

KP47□ - 04 - □

2PNP + output

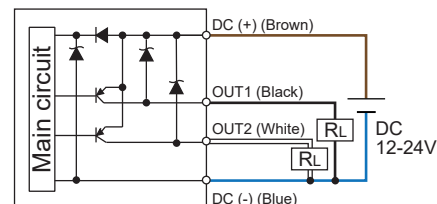

Ordering Information

K P 4 7 C - 0 1 - F 1

Pressure Range

C : Compound (-103.0 ~ 103.0 kPa)
 V : Vacuum (10.0 ~ -103.0 kPa)
 P : Positive (-0.103 ~ 1.030 MPa)
 S : Micro-pressure (-10.00 ~ 10.00 kPa)

Output Specifications

01 : 1 NPN output + Analog output (1 ~ 5 V)
 02 : 2 NPN output
 03 : 1 PNP output + Analog output (1 ~ 5 V)
 04 : 2 PNP output

Pressure Port

F1 : R1/8", M5
 F2 : NPT1/8", #10-32UNF
 F3 : G1/8" (BSPP), M5
 M5 : M5 female thread

Optional Parts

BT-22 : Mounting bracket
 BT-23 : Mounting bracket
 PA-C : Panel adapter
 PA-D : Panel adapter + Front protective lid

Optional Parts

■ Mounting Bracket : BT-22 / BT-23

■ Panel Adapter : PA-C

■ Panel Adapter + Front Protective Lid : PA-D



Dimensions

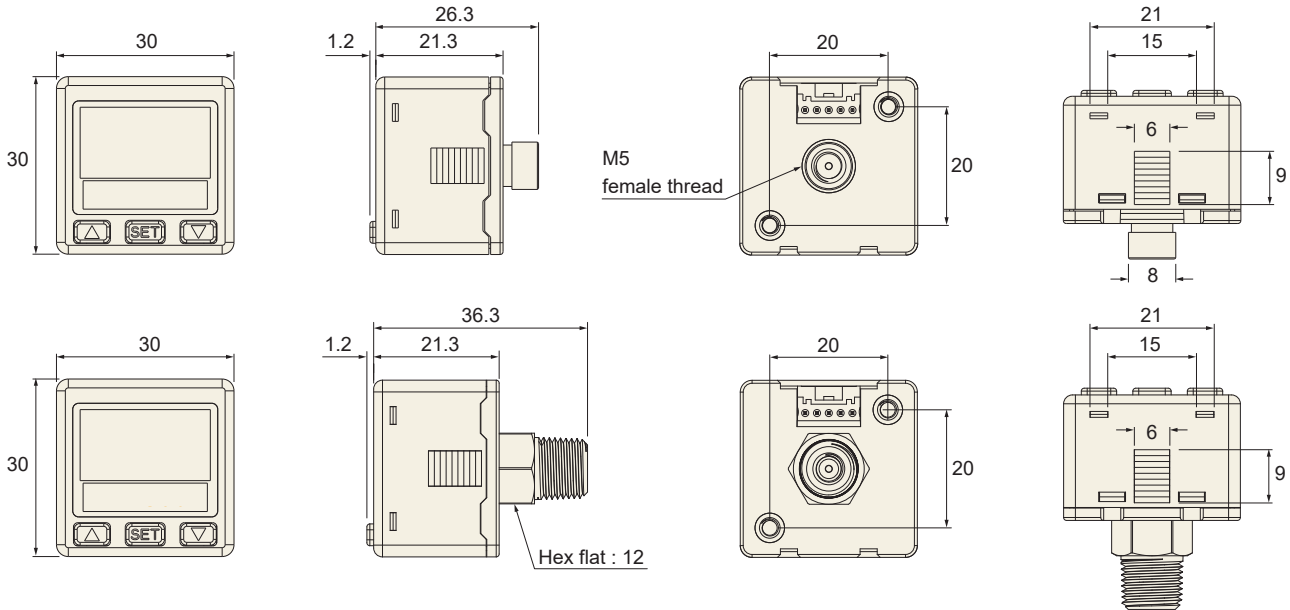

Optional Parts Dimensions

1 Mounting Bracket

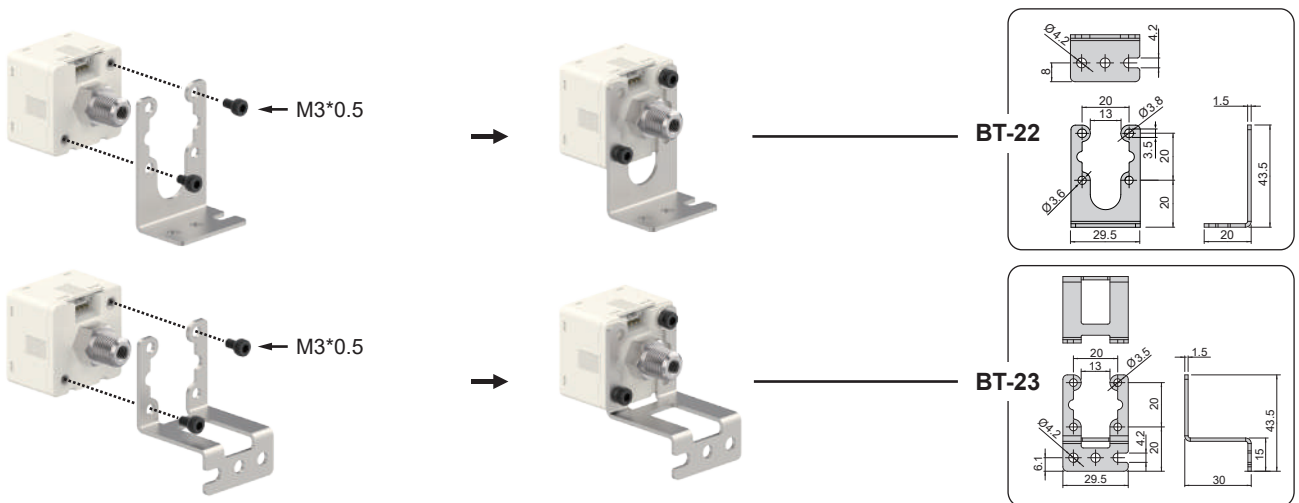

2 Panel Mount Adapter + Front Protective Lid

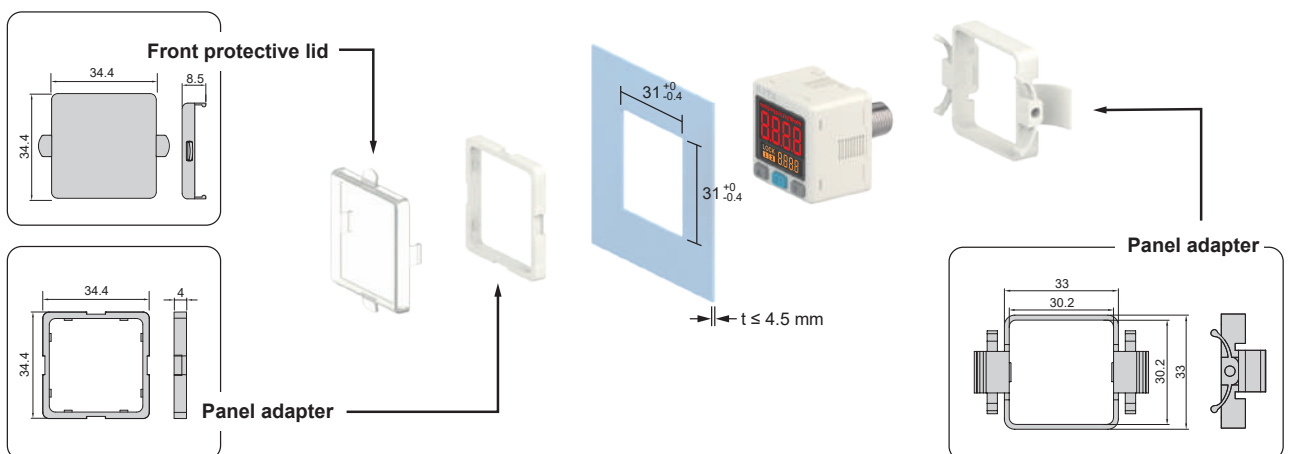

Unit : mm

KP50E SERIES

Pneumatic · Hydraulic Pressure Sensor (Multi-Medium)

Features

- Corrosive fluid or gas available (in the pipeline)
- Sensor parts & Fitting parts : SUS316L
- 2-color digital LCD display
- Copy function
- Selectable pressure unit :
kPa · MPa · kgf / cm² · bar · psi · inHg
- IP65 enclosure

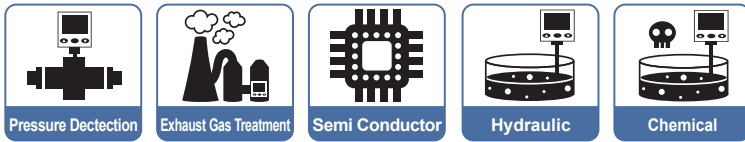

Features Highlight

1 Quick Installation

- Save installation time
- Easy removal

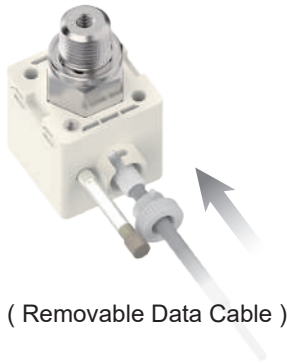

2 Copy Setting

- Avoid setting errors
- Reduce setting time



3 Easy Unit Identification

- Unit conversion easy to read

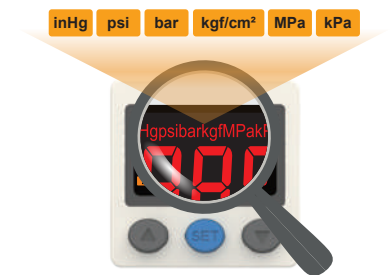

4 Applicable for Corrosive Fluid or Gas

- Sensor parts & Fitting parts are SUS316L, applicable for corrosive fluid or gas equipment

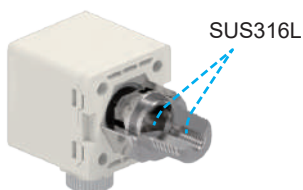

5 2-Color Display

- User selectable color mode, for different conditions use



	SoG	SoR	Grn	rEd
ON	Green	Red	Green	Red
OFF	Red	Green	Green	Red

6 IP65 Compliance



Specifications

MODEL	KP50EC	KP50EV	KP50EP	KP50EH
	Compound	Vacuum	Positive	High
Rated Pressure Range	-100.0 ~ 100.0 kPa	0.0 ~ -101.3 kPa	0.000 ~ 1.000 MPa	0.000 ~ 2.00 MPa
Set Pressure Range	-101.0 ~ 101.0 kPa	10.0 ~ -101.3 kPa	-0.100 ~ 1.000 MPa	-0.100 ~ 2.00 MPa
Withstand Pressure	300 kPa		3 MPa	
Fluid	Fluid or air that will not corrode SUS316L			
Sealed Liquid	Silicon oil			
Set Pressure Resolution	kPa	0.1	-	-
	MPa	-	0.001	0.001 (~1.999) 0.01 (2.00~)
	kgf / cm ²	0.001	0.01	0.01 (~19.99) 0.1 (20.0~)
	bar	0.001	0.01	0.01 (~19.99) 0.1 (20.0~)
	psi	0.01	0.1	0.1 (~199.9) 1 (200~)
	inHg	0.1	-	-
Power Supply Voltage	12 ~ 24 V DC ± 10 %, Ripple (P-P) ≤ 10 %			
Current Consumption	≤ 40 mA (with no load)			
Switch Output	2 NPN : open collector 2 outputs Max. Load Current : 125 mA Max. Supply Voltage : 30 V DC Residual Voltage : ≤ 1.5 V		2 PNP : open collector 2 outputs Max. Load Current : 125 mA Max. Supply Voltage : 24 V DC Residual Voltage : ≤ 1.5 V	
Repeatability	± 0.3 % F.S. ± 1 digit			
Hysteresis	One point set mode	Adjustable ※1		
	Hysteresis mode			
	Window comparator mode			
Response Time	≤ 2.5 ms (Chattering-proof function : 25 ms, 100 ms, 250 ms, 500 ms, 1000 ms and 1500 ms selectable)			
Output Short Circuit Protection	Yes			
Display	3 ½ digital, 7 segment LCD display (Red / Green / Orange) (Sampling rate : 5 times / sec.)			
Indicator Accuracy	± 2 % F.S. ± 1 digit (Ambient temperature : 25 ± 3 °C)			
Switch on Indicator	Orange Indicator 1 : OUT1 & Orange Indicator 2 : OUT2			
Analog Output (Voltage Output) ※2	Output Voltage : 1 ~ 5 V ± 2.5 % F.S. (within rated pressure range) Linearity : ± 1 % F.S. Output Impedance : about 1 kΩ			
Analog Output (Current Output) ※3	Output Current : 4 ~ 20 mA ± 2.5 % F.S. (within rated pressure range) Linearity : ± 1 % F.S. Max. Load Impedance : 250 Ω at power supply of 12 V, 600 Ω at power supply of 24 V Min. Load Impedance : 50 Ω			
Environment	Enclosure	IP65 ※4		
	Ambient Temp. Range	Operation : 0 ~ 50 °C, Storage : -10 ~ 60 °C (No condensation or freezing)		
	Ambient Humidity Range	Operation / Storage : 35 ~ 85 % RH (No condensation)		
	Withstand Voltage	250 V AC in 1-min (between case and lead wire)		
	Insulation Resistance	≥ 50 MΩ (at 500 V DC, between case and lead wire)		
	Vibration	Total amplitude 1.5 mm or 10 G, 10 Hz ~ 55 Hz ~ 10 Hz scan for 1 minute, 2 hours each direction of X, Y and Z		
	Shock	100 m/s ² (10 G), 3 times each in direction of X, Y and Z		
Temperature Characteristic	± 3 % F.S. of detected pressure (25 °C) at temp. (Range of 0 ~ 50 °C)			
Port Size ※5	F1 : R1/4", M5 ; F2 : NPT1/4", #10-32 UNF ; F3 : G1/4" (BSPP), M5 ; F1C : Rc1/8"			
Lead Wire	Ø4 Oil-resistance cable (PVC) - 26 AWG (0.15 mm ²) - 5 cores			
Weight (with 2 Meter Lead Wire)	Approx. 110 g (Rear ported) ; Approx. 150 g (Bottom ported)			

NOTE

※1 : Hysteresis value is adjustable within 1 ~ 8 digits for one point set mode and window comparator mode.

※2 : If analog voltage output is selected, the analog current output cannot be selected at the same time.

※3 : If analog current output is selected, the analog voltage output cannot be selected at the same time.

※4 : Dustproof protector must be installed to maintain IP65.

※5 : G port O-Ring material is NBR. if any special request, please contact KITA.

KP50E SERIES

Pneumatic · Hydraulic Pressure Sensor (Multi-Medium)

Panel Description



Installation Precautions

- When mounting, always use the wrench on the metallic area near the pressure port. Never apply a wrench to the plastic body, it will damage the sensor.
- Over tightening may cause damage to the port thread, mounting bracket and pressure sensor. Under tightening may result loosen or leakage.
- Apply air pressure and power after installation, make necessary adjustments and inspect any possible signs of leakage to ensure proper installation.

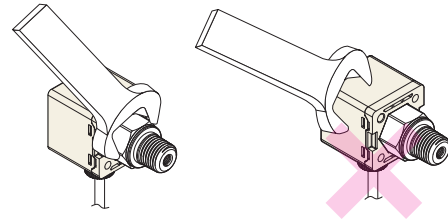

Circuit Wiring Diagrams

KP50E□ - 010 - □
2NPN + Analog Output (1 ~ 5 V)

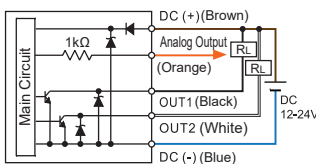

KP50E□ - 011 - □
2NPN + Analog Output (4 ~ 20 mA)

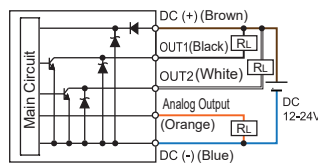

KP50E□ - 02 - □
2NPN + Copy Function

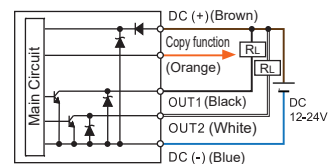

KP50E□ - 030 - □
2PNP + Analog Output (1 ~ 5 V)

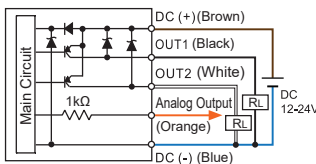

KP50E□ - 031 - □
2PNP + Analog Output (4 ~ 20 mA)

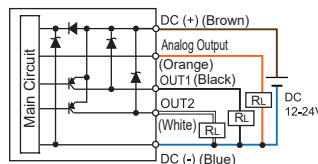

KP50E□ - 04 - □
2PNP + Copy Function

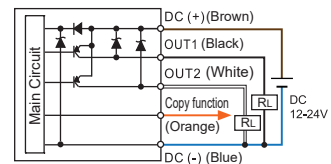

Ordering Information

K P 5 0 E H - 0 1 0 - F 1 □

Pressure Range

H : High (-0.100 ~ 2.00 MPa)
C : Compound (-101.0 ~ 101.0 kPa)
V : Vacuum (10.0 ~ -101.3 kPa)
P : Positive (-0.100 ~ 1.000 MPa)

Output Specifications

010 : 2 NPN Output & Analog Output (1 ~ 5 V)
011 : 2 NPN Output & Analog Output (4 ~ 20 mA)
02 : 2 NPN Output & Copy Function
030 : 2 PNP Output & Analog Output (1 ~ 5 V)
031 : 2 PNP Output & Analog Output (4 ~ 20 mA)
04 : 2 PNP Output & Copy Function

Pressure Port

F1 : R1/4", M5
F2 : NPT1/4", #10-32UNF
F3 : G1/4" (BSPP), M5
F1C : Rc1/8" (only with rear ported)

Piping Direction

Blank : Rear ported
L : Bottom ported

Optional Parts

BT-10 : Mounting bracket
BT-11 : Mounting bracket
PA-E : Panel adapter
PA-F : Panel adapter + Front protective lid
I-0360 : Snubber (for Pressure Port F1 & F3)
I-0379 : Snubber (for Pressure Port F2)
* KP50EP & KP50EH suggested to select a snubber

Optional Parts

- Mounting Bracket : BT-10 / BT-11
- Panel Adapter : PA-E
- Panel Adapter + Front Protective Lid : PA-F
- Snubber



I-0360 : for Pressure Port F1 & F3
I-0379 : for Pressure Port F2

Removable Snubber Installed

- Pressure port equipped with snubber can avoid damage caused by sudden pressure surge of water or oil, improve product durability.

* When snubber is clogged with contaminants, please use a flat head screwdriver to remove the snubber, clean and reinstall.

* A snubber is not applied to F1C port.

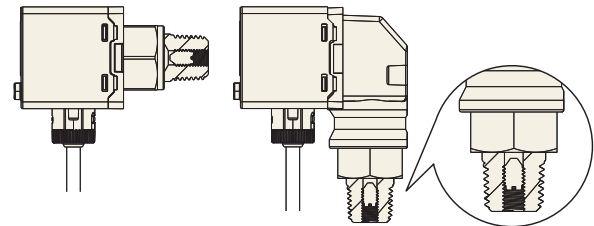

Dimensions

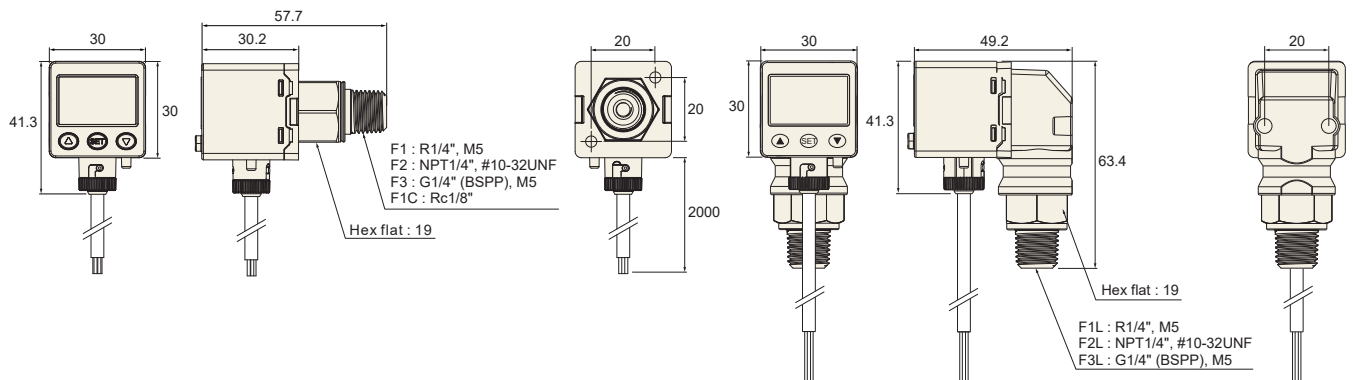

Optional Parts Dimensions

1 Mounting Bracket

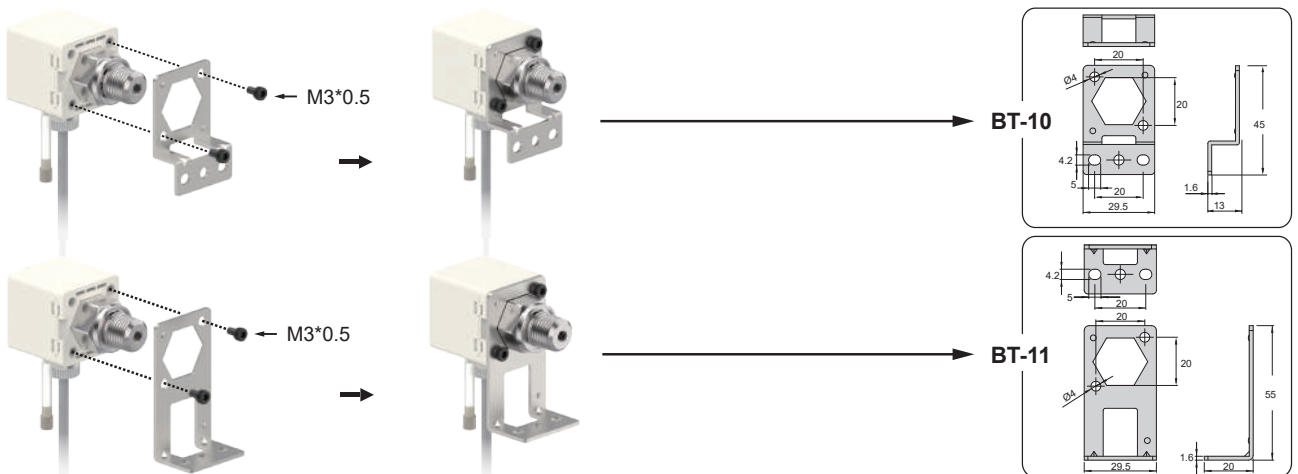

2 Panel Mount Adapter + Front Protective Lid

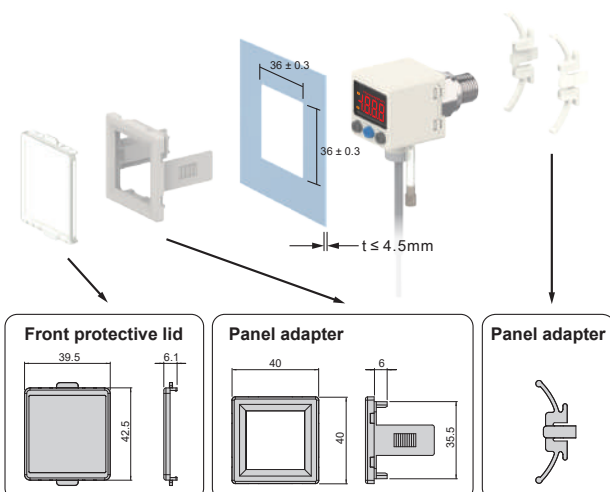

3 IP65 Protector

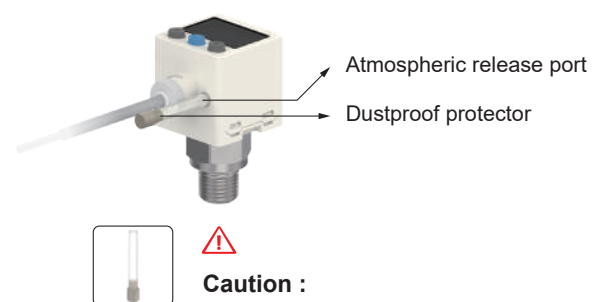

This device must be installed to maintain IP65 (Dust and splash proof) enclosure rating.

Unit : mm

KP60 SERIES

Battery Pressure Gauge

Features

- Digital pressure gauge with battery power
- Selectable pressure unit :
kPa 、 MPa 、 kgf / cm² 、 bar 、 psi 、 mmHg
- Power save function
- Battery meter displayed on LCD
- Backlight type available
- IP65 enclosure

Patented

Battery Meter

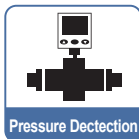

Specifications

MODEL	KP60V	KP60VL	KP60P	KP60PL
	Vacuum		Positive	
Rated Pressure Range	0 ~ -101 kPa		0.000 ~ 1.000 MPa	
Display Pressure Range	10 ~ -101 kPa		-0.100 ~ 1.000 MPa	
Withstand Pressure	300 kPa		1.5 MPa	
Applicable Fluid	Filtered air, Non-corrosive / Non-flammable gas			
Pressure Resolution	kPa	1	-	
	MPa	-	0.001	
	kgf / cm ²	-	0.01	
	bar	0.01	0.01	
	psi	0.1	0.1	
	mmHg	1	-	
Battery	CR 2032 lithium			
Back Light	No	Yes	No	Yes
Battery Life	3 years (5 times / day)	1 year (5 times / day)	3 years (5 times / day)	1 year (5 times / day)
Low-Power Indicator	Yes			
Battery Replaceable	Yes			
Turn-On Interval	Display turn off after 60 sec.			
Sampling Rate	2 Hz (2 times / sec.)			
Programmable Pressure Unit	psi, bar, mmHg, kPa		psi, bar, kgf / cm ² , MPa	
Repeatability	± 1 % F.S. ± 1 digit		± 0.2 % F.S. ± 1 digit	
Display	3 ½ digital, 7 segment LCD display (Black)			
Indicator Accuracy	± 2 % F.S. ± 1 digit (Ambient temperature : 25 ± 3 °C)			
Environment	Enclosure	IP65 ※1		
	Ambient Temp. Range	Operation : 0 ~ 50 °C, storage : -10 ~ 60 °C (No condensation or freezing)		
	Ambient Humidity Range	Operation / Storage : 35 ~ 85 % RH (No condensation)		
	Vibration	Total amplitude 1.5 mm or 10 G, 10 Hz ~ 55 Hz ~ 10 Hz scan for 1 minute, 2 hours each direction of X, Y and Z		
	Shock	100 m/s ² (10 G), 3 times each in direction of X, Y and Z		
Temperature Characteristic	± 2 % F.S. of detected pressure (25 °C) at temp. (Range of 0 ~ 50 °C)			
Port Size	F1 : R1/8", M5 ; F2 : NPT1/8", #10-32 UNF ; F3 : G1/8" (BSPP), M5 F4 : R1/4", M5 ; F5 : NPT1/4", #10-32 UNF ; F6 : G1/4" (BSPP), M5			
Weight	Approx. 40 g			

NOTE

※1 : Air tube must be installed to maintain IP65.

Ordering Information

K P 6 0 P - **F 1**

Pressure Range

V : Vacuum (10 ~ -101 kPa)
P : Positive (-0.100 ~ 1.000 MPa)

Back Light

Blank : Back light unavailable
L : Back light available

Pressure Port

F1 : R1/8", M5
F2 : NPT1/8", #10-32 UNF
F3 : G1/8" (BSPP), M5
F4 : R1/4", M5
F5 : NPT1/4", #10-32 UNF
F6 : G1/4" (BSPP), M5

Optional Parts

BT-5 : Mounting bracket PA-C : Panel adapter
BT-6 : Mounting bracket PA-D : Panel adapter + Front protective lid

Optional Parts

■ Mounting Bracket : BT-5 / BT-6 ■ Panel Adapter : PA-C ■ Panel adapter + Front protective lid : PA-D



Panel Description

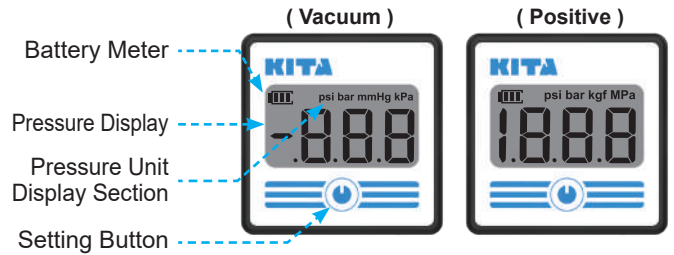

Dimensions

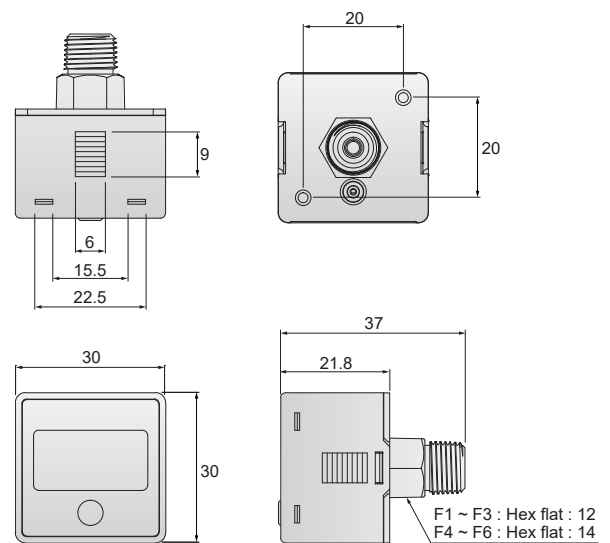

Optional Parts Dimensions

1 Mounting Bracket

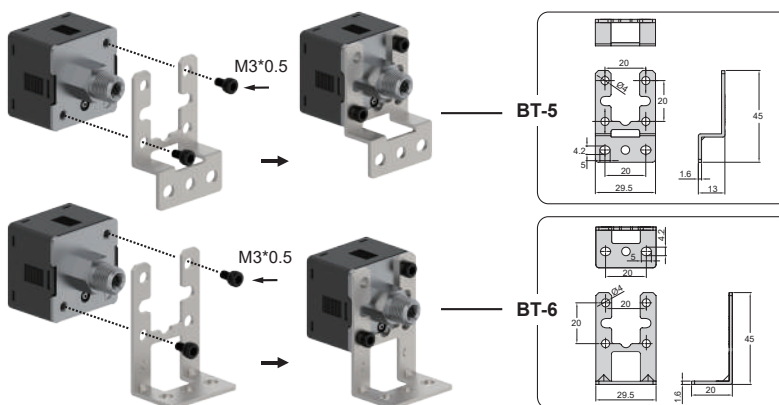

3 IP65 Protector

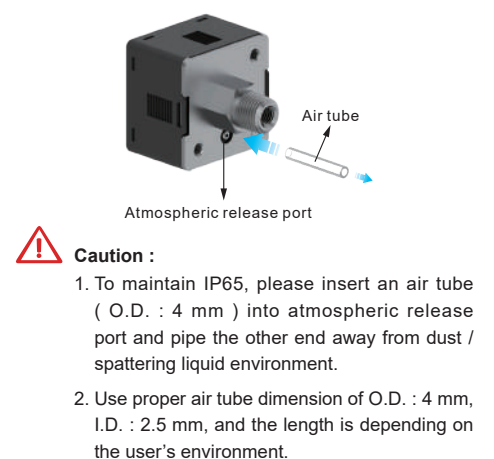

2 Panel Mount Adapter + Front Protective Lid

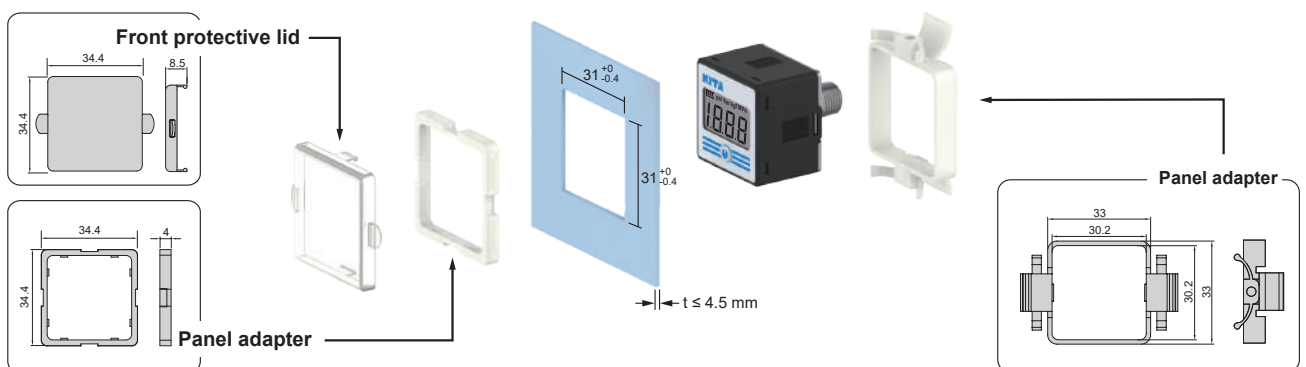

Unit : mm

KP61 SERIES

Pressure Gauge

Features

- Digital pressure gauge
- Setting pressure range :
Vacuum (10 ~ -101 kPa)
Positive (-0.100 ~ 1.000 MPa)
- Selectable pressure unit :
kPa 、 MPa 、 kgf / cm² 、 bar 、 psi
- IP65 enclosure

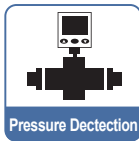

Specifications

MODEL	KP61V		KP61P	
	Vacuum		Positive	
	1.000 MPa			
	0			
	-101 kPa			
Rated Pressure Range	0 ~ -101 kPa		0.000 ~ 1.000 MPa	
Display Pressure Range	10 ~ -101 kPa		-0.100 ~ 1.000 MPa	
Withstand Pressure	300 kPa		1.5 MPa	
Applicable Fluid	Filtered air, Non-corrosive / Non-flammable gas			
Pressure Resolution	kPa	1	-	
	MPa	-	0.001	
	kgf / cm ²	0.01	0.01	
	bar	0.01	0.01	
	psi	0.1	0.1	
Power Supply Voltage	12 ~ 28 V DC ± 10 %, Ripple (P-P) ≤ 10 %			
Current Consumption	10 mA			
Sampling Rate	2 Hz (2 times / sec.)			
Repeatability	± 1 % F.S. ± 1 digit		± 0.2 % F.S. ± 1 digit	
Display	3 ½ digital, 7 segment LCD display (White)			
Indicator Accuracy	± 2 % F.S. ± 1 digit (Ambient temperature : 25 ± 3 °C)			
Environment	Enclosure	IP65 ※1		
	Ambient Temp. Range	Operation : 0 ~ 50 °C, storage : -10 ~ 60 °C (No condensation or freezing)		
	Ambient Humidity Range	Operation / Storage : 35 ~ 85 % RH (No condensation)		
	Withstand Voltage	1000 V AC in 1-min (between case and lead wire)		
	Insulation Resistance	≥ 50 MΩ (at 500 V DC, between case and lead wire)		
	Vibration	Total amplitude 1.5 mm or 10 G, 10 Hz ~ 55 Hz ~ 10 Hz scan for 1 minute, 2 hours each direction of X, Y and Z		
Shock	100 m/s ² (10 G), 3 times each in direction of X, Y and Z			
Temperature Characteristic	± 2 % F.S. of detected pressure (25 °C) at temp. (Range of 0 ~ 50 °C)			
Port Size	F1 : R1/8", M5 ; F2 : NPT1/8", #10-32 UNF ; F3 : G1/8" (BSPP), M5			
Lead Wire	Ø2.8 Oil-resistance cable (PVC) - 26 AWG (0.15 mm ²) - 2 cores			
Weight	Approx. 60 g (with 2 meter lead wire) ; Approx. 40 g (with M8 4Pin male connector)			

NOTE

※1 : Air tube must be installed to maintain IP65.

Panel Description

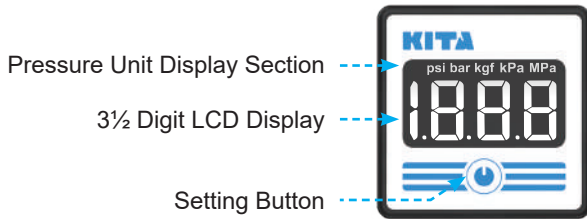

Circuit Wiring Diagram

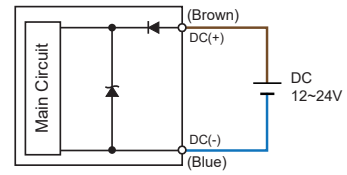

* Pressure display only, no switch output function.

Ordering Information

K P 6 1 P - F 1 -

Pressure Range

V : Vacuum (10 ~ -101 kPa)
P : Positive (-0.100 ~ 1.000 MPa)

Cable Length / Connector

Blank : With 2 meter cable
QD : With M8 4Pin male connector

Optional Parts

BT-5 : Mounting bracket
BT-6 : Mounting bracket
PA-C : Panel adapter
PA-D : Panel adapter + Front protective lid

Pressure Port

F1 : R1/8", M5
F2 : NPT1/8", #10-32 UNF
F3 : G1/8" (BSPP), M5

Dimensions

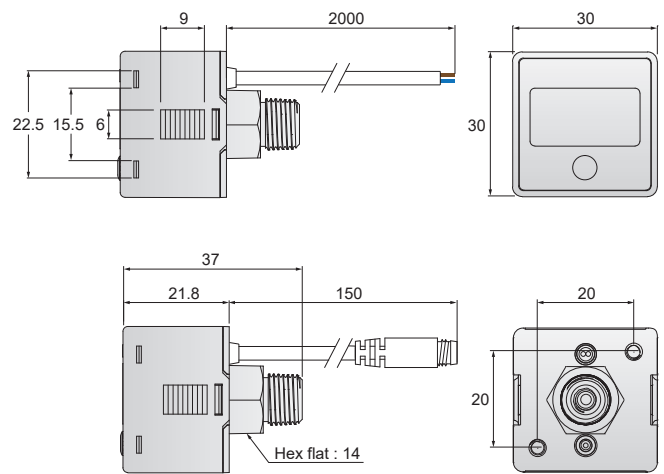

Optional Parts Dimensions

1 Mounting Bracket

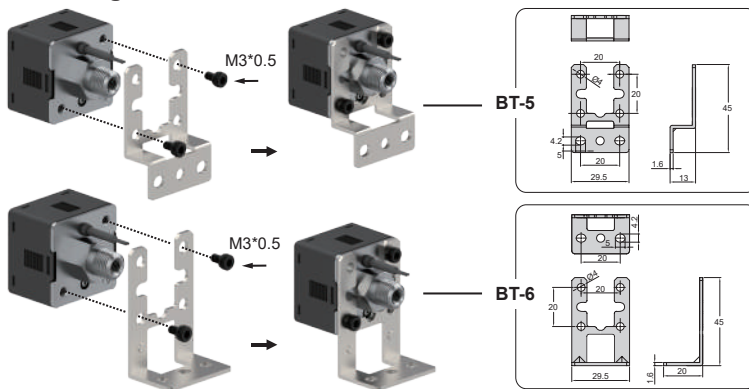

3 IP65 Protector

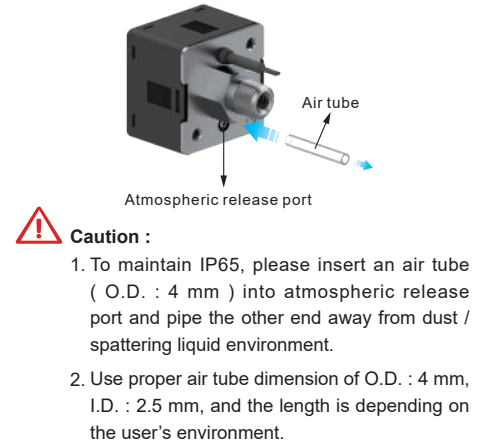

2 Panel Mount Adapter + Front Protective Lid

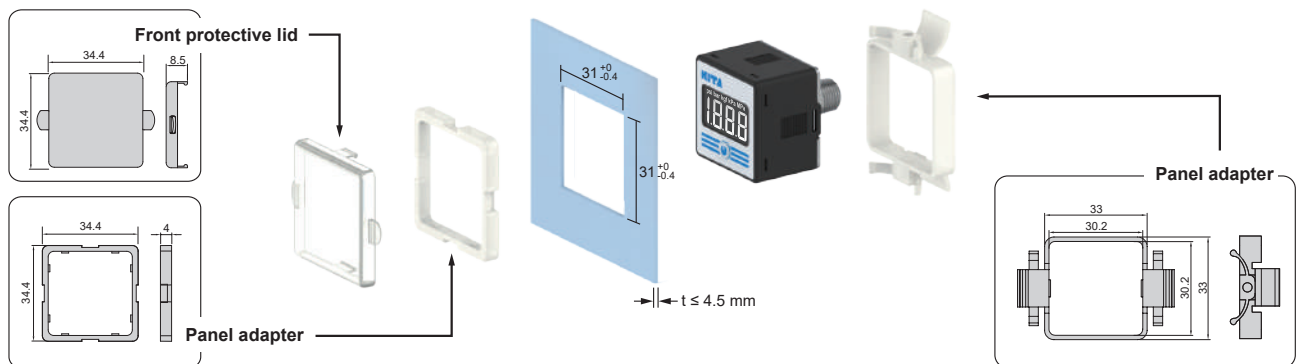

KP70 SERIES

IOT Pressure Sensor

Features

- Smart pressure sensor
- Remote control
- Real-time monitoring
- RS485 Modbus RTU / ASCII
- 4 digits, 7 segment LCD display

RS485 MODBUS CONTROL

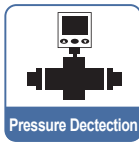
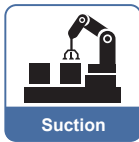

Features Highlight

1 Station Setting Display

- Provide 0 ~ 255 station to set the sensor



ID Number Display

2 Modes Display

- Three modes show on the screen



3 Setting Value Easy Indication

- User can easily observe the setting value from sub-display

Main / Sub-Display

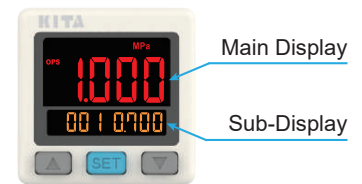

4 Easy Unit Identification

- Unit conversion easy to read

mmHg inHg psi bar kgf/cm² MPa kPa



5 2-Color Main Display

- User selectable color mode, for different conditions use



	SoG	SoR	Grn	REd
ON	Green	Red	Green	Red
OFF	Red	Green	Green	Red

6 OPS Quick Setting

- Sub-display allows changing the parameter directly, reduce setting step by 3/4

Up / Down Quick Setting

Finished Setting



Specifications

MODEL		KP70C	KP70V	KP70P
		Compound	Vacuum	Positive
Rated Pressure Range		-100.0 ~ 100.0 kPa	0.0 ~ -101.3 kPa	0.000 ~ 1.000 MPa
Set Pressure Range		-101.0 ~ 101.0 kPa	10.0 ~ -101.3 kPa	-0.100 ~ 1.000 MPa
Withstand Pressure		500 kPa		1.5 MPa
Fluid		Filtered air, Non-corrosive / Non-flammable gas		
Set Pressure Resolution	kPa	0.1		-
	MPa	-		0.001
	kgf / cm ²	0.001		0.01
	bar	0.001		0.01
	psi	0.01		0.1
	inHg	0.1		-
	mmHg	1		-
Power Supply Voltage		12 ~ 24 V DC ± 10 %, Ripple (P-P) ≤ 10 %		
Current Consumption		≤ 40 mA (with no load)		
Switch Output		1 NPN : open collector 1 output Max. Load Current : 125 mA Max. Supply Voltage : 30 V DC Residual Voltage : ≤ 1.5 V		1 PNP : open collector 1 output Max. Load Current : 125 mA Max. Supply Voltage : 24 V DC Residual Voltage : ≤ 1.5 V
Repeatability		± 0.2 % F.S. ± 1 digit		
Hysteresis	One Point Set Mode	Adjustable ※1		
	Hysteresis Mode			
	Window Comparator Mode			
Response Time		≤ 2.5 ms (Chattering-proof function : 25 ms, 100 ms, 250 ms, 500 ms, 1000 ms, 1500 ms, 2000 ms and 5000 ms selectable)		
Output Short Circuit Protection		Yes		
Display		4 digital, 7 segment LCD display (Red / Green / Orange) (Sampling rate : 0.2, 0.5, 1 seconds / time selectable)		
Indicator Accuracy		± 2 % F.S. ± 1 digit (Ambient temperature : 25 ± 3 °C)		
Switch on Indicator		Orange Indicator 1 : OUT		
Environment	Enclosure	IP40		
	Ambient Temp. Range	Operation : 0 ~ 50 °C, Storage : -10 ~ 60 °C (No condensation or freezing)		
	Ambient Humidity Range	Operation / Storage : 35 ~ 85 % RH (No condensation)		
	Withstand Voltage	1000 V AC in 1-min (between case and lead wire)		
	Insulation Resistance	≥ 50 MΩ (at 500 V DC, between case and lead wire)		
	Vibration	Total amplitude 1.5 mm or 10 G, 10 Hz ~ 55 Hz ~ 10 Hz scan for 1 minute, 2 hours each direction of X, Y and Z		
	Shock	100 m/s ² (10 G), 3 times each in direction of X, Y and Z		
Temperature Characteristic		± 2.5 % F.S. of detected pressure (25 °C) at temp. (Range of 0 ~ 50 °C)		
Communication Interface		RS485		
Port Size		F1 : R1/8", M5 ; F2 : NPT1/8", #10-32 UNF ; F3 : G1/8" (BSPP), M5		
Lead Wire		Ø4 Oil-resistance cable (PVC) - 26 AWG (0.15 mm ²) - 5 cores		
Weight (with 2 meter lead wire)		Approx. 80 g		

NOTE

※1 : Hysteresis value is adjustable within 1 ~ 8 digits for one point set mode and window comparator mode.

KP70 SERIES

IOT Pressure Sensor

Panel Description

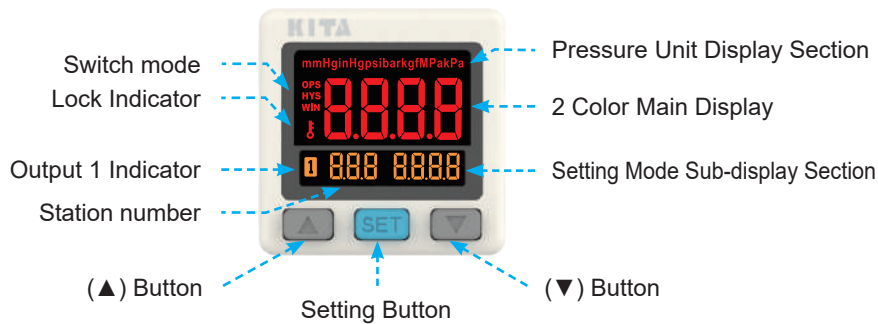

Installation Precautions

- When mounting, always use the wrench on the metallic area near the pressure port. Never apply a wrench to the plastic body, it will damage the sensor.
- Over tightening may cause damage to the port thread, mounting bracket and pressure sensor. Under tightening may result loosen or leakage.
- Apply air pressure and power after installation, make necessary adjustments and inspect any possible signs of leakage to ensure proper installation.

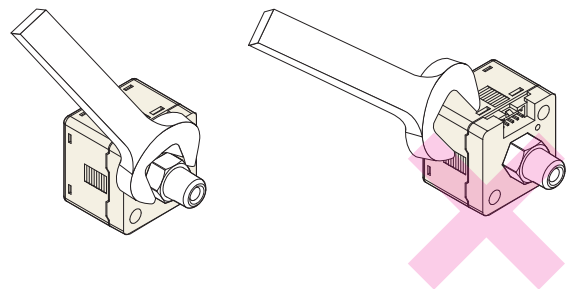

Output Circuit Wiring Diagrams

KP70 □ - 02 - □

NPN output + RS485

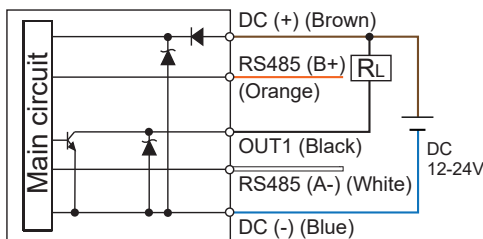

KP70 □ - 04 - □

PNP output + RS485

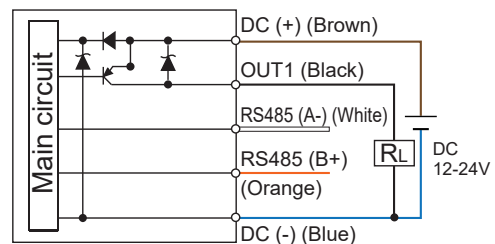

* Procedure to wiring RS485 products : To prevent product damage due to short circuit , MUST do RS485 line connection BEFORE power line connection.

Ordering Information

K P 7 0 C - 0 2 - F 1

Pressure Range

C : Compound (-101.0 ~ 101.0 kPa)
 V : Vacuum (10.0 ~ -101.3 kPa)
 P : Positive (-0.100 ~ 1.000 MPa)

Output Specifications

02 : 1 NPN output + RS485
 04 : 1 PNP output + RS485

Pressure Port

F1 : R1/8", M5
 F2 : NPT1/8", #10-32UNF
 F3 : G1/8" (BSPP), M5

Optional Parts

BT-12 : Mounting bracket
 BT-13 : Mounting bracket
 PA-C : Panel adapter
 PA-D : Panel adapter + Front protective lid

Optional Parts

■ Mounting Bracket : BT-12 / BT-13

■ Panel Adapter : PA-C

■ Panel Adapter + Front Protective Lid : PA-D



Dimensions

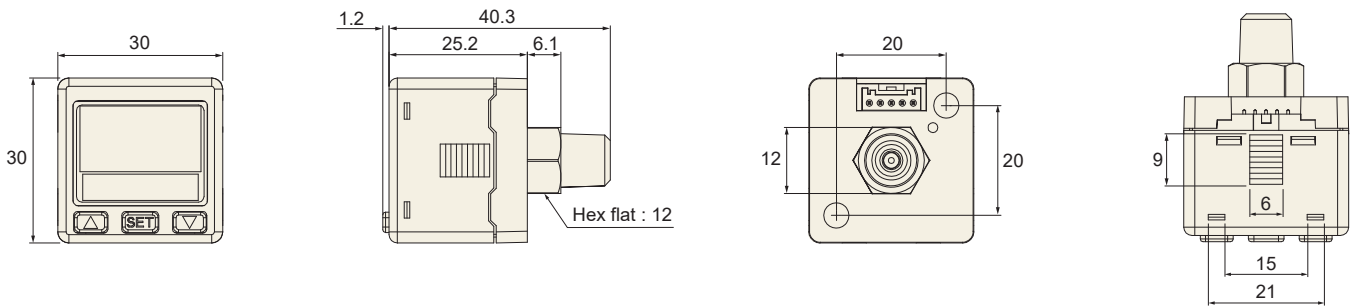

Optional Parts Dimensions

1 Mounting Bracket

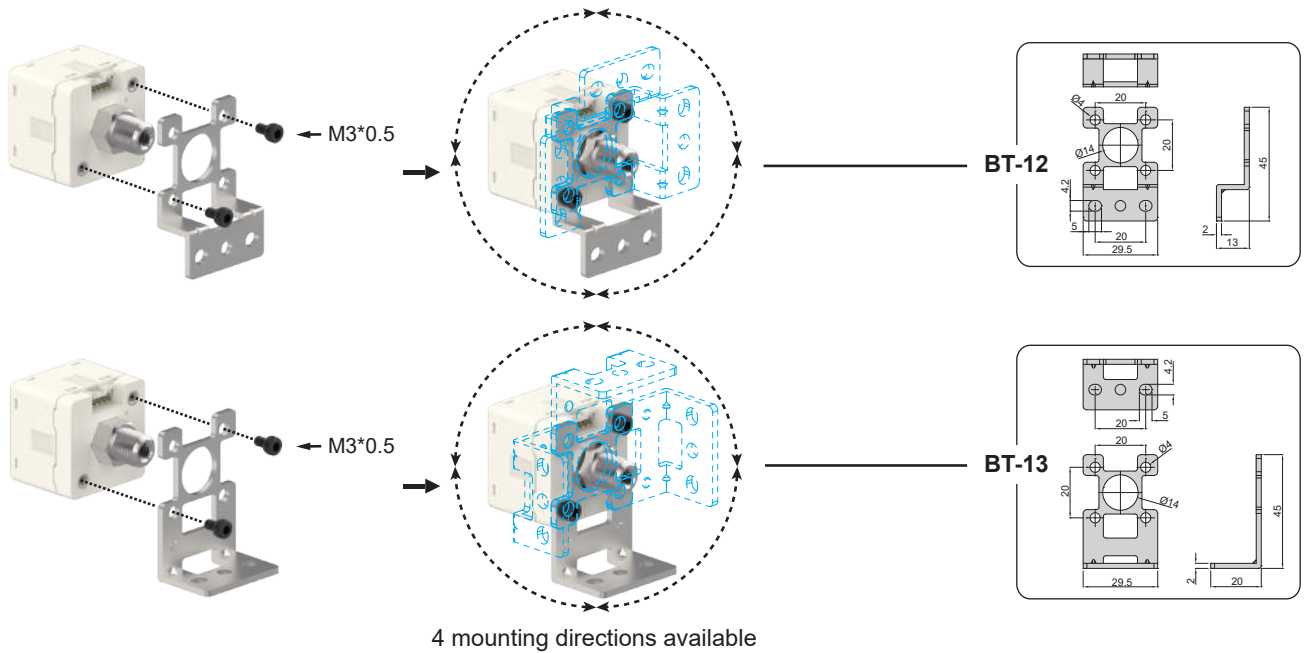

2 Panel Mount Adapter + Front Protective Lid

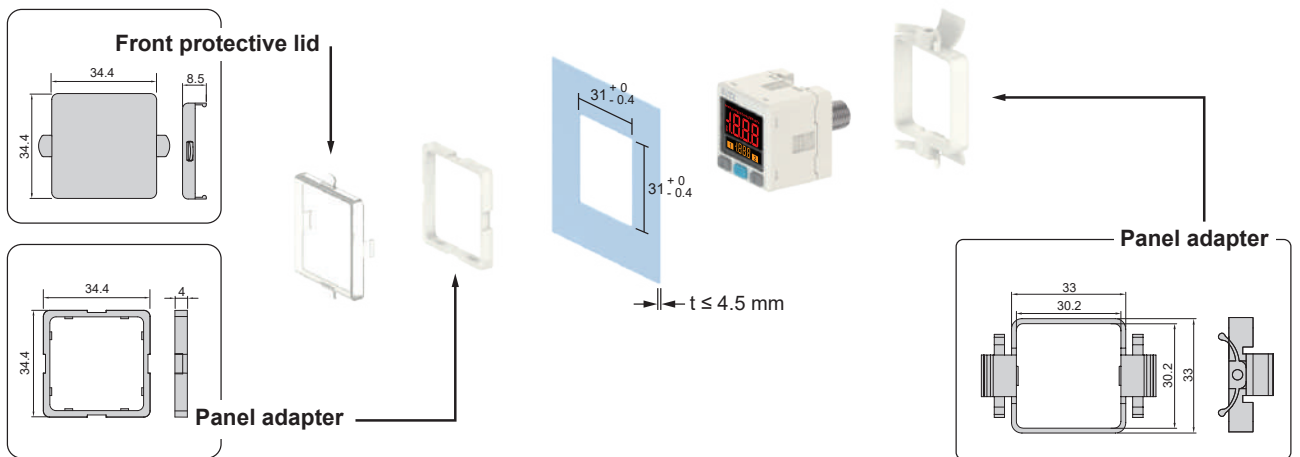

Unit : mm

KP75 SERIES

IOT Pneumatic · Hydraulic Pressure Sensor (Multi-Medium)

Features

- Corrosive fluid or gas available (in the pipeline)
- Sensor parts & Fitting parts : SUS316L
- 2-color digital LCD display
- Remote control / Real-time monitoring
- RS485 Modbus RTU / ASCII
- 3½ digit, 7 segment LCD display
- IP65 enclosure

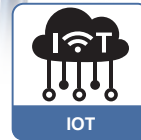
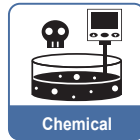
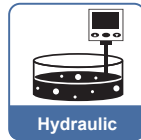
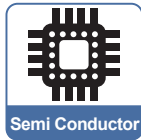

RS485 MODBUS CONTROL

Features Highlight

1 Quick Installation

- Save installation time
- Easy removal

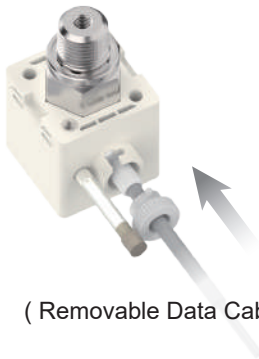

2 Easy Unit Identification

- Unit conversion easy to read

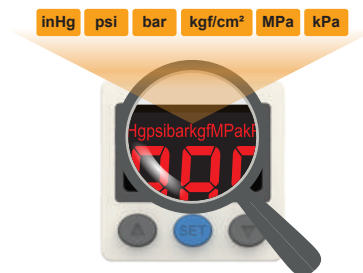

3 Applicable for Corrosive Fluid or Gas

- Sensor parts & Fitting parts are SUS316L, applicable for corrosive fluid or gas equipment

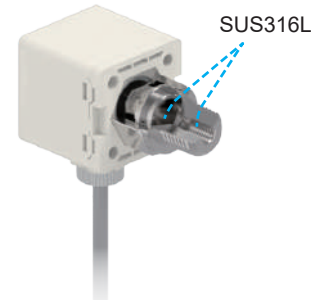

4 2-Color Display

- User selectable color mode, for different conditions use



	SoG	SoR	Grn	rEd
ON	Green	Red	Green	Red
OFF	Red	Green	Green	Red

5 IP65 Compliance



Specifications

MODEL	KP75C	KP75P	KP75H02
	Compound	Positive	High
Rated Pressure Range	-100.0 ~ 100.0 kPa	0.000 ~ 1.000 MPa	0.000 ~ 2.00 MPa
Set Pressure Range	-101.0 ~ 101.0 kPa	-0.100 ~ 1.000 MPa	-0.100 ~ 2.00 MPa
Withstand Pressure	300 kPa	3 MPa	
Fluid	Fluid or air that will not corrode SUS316L		
Sealed Liquid	Silicon oil		
Set Pressure Resolution	kPa	0.1	-
	MPa	-	0.001
	kgf / cm ²	0.001	0.01
	bar	0.001	0.01
	psi	0.01	0.1
	inHg	0.1	-
Power Supply Voltage	12 ~ 24 V DC ± 10 %, Ripple (P-P) ≤ 10 %		
Current Consumption	≤ 40 mA (with no load)		
Switch Output	1 NPN or 1 PNP open collector Max. Load Current : 125 mA Max. Supply Voltage : 1 NPN 30 V DC, 1 PNP 24 V DC Residual Voltage : ≤ 1.5 V		
Repeatability	± 0.3 % F.S. ± 1 digit		
Response Time	≤ 2.5 ms (Chattering-proof function : 25 ms, 100 ms, 250 ms, 500 ms, 1000 ms and 1500 ms selections)		
Output Short Circuit Protection	Yes		
Display	3 ½ digital, 7 segment LCD display (Red / Green / Orange) (Sampling rate : 5 times / sec.)		
Indicator Accuracy	± 2 % F.S. ± 1 digit (Ambient temperature : 25 ± 3 °C)		
Switch on Indicator	Orange Indicator 1 : OUT		
Environment	Enclosure	IP65 ※1	
	Ambient Temp. Range	Operation : 0 ~ 50 °C, Storage : -10 ~ 60 °C (No condensation or freezing)	
	Ambient Humidity Range	35 ~ 85 % RH (No condensation)	
	Withstand Voltage	250 V AC in 1-min (between case and lead wire)	
	Insulation Resistance	≥ 50 MΩ (at 500 V DC, between case and lead wire)	
	Vibration	Total amplitude 1.5 mm or 10 G, 10 Hz ~ 55 Hz ~ 10 Hz scan for 1 minute, 2 hours each direction of X, Y and Z	
Shock	100 m/s ² (10 G) , 3 times each in direction of X, Y and Z		
Temperature Characteristic	± 3 % F.S. of detected pressure (25 °C) at temp. (Range of 0 ~ 50 °C)		
Communication Interface	RS485		
Port Size ※2	F1 : R1/4", M5 ; F2 : NPT1/4", #10-32UNF ; F3 : G1/4" (BSPP), M5		
Lead Wire	Ø4 Oil-resistance cable (PVC) - 26 AWG (0.15 mm ²) - 5 cores		
Weight (with 2 Meter Lead Wire)	Approx. 110 g (Rear ported) ; Approx. 150 g (Bottom ported)		

NOTE

※1 : Dustproof protector must be installed to maintain IP65.

※2 : G port O-Ring material is NBR. if any special request, please contact KITA.

KP75 SERIES

IOT Pneumatic · Hydraulic Pressure Sensor (Multi-Medium)

Panel Description

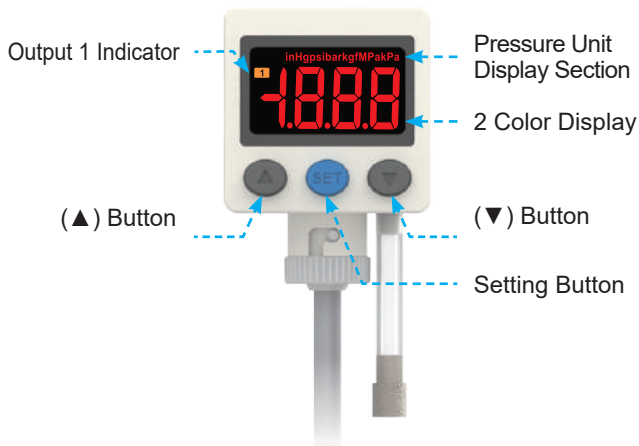

Installation Precautions

- When mounting, always use the wrench on the metallic area near the pressure port. Never apply a wrench to the plastic body, it will damage the sensor.
- Over tightening may cause damage to the port thread, mounting bracket and pressure sensor. Under tightening may result loosen or leakage.
- Apply air pressure and power after installation, make necessary adjustments and inspect any possible signs of leakage to ensure proper installation.

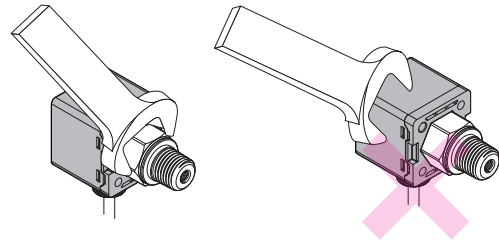

Circuit Wiring Diagrams

KP75□ - 02 - □
NPN output + RS485

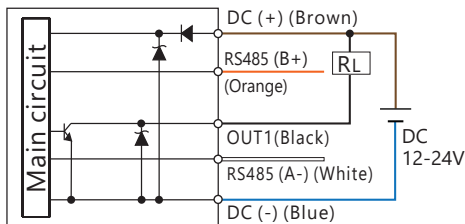

KP75□ - 04 - □
PNP output + RS485

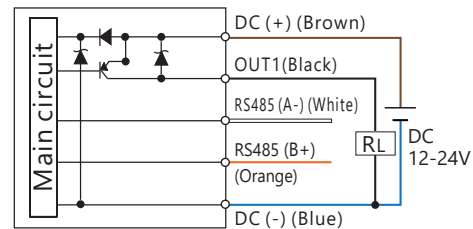

* Procedure to wiring RS485 products : To prevent product damage due to short circuit , MUST do RS485 line connection BEFORE power line connection.

Ordering Information

K P 7 5 C - 0 2 - F 1 □

Pressure Range

C : Compound (-101.0 ~ 101.0 kPa)
P : Positive (-0.100 ~ 1.000 MPa)
H02 : High (-0.100 ~ 2.00 MPa)

Output Specifications

02 : NPN output + RS485
04 : PNP output + RS485

Pressure Port

F1 : R1/4", M5
F2 : NPT1/4", #10-32UNF
F3 : G1/4" (BSPP) , M5

Piping Direction

Blank : Rear ported
L : Bottom ported

Optional Parts

BT-10 : Mounting bracket
BT-11 : Mounting bracket
PA-E : Panel adapter
PA-F : Panel adapter + Front protective lid

I-0360 : Snubber (for Pressure Port F1 & F3)
I-0379 : Snubber (for Pressure Port F2)
*KP75P & KP75H02 suggest to select a snubber

Optional Parts

■ Mounting Bracket :
BT-10 / BT-11

■ Panel Adapter : PA-E

■ Panel adapter + Front protective lid :
PA-F

■ Snubber

I-0360 : for Pressure Port F1 & F3
I-0379 : for Pressure Port F2



Removable Snubber Installed

- Pressure port equipped with snubber can avoid damage caused by sudden pressure surge of water or oil, improve product durability.

* When snubber is clogged with contaminants, please use a flat head screwdriver to remove the snubber, clean and reinstall.

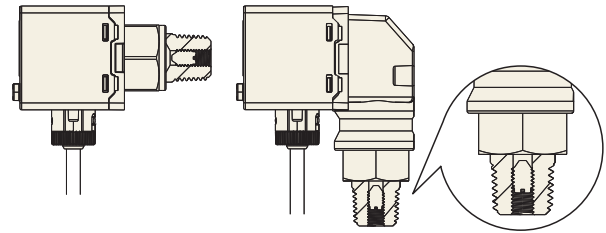

Dimensions

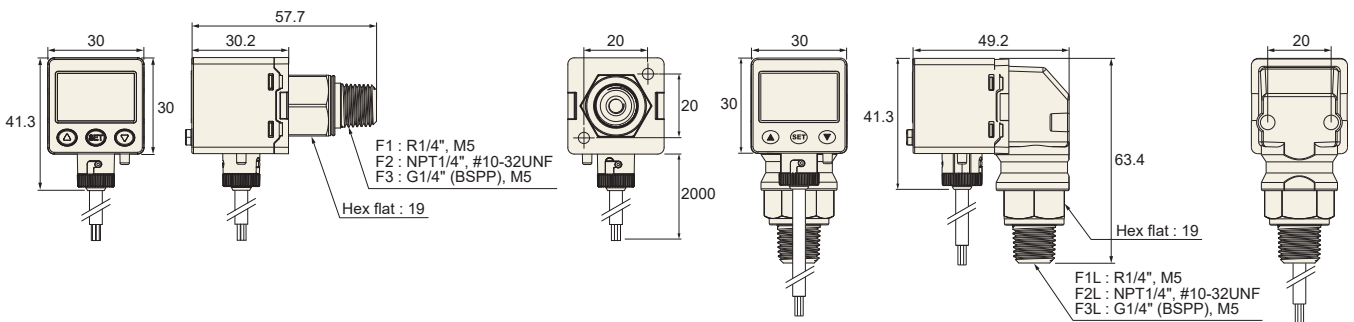

Optional Parts Dimensions

1 Mounting Bracket

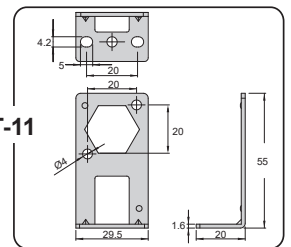
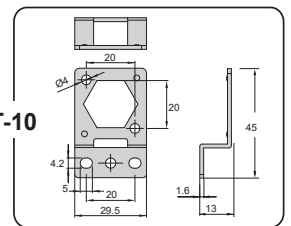
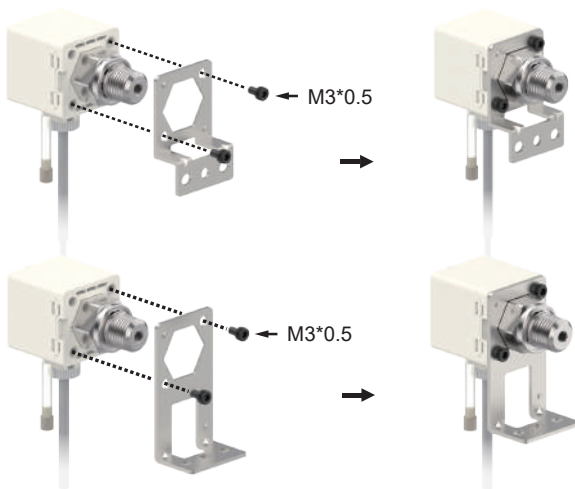

2 Panel Mount Adapter + Front Protective Lid

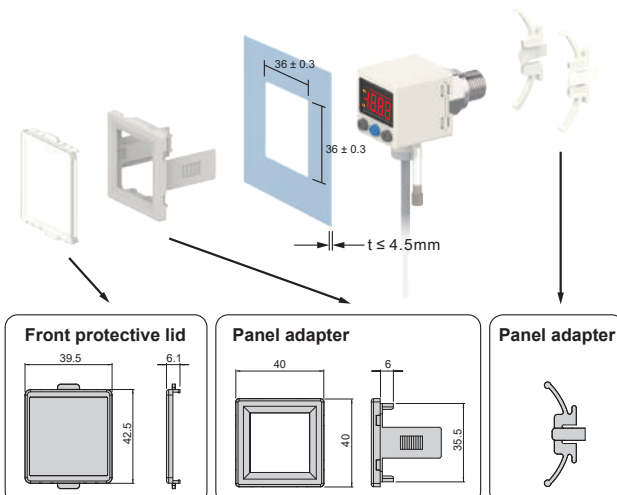

3 IP65 Protector

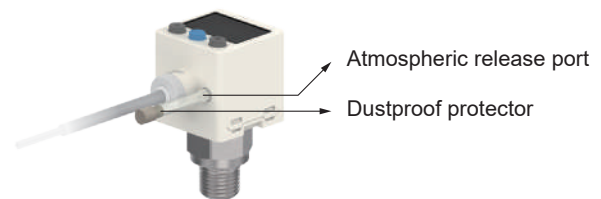

Caution :

This device must be installed to maintain IP65 (Dust and splash proof) enclosure rating.

Unit : mm

KP90 SERIES

Slim Pressure Sensor

Features

- 2 output & analog output (1 ~ 5 V)
- 10 mm width with compact size
- Key-lock function
- Selectable pressure unit :
kPa 、 MPa 、 kgf / cm² 、 bar 、 psi 、 inHg 、 mmHg

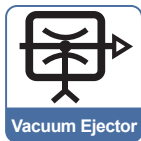
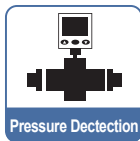
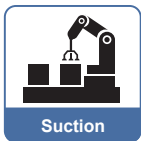

Features Highlight

1 Selectable Pressure Unit

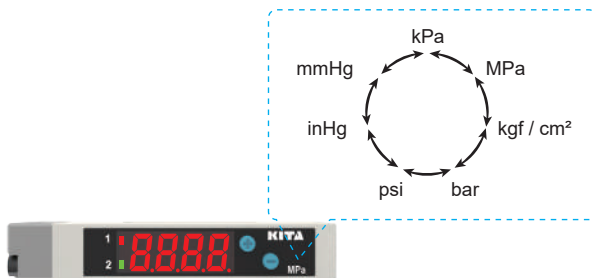

2 Key-lock Function

- Key-lock mode to prevent unauthorized adjustments Press ⊕ and ⊖ button at the same time for 3 sec.

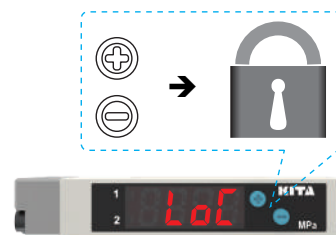

Key-lock function

3 Analog Output

- Output range 1 to 5 V, proportional to the pressure range

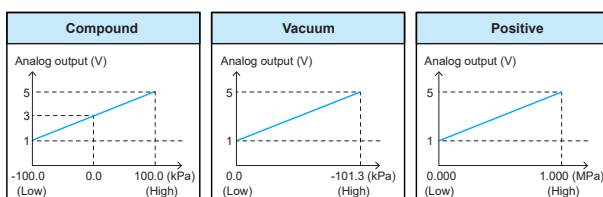

4 Compact Size

KP90



VS.

KP30



Specifications

MODEL	KP90C		KP90V	KP90P
	Compound		Vacuum	Positive
Rated Pressure Range	-100.0 ~ 100.0 kPa		0.0 ~ -101.3 kPa	0.000 ~ 1.000 MPa
Set Pressure Range	-101.0 ~ 101.0 kPa		10.0 ~ -101.3 kPa	-0.100 ~ 1.000 MPa
Withstand Pressure	500 kPa			1.5 MPa
Fluid	Filtered Air, Non-corrosive / Non-flammable gas			
Set Pressure Resolution	kPa	0.1		-
	MPa	-		0.001
	kgf / cm ²	0.001		0.01
	bar	0.001		0.01
	psi	0.01		0.1
	inHg	0.1		-
	mmHg	1		-
Power Supply Voltage	12 ~ 24 V DC ± 10 %, Ripple (P-P) ≤ 10 %			
Current Consumption	≤ 40 mA (with no load)			
Switch Output	2 NPN : open collector 2 outputs Max. Load Current : 125 mA Max. Supply Voltage : 30 V DC Residual Voltage : ≤ 1.5 V		2 PNP : open collector 2 outputs Max. Load Current : 125 mA Max. Supply Voltage : 24 V DC Residual Voltage : ≤ 1.5 V	
Repeatability	± 0.2 % F.S. ± 1 digit			
Hysteresis	Hysteresis Mode	Adjustable		
	Window Comparator Mode	Fixed (3 digits)		
Response Time	≤ 2.5 ms (Chattering-proof function : 25 ms, 100 ms, 250 ms, 500 ms, 1000 ms and 1500 ms selectable)			
Output Short Circuit Protection	Yes			
Display	4 digit, 7 segment LED display (Red) (Sampling rate : 5 times / sec.)			
Indicator Accuracy	± 2 % F.S. ± 1 digit (Ambient temperature : 25 ± 3 °C)			
Switch on Indicator	Indicator Red : OUT1 & Indicator Green : OUT2			
Analog Output (Voltage Output)	Output Voltage : 1 ~ 5 V ± 2.5 % F.S. (within rated pressure range) Linearity : ± 1 % F.S. Output Impedance : about 1 kΩ			
Environment	Enclosure	IP40		
	Ambient Temp. Range	Operation : 0 ~ 50 °C, Storage : -10 ~ 60 °C (No condensation or freezing)		
	Ambient Humidity Range	Operation / Storage : 35 ~ 85 % RH (No condensation)		
	Withstand Voltage	1000 V AC in 1-min (between case and lead wire)		
	Insulation Resistance	≥ 50 MΩ (at 500 V DC, between case and lead wire)		
	Vibration	Total amplitude 1.5 mm or 10 G, 10 Hz ~ 150 Hz ~ 10 Hz scan for 1 minute, 2 hours each direction of X, Y and Z		
	Shock	980 m/s ² (100 G), 3 times each in direction of X, Y and Z		
Temperature Characteristic	± 2 % F.S. of detected pressure (25 °C) at temp. (Range of 0 ~ 50 °C)			
Port Size	M5			
Lead Wire	Ø3.8 Oil-resistance cable (PVC) - 26 AWG (0.15 mm ²) - 5 cores			
Weight (with 2 meter lead wire)	Approx. 53 g			

Panel Description



Output Circuit Wiring Diagrams

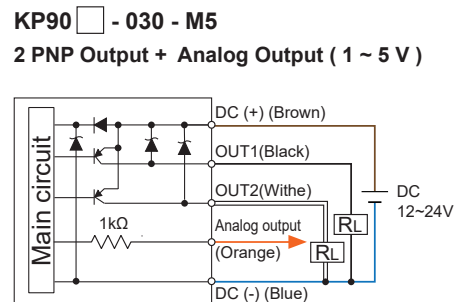
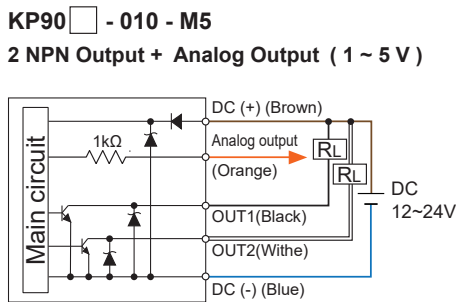

Ordering Information

K P 9 0 P - 0 1 0 - M 5

Pressure Range

C : Compound (-101.0 ~ 101.0 kPa)
 V : Vacuum (10.0 ~ -101.3 kPa)
 P : Positive (-0.100 ~ 1.000 MPa)

Output Specification

010 : 2 NPN output & Analog output (1 ~ 5 V)
 030 : 2 PNP output & Analog output (1 ~ 5 V)

Installation Precautions

- When mounting, always use the wrench on the metallic area near the pressure port. Never apply a wrench to the plastic body, it will damage the sensor.
- Do not use a sharp tool to insert the pressure inlet to avoid damaging the sensor chip.
- Do not use the product in an environment that is exposed to the splash of water or dust. Otherwise failure or malfunction may occur.

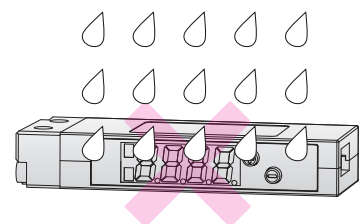
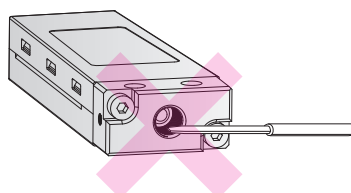
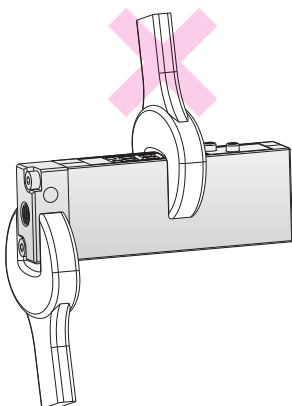

Dimensions

KP90□ - □ - M5

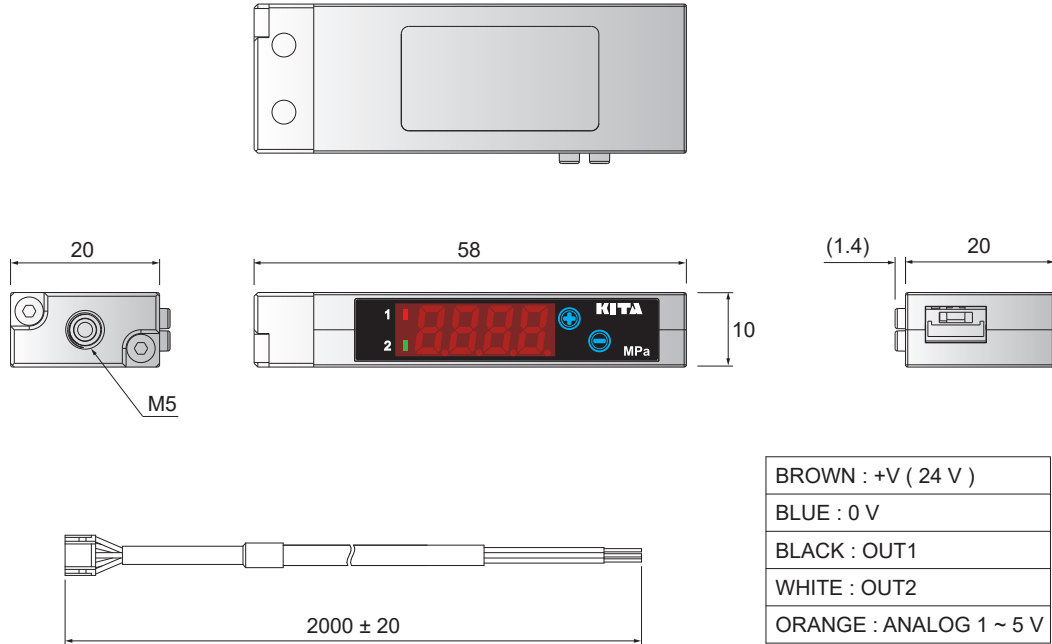

Unit : mm

Features

- 3-color digital LCD display
- Selectable pressure unit : kPa 、 MPa 、 kgf / cm² 、 bar 、 psi 、 inHg 、 mmHg
- Dual LCD display allows setting value to be displayed
- Key-lock indicator
- Analog output : 1 ~ 5 V or 4 ~ 20 mA
- Sensor input : 1 ~ 5 V or 4 ~ 20 mA
- 12 pressure ranges for transducer

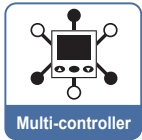
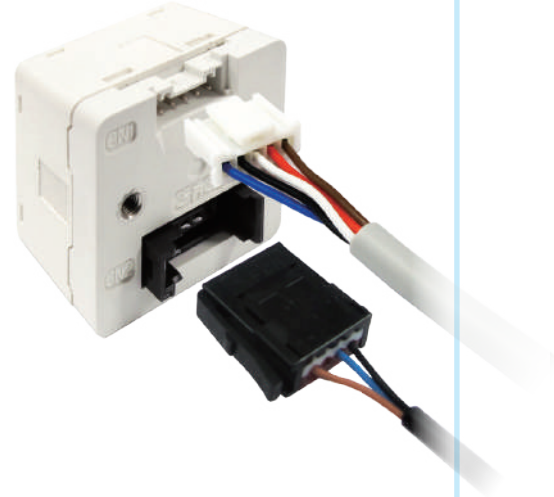

Features Highlight

1 3-Color Digital LCD Display

- Main display color change with output status

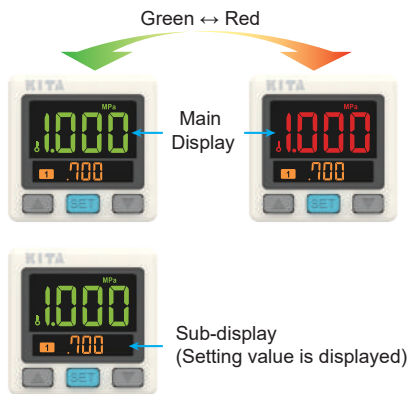

2 Selectable Pressure Unit

- Unit conversion easy to read

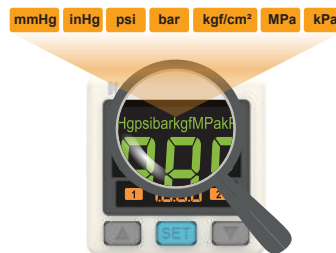

3 Save Installation Space

Panel opening for multiple pressure controller



Calculation factor (A) = (34.4 x n) - 3.4
n = number of controller

Actual dimension after installation



4 Key-lock Function

- Key-lock icon is shown on the display when the function is enabled



5 12 Pressure Ranges for Transducer

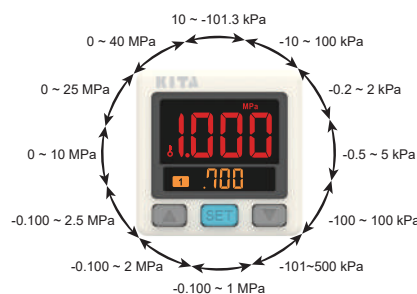

6 Analog Output / Sensor Input

- Current output or voltage output is available

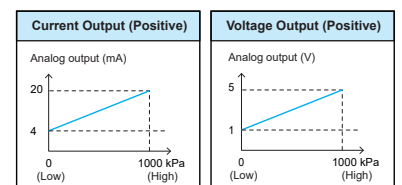

Specifications

MODEL		KP400												
Sensor Type		S - 0	S - 1	S - 2	S - 3	S - 4	S - 5	S - 6	S - 7	S - 8	S - 9	S - 10	S - 11	S - 12
Rated Pressure Range		Self-Setting ※1	0 ~ -101.3 kPa	0 ~ 100 kPa	0 ~ 2 kPa	0 ~ 5 kPa	-100 ~ 100 kPa	-101 ~ 500 kPa	0 ~ 1 MPa	0 ~ 2 MPa	0 ~ 2.5 MPa	0 ~ 10 MPa	0 ~ 25 MPa	0 ~ 40 MPa
Set Pressure Range			10 ~ -101.3 kPa	-10 ~ 100 kPa	-0.2 ~ 2 kPa	-0.5 ~ 5 kPa	-100 ~ 100 kPa	-101 ~ 500 kPa	-0.100 ~ 1 MPa	-0.100 ~ 2 MPa	-0.100 ~ 2.5 MPa	0 ~ 10 MPa	0 ~ 25 MPa	0 ~ 40 MPa
Set Pressure Range (Auto-Shift Input)		-	101.3 ~ -101.3 kPa	-100 ~ 100 kPa	-2 ~ 2 kPa	-5 ~ 5 kPa	-100 ~ 100 kPa	-500 ~ 500 kPa	-1 ~ 1 MPa	-2 ~ 2 MPa	-2.5 ~ 2.5 MPa	-10 ~ 10 MPa	-25 ~ 25 MPa	-40 ~ 40 MPa
Set Pressure Resolution	kPa	Self-Setting	0.1	0.1	0.01	0.01	0.1	1	-	-	-	-	-	-
	MPa		-	-	-	-	-	0.001	0.01	0.01	0.01	0.1	0.1	0.1
	kgf / cm ²		0.001	0.001	-	-	0.001	0.01	0.01	0.1	0.1	0.1	1	1
	bar		0.001	0.001	-	-	0.001	0.01	0.01	0.1	0.1	0.1	1	1
	psi		0.01	0.01	-	-	0.01	0.1	0.1	1	1	1	1 ※2	1 ※2
	inHg		0.1	-	-	-	0.1	-	-	-	-	-	-	-
	mmHg		1	-	0.1	0.1	1	-	-	-	-	-	-	-
	---		-	-	-	-	-	-	-	-	-	-	-	-
Power Supply Voltage		12 ~ 24 V DC ± 10 %, Ripple (P-P) ≤ 10 %												
Current Consumption		≤ 40 mA (with no load)												
Sensor Input		1 ~ 5 V or 4 ~ 20 mA												
Switch Output		2 NPN : open collector 2 outputs Max. Load Current : 125 mA Max. Supply Voltage : 30 V DC Residual Voltage : ≤ 1.5 V						2 PNP : open collector 2 outputs Max. Load Current : 125 mA Max. Supply Voltage : 24 V DC Residual Voltage : ≤ 1.5 V						
Repeatability		± 0.1 % F.S. ± 1 digit												
Hysteresis	One Point Set Mode	Adjustable ※3												
	Hysteresis Mode													
	Window Comparator Mode													
Response Time		≤ 2.5 ms (Chattering-proof function : 25 ms, 100 ms, 250 ms, 500 ms, 1000 ms and 1500 ms selectable)												
Output Short Circuit Protection		Yes												
Display		3 ½ digital, 7 segment LCD display (Red / Green / Orange) (Sampling rate : 5 times / sec.)												
Indicator Accuracy		± 1 % F.S. ± 1 digit (Ambient temperature : 25 ± 3 °C)												
Switch on Indicator		Orange Indicator 1 : OUT1 & Orange Indicator 2 : OUT2												
Analog output (Voltage Output) ※4		Output Voltage : 1 ~ 5 V ± 2 % F.S. (within rated pressure range) Linearity : ± 1 % F.S. Output Impedance : about 1 kΩ												
Analog output (Current Output) ※5		Output Current : 4 ~ 20 mA ± 2 % F.S. (within rated pressure range) Linearity : ± 1 % F.S. Max. Load Impedance : 300 Ω at power supply of 12 V, 600 Ω at power supply of 24 V Min. Load Impedance : 50 Ω												
Environment	Enclosure	IP40												
	Ambient Temp. Range	Operation : 0 ~ 50 °C, storage : -10 ~ 60 °C (No condensation or freezing)												
	Ambient Humidity Range	Operation / Storage : 35 ~ 85 % RH (No condensation)												
	Withstand Voltage	1000 V AC in 1-min (between case and lead wire)												
	Insulation Resistance	≥ 50 MΩ (at 500 V DC, between case and lead wire)												
	Vibration	Total amplitude 1.5 mm or 10 G, 10 Hz ~ 55 Hz ~ 10 Hz scan for 1 minute, 2 hours each direction of X, Y and Z												
Shock		100 m/s ² (10 G), 3 times each in direction of X, Y and Z												
Temperature Characteristic		± 0.5 % F.S. of detected pressure (25 °C) at temp. (Range of 0 ~ 50 °C)												
Lead Wire		Ø4 Oil-resistance cable (PVC) - 26 AWG (0.15 mm ²) - 5 cores												
Weight (with 2 meter lead wire)		Approx. 67 g												

NOTE

- ※1 : S-0 : Set the sensor range (1999 ~ -1999) by self. The decimal place can be adjusted.
- ※2 : If set pressure unit is psi, the value requires to ten multiply by display value.
- ※3 : Hysteresis value is adjustable within 1 ~ 8 digits for one point set mode and window comparator mode.
- ※4 : If analog voltage output is selected, the analog current output cannot be selected at the same time.
- ※5 : If analog current output is selected, the analog voltage output cannot be selected at the same time.

Panel Description

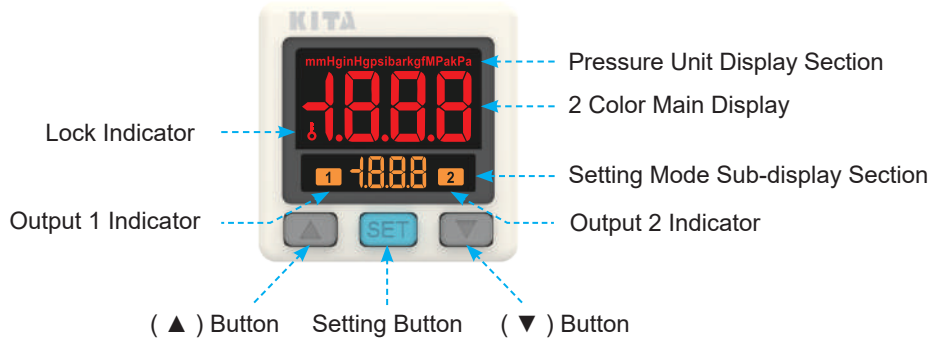

Output Circuit Wiring Diagrams

KP4□0 - 010

2 NPN + Analog Output (1 ~ 5 V)

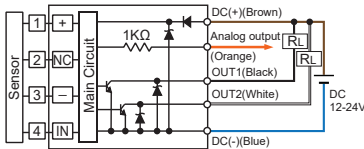

KP4□0 - 030

2 PNP + Analog Output (1 ~ 5 V)

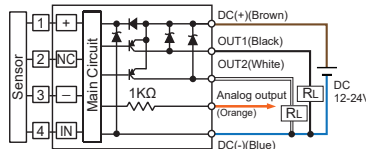

KP4□0 - 05

2 NPN Output + Auto-shift input

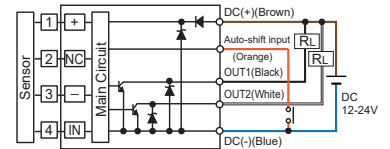

KP4□0 - 011

2 NPN + Analog Output (4 ~ 20 mA)

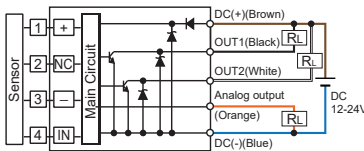

KP4□0 - 031

2 PNP + Analog Output (4 ~ 20 mA)

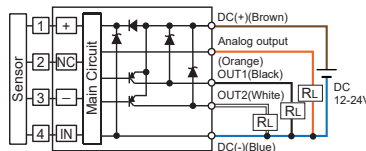

KP4□0 - 07

2 PNP Output + Auto-shift input

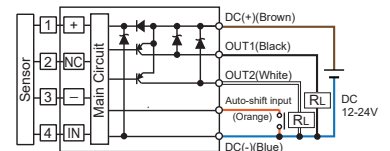

Ordering Information

K P 4 1 0 - 0 1 0

Input Specifications

- 1 : Voltage input
- 2 : Current input

Output Channel

- 0 : 1 Channel

Input / Output Specifications

- 010 : 2 NPN outputs & Analog output (1 ~ 5 V)
- 011 : 2 NPN outputs & Analog output (4 ~ 20 mA)
- 030 : 2 PNP outputs & Analog output (1 ~ 5 V)
- 031 : 2 PNP outputs & Analog output (4 ~ 20 mA)
- 05 : 2 NPN outputs & Auto-shift input
- 07 : 2 PNP outputs & Auto-shift input

Optional Parts

- BT-8 : Mounting bracket
- BT-9 : Mounting bracket
- PA-C : Panel adapter
- PA-D : Panel adapter + Front protective lid
- CN-0046A : Sensor connector $\varnothing 0.8 \sim \varnothing 1.0$ mm, 26 ~ 24 AWG
- CN-0046B : Sensor connector $\varnothing 1.0 \sim \varnothing 1.2$ mm, 26 ~ 24 AWG
- CN-0046C : Sensor connector $\varnothing 1.2 \sim \varnothing 1.6$ mm, 26 ~ 24 AWG
- KP10 □ -01 : Transducer

Optional Parts

- Mounting Bracket : BT-8 / BT-9



- Sensor Connector CN - 0046 □

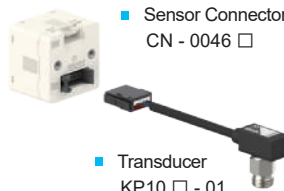

- Transducer KP10 □ - 01

- Panel Adapter : PA-C



- Panel Adapter + Front Protective Lid : PA-D



Dimensions

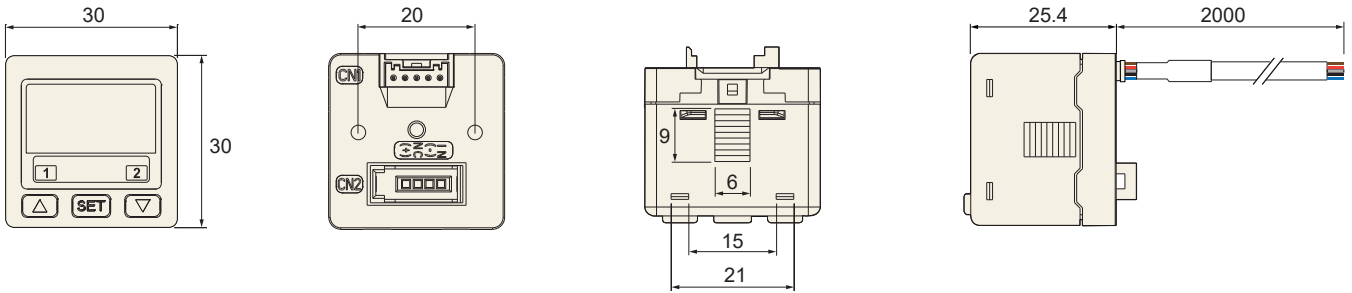

Optional Parts Dimensions

1 Mounting Bracket

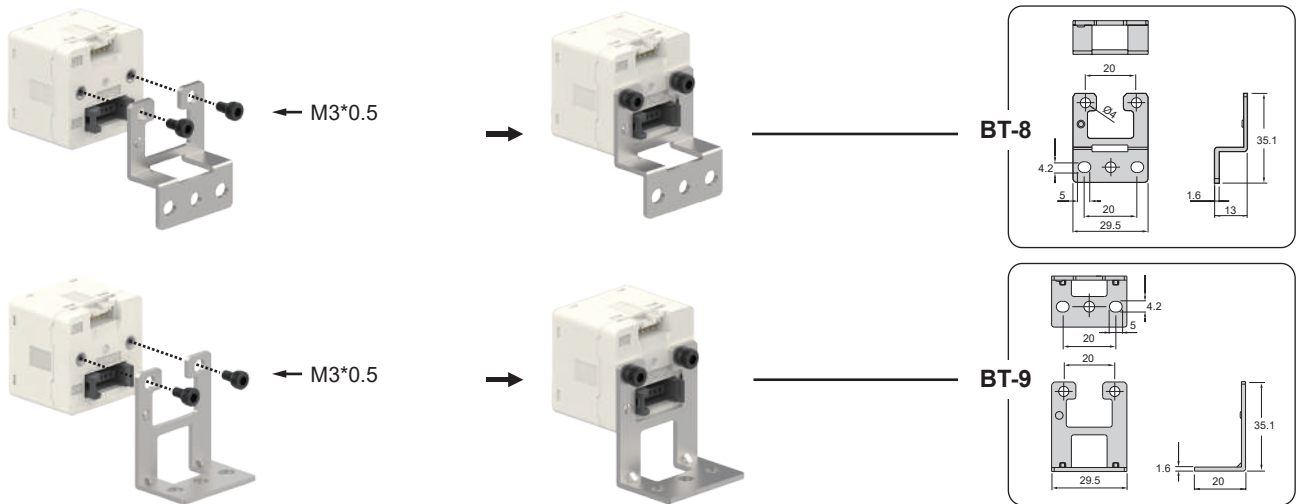

2 Panel Mount Adapter + Front Protective Lid

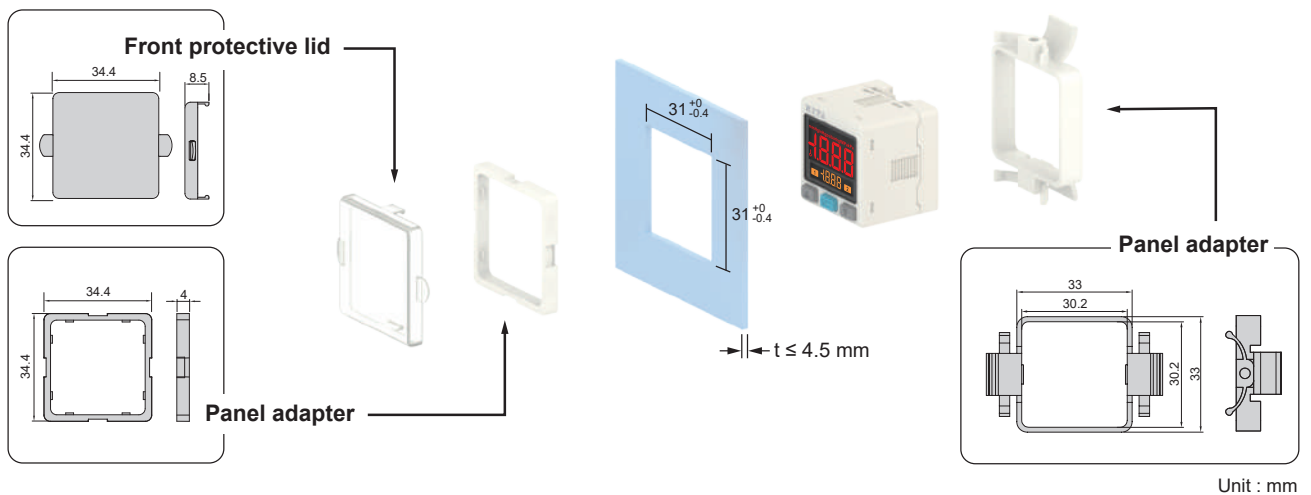

Unit : mm

Features

- Differential pressure sensor
- Analog output : 1 ~ 5 V or 4 ~ 20 mA
- Pressure range : 0 ~ 2 kPa or 0 ~ 5 kPa
- Simple installation, applicable to Ø6 air tubing
- IP40 enclosure



Features Highlight

1 Simple Installation

- Plug-in port for air tube

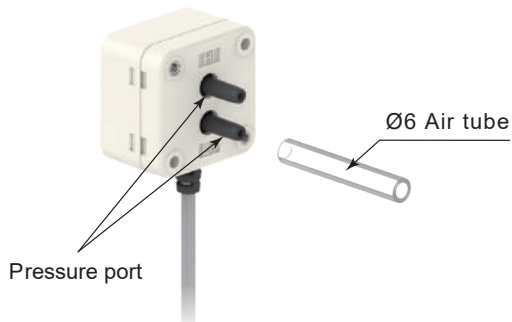

- Plug connect with controller

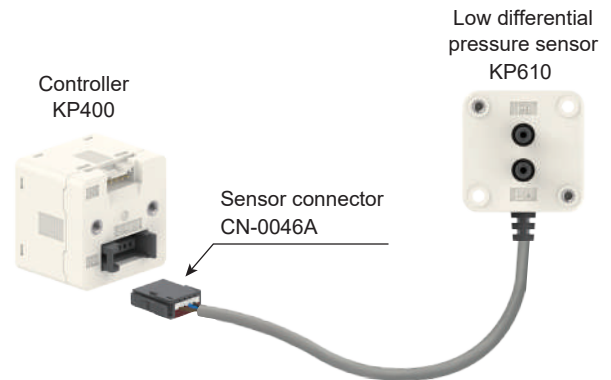

2 Analog Output

- 1 Analog output
Output range 1 to 5 V or 4 to 20 mA, proportional to the pressure range

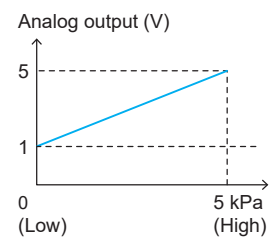
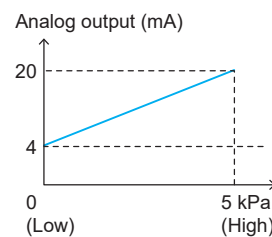
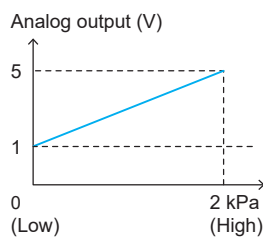
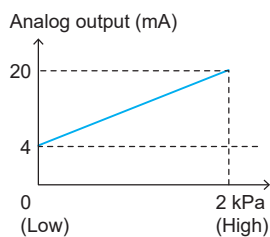

Specifications

MODEL	KP611	KP612
Rated Differential Pressure Range	0 ~ 5 kPa	0 ~ 2 kPa
Operating Pressure Range	-50 ~ 50 kPa ※1	
Withstand Pressure	65 kPa	
Fluid	Filtered air, Non-corrosive / Non-flammable gas	
Power Supply Voltage	12 ~ 24 V DC \pm 10 %, Ripple (P-P) \leq 10 %	
Current Consumption	\leq 15 mA (with no load)	
Analog Output (Voltage Output)	Output Voltage : 1 ~ 5 V \pm 1 % F.S. (within rated pressure range) Linearity : \pm 0.5 % F.S. Output Impedance : about 1 k Ω	
Analog Output (Current Output)	Output Current : 4 ~ 20 mA \pm 1 % F.S. (within rated pressure range) Linearity : \pm 0.5 % F.S. Max. Load Impedance : 250 Ω at power supply of 12 V 600 Ω at power supply of 24 V	
Environment	Enclosure	IP40
	Ambient Temp. Range	Operation : 0 ~ 50 °C, Storage : -20 ~ 70 °C (No condensation or freezing)
	Ambient Humidity Range	Operation / Storage : 35 ~ 85 % RH (No condensation)
	Withstand Voltage	1000 V AC in 1-min (between case and lead wire)
	Insulation Resistance	\geq 50 M Ω (at 500 V DC, between case and lead wire)
	Vibration	Total amplitude 1.5 mm or 10 G, 10 Hz ~ 150 Hz ~ 10 Hz scan for 1 minute, 2 hours each direction of X, Y and Z
	Shock	300 m/s ² (30 G), 3 times each in direction of X, Y and Z
Temperature Characteristic	\pm 3 % F.S. of detected pressure (25 °C) at temp. (Range of 0 ~ 50 °C)	
Port Size	\varnothing 4.8 (\varnothing 4.4 in the end) resin pipe (Applicable to \varnothing 6 air tube)	
Lead Wire	\varnothing 4 Oil-resistance cable (PVC) - 26 AWG (0.15 mm ²) - 3 cores	
Weight (with 2 Meter lead wire)	Approx. 75 g	

NOTE

※1 : To detect differential pressure from 0 ~ 2 kPa or 0 ~ 5 kPa within the range of -50 ~ 50 kPa.

Circuit Wiring Diagrams

KP61 □ - 10 - R6

Analog Output (1 ~ 5 V)

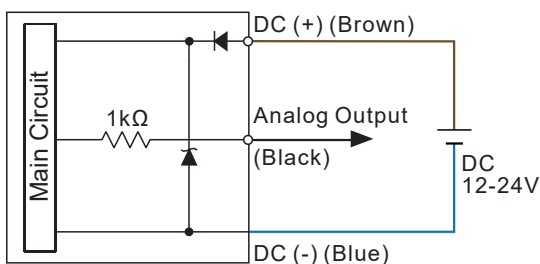

KP61 □ - 11 - R6

Analog Output (4 ~ 20 mA)

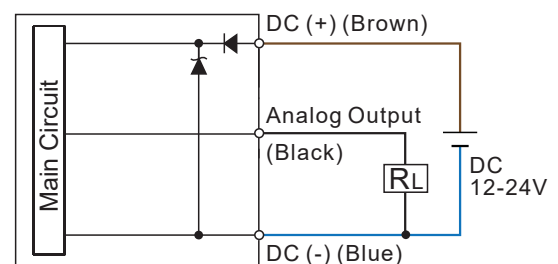

KP610 SERIES

Differential Pressure Sensor

Ordering Information

K P 6 1 1 - 1 0 - R 6

Pressure Range

- 1 : 0 ~ 5 kPa
- 2 : 0 ~ 2 kPa

Output Specifications

- 10 : Analog output (1 ~ 5 V)
- 11 : Analog output (4 ~ 20 mA)

Optional Parts

- BT-16 : Mounting bracket

Dimensions

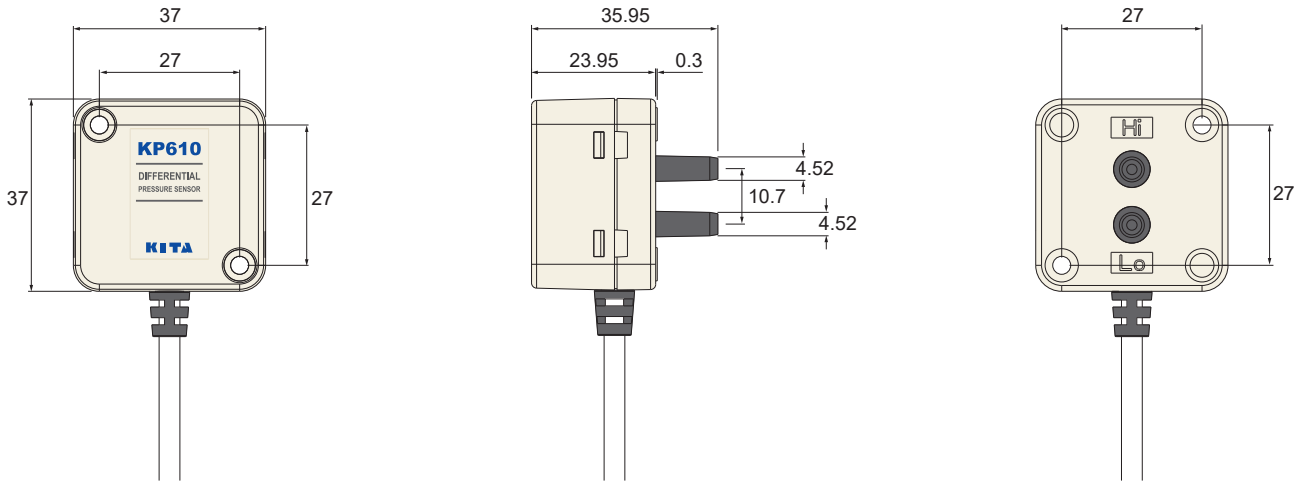

Optional Parts Dimensions

Mounting Bracket

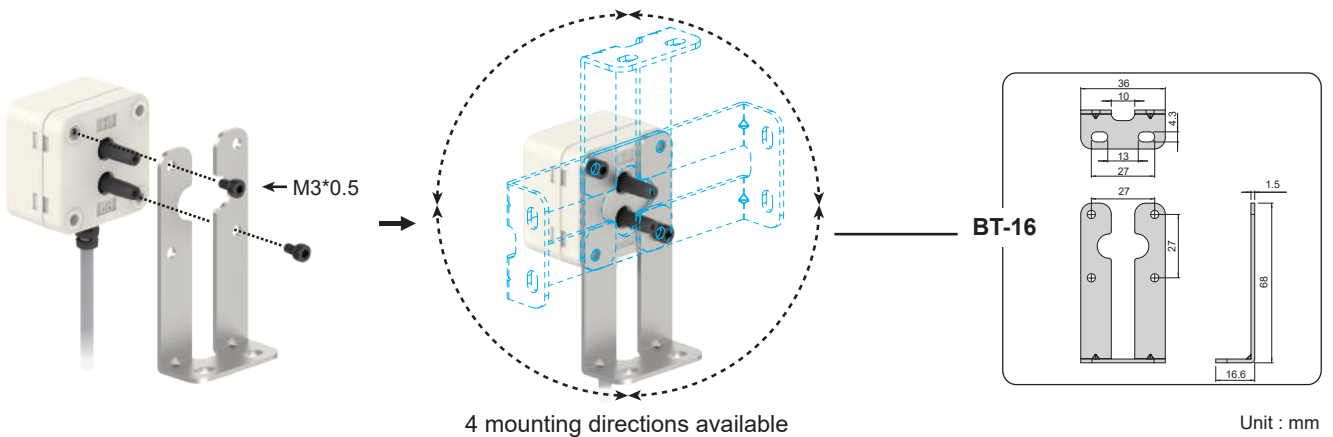

Application

1 Air Flow Detection

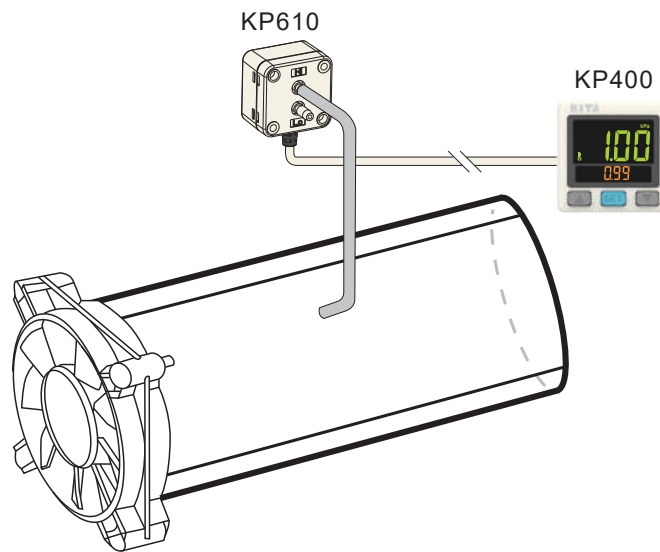

2 Filter Air Monitoring

To monitor the clogging of filter by detecting the differential pressure.

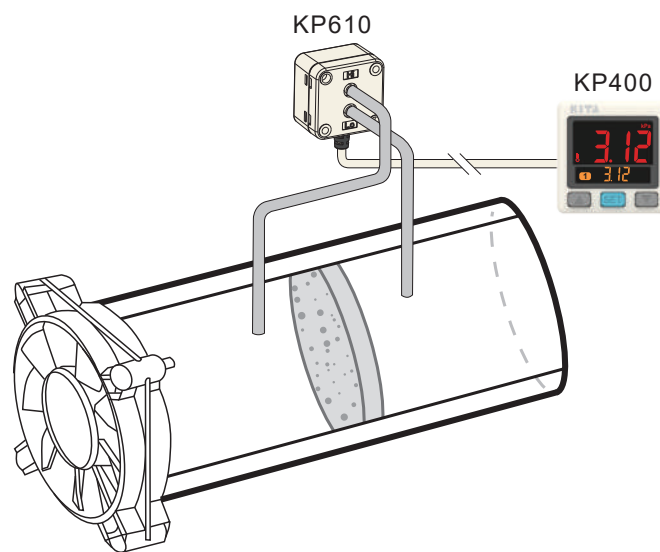

Features

- Digital LCD display, easy readout
- Analog output : 1 ~ 5 V or 4 ~ 20 mA
- IP40 enclosure
- Pressure range :
 0 ~ 1 kPa, 0 ~ 2 kPa, 0 ~ 5 kPa
 -1 ~ 1 kPa, -2 ~ 2 kPa, -5 ~ 5 kPa

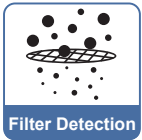

Features Highlight

1 Quick Installation

- Save Installation Time
- Easy Removal

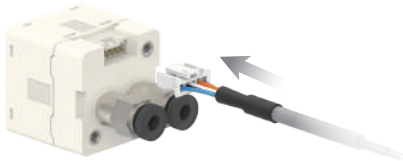

(Removable Data Cable)

2 Key-lock Function

- Key-lock icon is shown on the display when the function is enabled.



3 Save Installation Space

Panel opening for multiple pressure controller

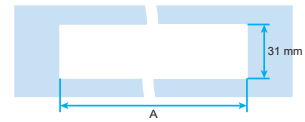

Calculation factor (A) = (34.4 x n) - 3.4
 n = number of controller

Actual dimension after installation



4 Air Flow Detection

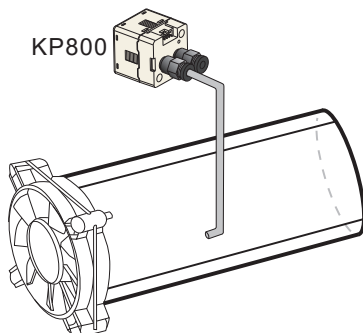

5 Filter Air Monitoring

- To monitor the clogging of filter by detecting the differential pressure.

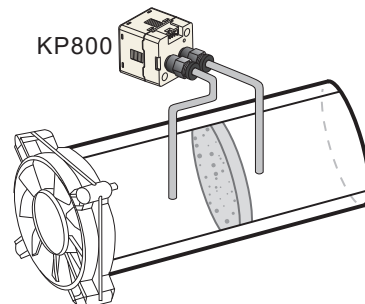

Specifications

MODEL	KP801	KP811	KP802	KP812	KP805	KP815
Rated Pressure Range	0 ~ 1000 Pa	-1000 ~ 1000 Pa	0.00 ~ 2.00 kPa	-2.00 ~ 2.00 kPa	0.0 ~ 5.00 kPa	-5.00 ~ 5.00 kPa
Set Pressure Range	-100 ~ 1000 Pa	-1000 ~ 1000 Pa	-0.20 ~ 2.00 kPa	-2.00 ~ 2.00 kPa	-0.50 ~ 5.00 kPa	-5.00 ~ 5.00 kPa
Withstand Pressure	3 kPa		6 kPa		15 kPa	
Fluid	Filtered air, Non-corrosive / Non-flammable gas					
Set Pressure	Pa	1	-			
Resolution	kPa	-	0.01			
Power Supply Voltage	12 ~ 24 V DC \pm 10 %, Ripple (P-P) \leq 10 %					
Current Consumption	\leq 40 mA (with no load)					
Switch Output	2 NPN : open collector 2 outputs Max. Load Current : 125 mA Max. Supply Voltage : 30 V DC Residual Voltage : \leq 1.5 V			2 PNP : open collector 2 outputs Max. Load Current : 125 mA Max. Supply Voltage : 24 V DC Residual Voltage : \leq 1.5 V		
Repeatability	\pm 0.5 % F.S. \pm 1 digit					
Hysteresis	Hysteresis Mode	Adjustable				
	Window Comparator Mode					
Response Time	\leq 2.0 ms (Chattering-proof function : 32 ms, 128 ms, 1024 ms selectable)					
Output Short Circuit Protection	Yes					
Display	3 ½ digital, 7 segment LCD display (White) (Sampling rate : 5 times / sec.)					
Indicator Accuracy	\pm 2 % F.S. \pm 1 digit (Ambient temperature : 25 \pm 3 °C)					
Switch on Indicator	White Indicator 1 : OUT1 & White Indicator 2 : OUT2					
Analog Output (Voltage Output) ※1	Output Voltage : 1 ~ 5 V \pm 2.5 % F.S. (within rated pressure range) Linearity : \pm 1 % F.S. Output Impedance : about 1 k Ω					
Analog output (Current Output) ※2	Output Current : 4 ~ 20 mA \pm 2.5 % F.S. (within rated pressure range) Linearity : \pm 1 % F.S. Max. Load Impedance : 250 Ω at power supply of 12 V 600 Ω at power supply of 24 V Min. Load Impedance : 50 Ω					
Environment	Enclosure	IP40				
	Ambient Temp. Range	Operation : 0 ~ 50 °C, Storage : -10 ~ 60 °C (No condensation or freezing)				
	Ambient Humidity Range	Operation / Storage : 35 ~ 85 % RH (No condensation)				
	Withstand Voltage	1000 V AC in 1-min (between case and lead wire)				
	Insulation Resistance	\geq 50 M Ω (at 500 V DC, between case and lead wire)				
	Vibration	Total amplitude 1.5 mm or 10 G, 10 Hz ~ 150 Hz ~ 10 Hz scan for 1 minute, 2 hours each direction of X, Y and Z				
	Shock	100 m/s ² (10 G), 3 times each in direction of X, Y and Z				
Temperature Characteristic	\pm 3 % F.S. of detected pressure (25 °C) at temp. (Range of 0 ~ 50 °C)					
Port Size	M5 : M5 female thread					
Lead Wire	\varnothing 4 Oil-resistance cable (PVC) - 26 AWG (0.15 mm ²) - 5 cores					
Weight (with 2 meter lead wire)	Approx. 75 g					

NOTE

※1 : If analog voltage output is selected, the analog current output cannot be selected at the same time.

※2 : If analog current output is selected, the analog voltage output cannot be selected at the same time.

KP800 SERIES

Differential Pressure Sensor

Panel Description

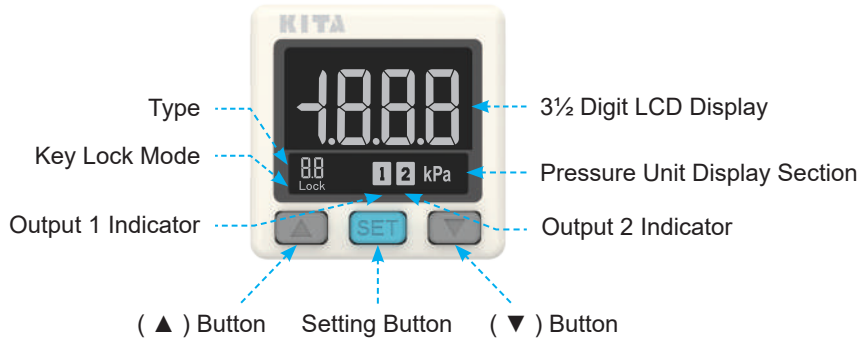

Installation Precautions

- Do not use the wrench on the plastic body while connecting the sensor connector or pressure port.
- Over tightening may cause damage to the port thread, mounting bracket and pressure sensor. Under tightening may result loosen or leakage.
- Apply air pressure and power after installation, make necessary adjustments and inspect any possible signs of leakage to ensure proper installation.
- Do not insert metal or sharp objects into the pressure port.

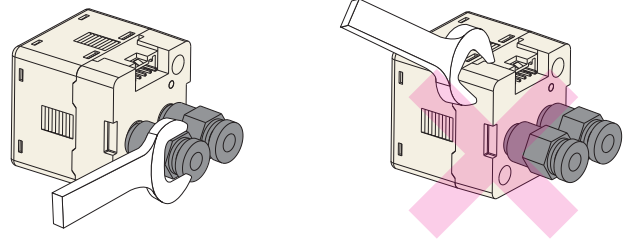

Output Circuit Wiring Diagrams

KP8□ - 010 - M5

2 NPN + Analog Output (1 ~ 5 V)

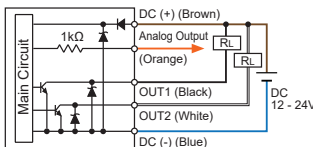

KP8□ - 011 - M5

2 NPN + Analog Output (4 ~ 20 mA)

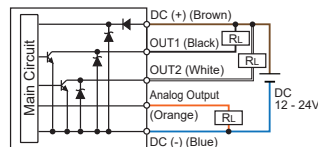

KP8□ - 030 - M5

2 PNP + Analog Output (1 ~ 5 V)

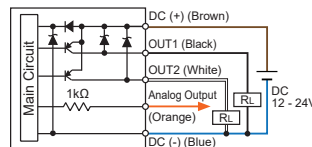

KP8□ - 031 - M5

2 PNP + Analog Output (4 ~ 20 mA)

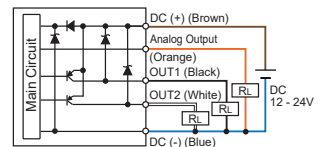

Ordering Information

K P 8 0 1 - 0 1 0 - M 5

Pressure Range

- 01 : (-100 ~ 1000 Pa)
- 02 : (-0.20 ~ 2.00 kPa)
- 05 : (-0.50 ~ 5.00 kPa)
- 11 : (-1000 ~ 1000 Pa)
- 12 : (-2.00 ~ 2.00 kPa)
- 15 : (-5.00 ~ 5.00 kPa)

Output Specifications

- 010 : 2 NPN output + Analog output (1 ~ 5 V)
- 011 : 2 NPN output + Analog output (4 ~ 20 mA)
- 030 : 2 PNP output + Analog output (1 ~ 5 V)
- 031 : 2 PNP output + Analog output (4 ~ 20 mA)

Optional Parts

- BT-20 : Mounting bracket
- BT-21 : Mounting bracket
- PA-C : Panel adapter
- PA-D : Panel adapter + Front protective lid

Optional Parts

- Mounting Bracket : BT-20 / BT-21



- Panel Adapter : PA-C



- Panel Adapter + Front Protective Lid : PA-D



Dimensions

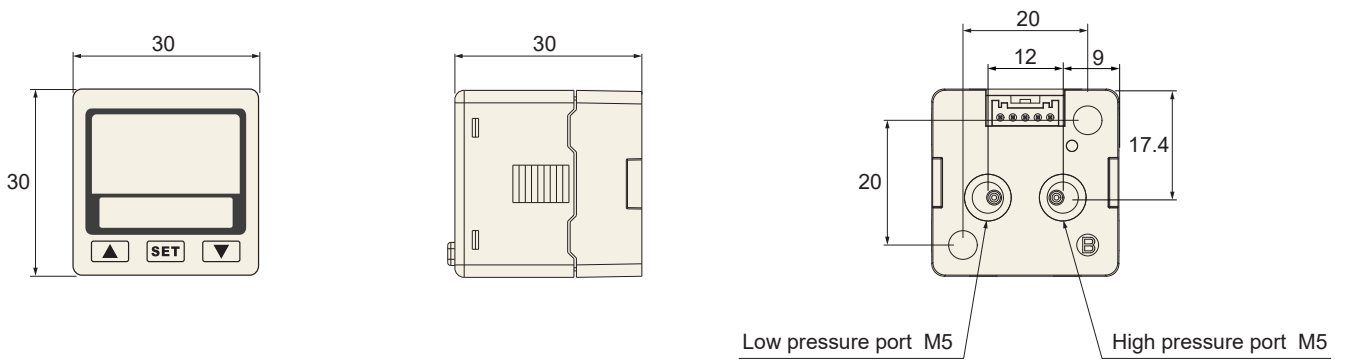

Optional Parts Dimensions

1 Mounting Bracket

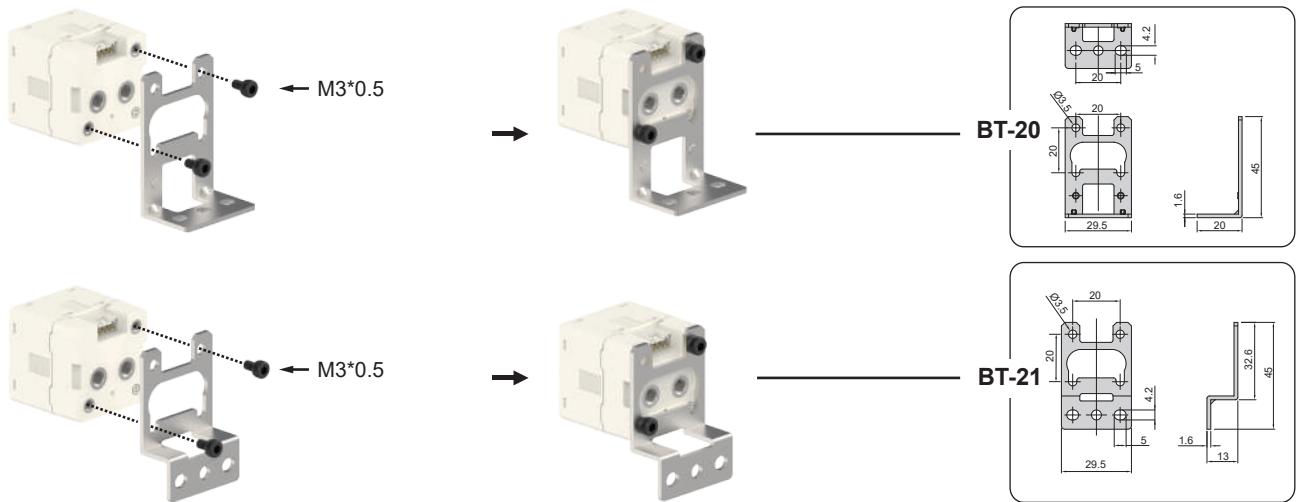

2 Panel Mount Adapter + Front Protective Lid

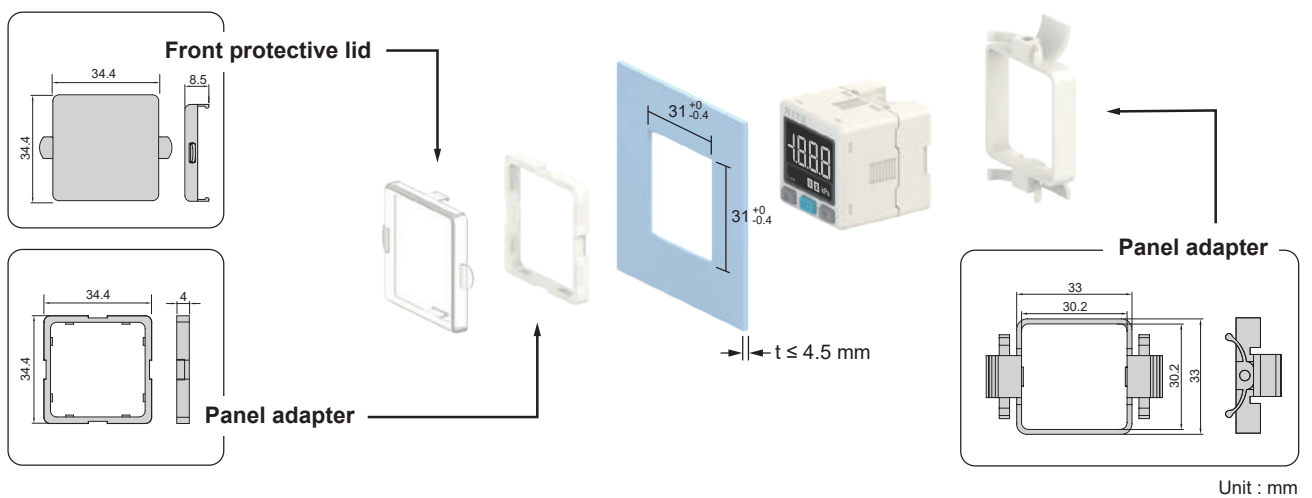

Features

- Digital LCD display, easy readout
- Pressure range :
-10 ~ 10 kPa, -1 ~ 1 kPa,
-2 ~ 2 kPa, -5 ~ 5 kPa
- RS485 Modbus RTU
- Remote control /
Real-time monitoring

RS485 MODBUS CONTROL

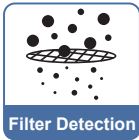
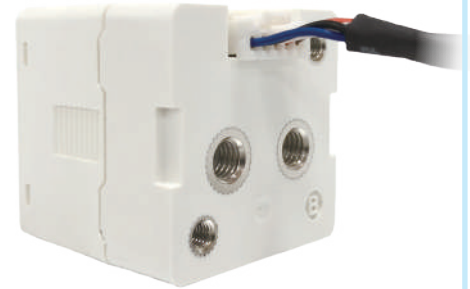

Features Highlight

1 Quick Installation

- Save Installation Time
- Easy Removal

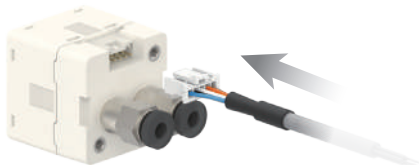

(Removable Data Cable)

2 Key-lock Function

- Key-lock icon is shown on the display when the function is enabled.



3 Save Installation Space

Panel opening for multiple pressure controller



Calculation factor (A) = (34.4 x n) - 3.4
n = number of controller

Actual dimension after installation



4 Air Flow Detection

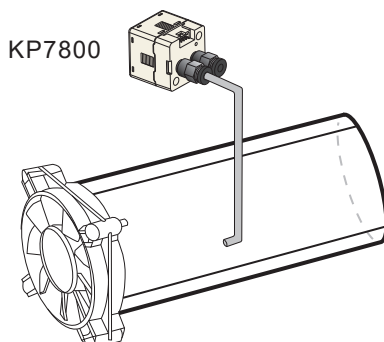

5 Filter Air Monitoring

- To monitor the clogging of filter by detecting the differential pressure.

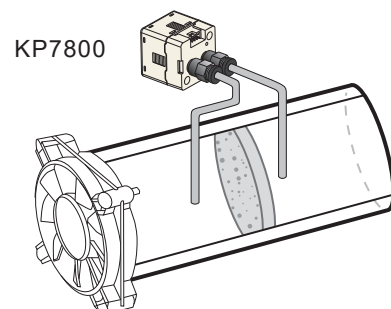



Specifications

MODEL	KP7810	KP7811	KP7812	KP7815
Rated Pressure Range	-10.00 ~ 10.00 kPa	-1.000 ~ 1.000 kPa	-2.00 ~ 2.00 kPa	-5.00 ~ 5.00 kPa
Set Pressure Range	-10.00 ~ 10.00 kPa	-1.000 ~ 1.000 kPa	-2.00 ~ 2.00 kPa	-5.00 ~ 5.00 kPa
Withstand Pressure	30 kPa	3 kPa	6 kPa	15 kPa
Fluid	Filtered air, Non-corrosive / Non-flammable gas			
Set Pressure Resolution	kPa	0.01	0.001	0.01
	mmAq ※1	1	0.1	1
Power Supply Voltage	12 ~ 24 V DC ± 10 %, Ripple (P-P) ≤ 10 %			
Current Consumption	≤ 40 mA (with no load)			
Switch Output	1 NPN : open collector 1 output Max. load current : 125 mA Max. supply voltage : 30 V DC Residual voltage : ≤ 1.5 V		1 PNP : open collector 1 output Max. load current : 125 mA Max. supply voltage : 24 V DC Residual voltage : ≤ 1.5 V	
Repeatability	± 0.5 % F.S. ± 1 digit			
Hysteresis	Hysteresis Mode	Adjustable		
	Window Comparator Mode			
Response Time	≤ 2.0 ms (Chattering-proof function : 32 ms, 128 ms, 1024 ms selectable)			
Output Short Circuit Protection	Yes			
Display	4 digital, 7 segment LCD display (White) (Sampling rate : 0.1 ~ 3 sec select)			
Indicator Accuracy	± 2 % F.S. ± 1 digit (Ambient temperature : 25 ± 3 °C)			
Switch on Indicator	White Indicator 1 : OUT1			
Environment	Enclosure	IP40		
	Ambient Temp. Range	Operation : 0 ~ 50 °C, Storage : -10 ~ 60 °C (No condensation or freezing)		
	Ambient Humidity Range	Operation / Storage : 35 ~ 85 % RH (No condensation)		
	Withstand Voltage	1000 V AC in 1-min (between case and lead wire)		
	Insulation Resistance	≥ 50 MΩ (at 500 V DC, between case and lead wire)		
	Vibration	Total amplitude 1.5 mm or 10 G, 10 Hz ~ 150 Hz ~ 10 Hz scan for 1 minute, 2 hours each direction of X, Y and Z		
	Shock	100 m/s ² (10 G), 3 times each in direction of X, Y and Z		
Temperature Characteristic	± 3 % F.S. of detected pressure (25 °C) at temp. (Range of 0 ~ 50 °C)			
Communication Interface	RS485			
Port Size	M5 : M5 female thread			
Lead Wire	Ø4 Oil-resistance cable (PVC) - 26 AWG (0.15 mm ²) - 5 cores			
Weight (with 2 Meter Lead Wire)	Approx. 75 g			

NOTE

※1 : When the unit is mmAq, the pressure unit is not displayed.

KP7800 SERIES

Differential Pressure Sensor

Panel Description

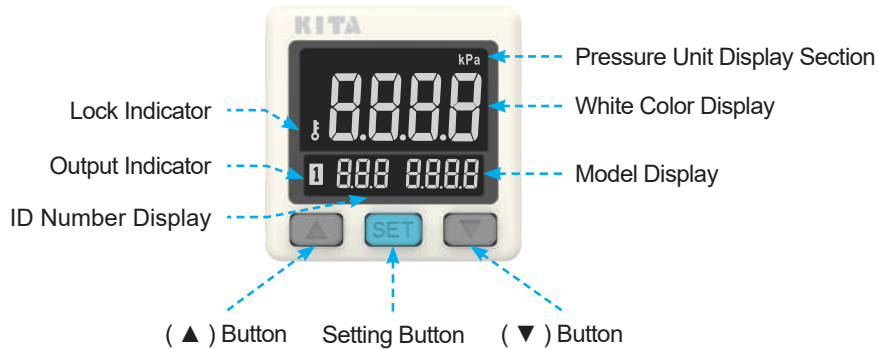

Installation Precautions

- Do not use the wrench on the plastic body while connecting the sensor connector or pressure port.
- Over tightening may cause damage to the port thread, mounting bracket and pressure sensor. Under tightening may result loosen or leakage.
- Apply air pressure and power after installation, make necessary adjustments and inspect any possible signs of leakage to ensure proper installation.
- Do not insert metal or sharp objects into the pressure port.

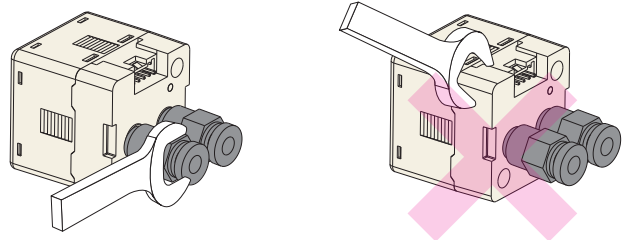

Output Circuit Wiring Diagrams

KP78□ - 02 - M5
1 NPN + RS485

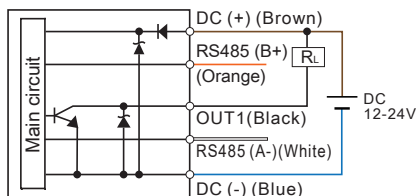

KP78□ - 04 - M5
1 PNP + RS485

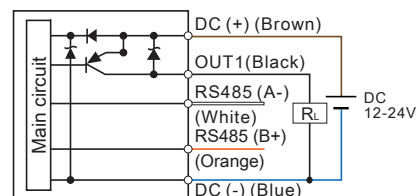

* Procedure to wiring RS485 products : To prevent product damage due to short circuit , MUST do RS485 line connection BEFORE power line connection.

Ordering Information

K P 7 8 0 1 - 0 2 - M 5

Pressure Range

10 : -10.00 ~ 10.00 kPa 12 : -2.000 ~ 2.000 kPa
11 : -1.000 ~ 1.000 kPa 15 : -5.000 ~ 5.000 kPa

Output Specifications

02 : 1 NPN output + RS485
04 : 1 PNP output + RS485

Optional Parts

BT-20 : Mounting bracket
BT-21 : Mounting bracket
PA-C : Panel adapter
PA-D : Panel adapter + Front protective lid

Optional Parts

- Mounting Bracket : BT-20 / BT-21



- Panel Adapter : PA-C



- Panel Adapter + Front Protective Lid : PA-D



Dimensions

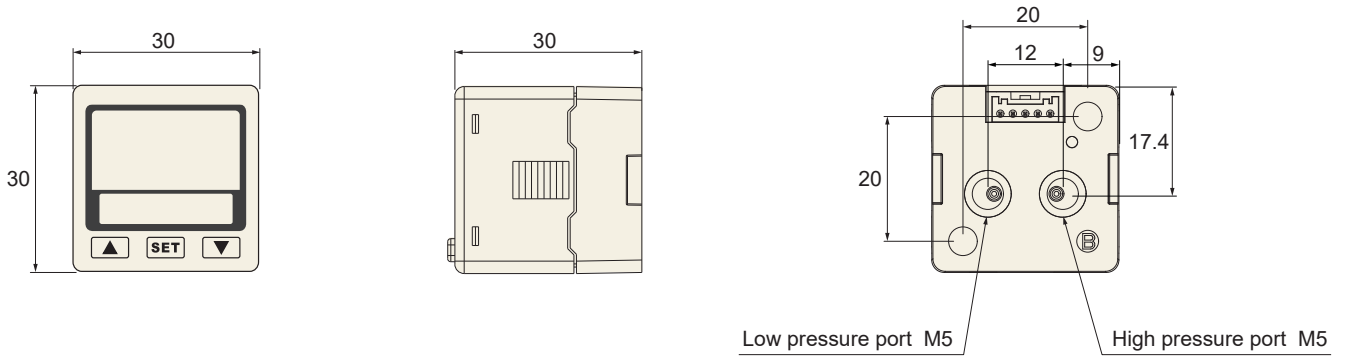

Optional Parts Dimensions

1 Mounting Bracket

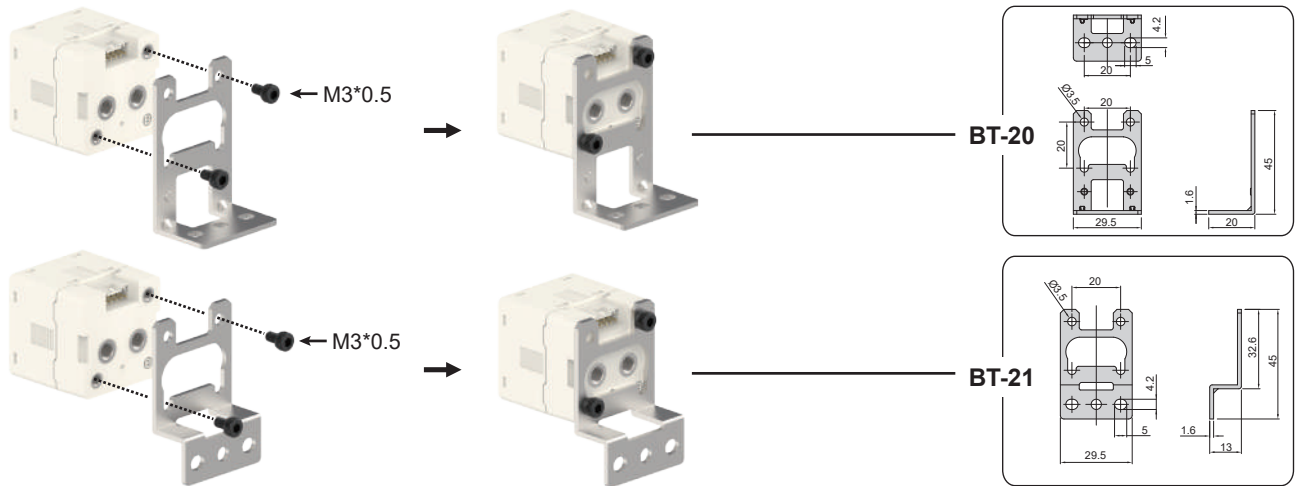

2 Panel Mount Adapter + Front Protective Lid

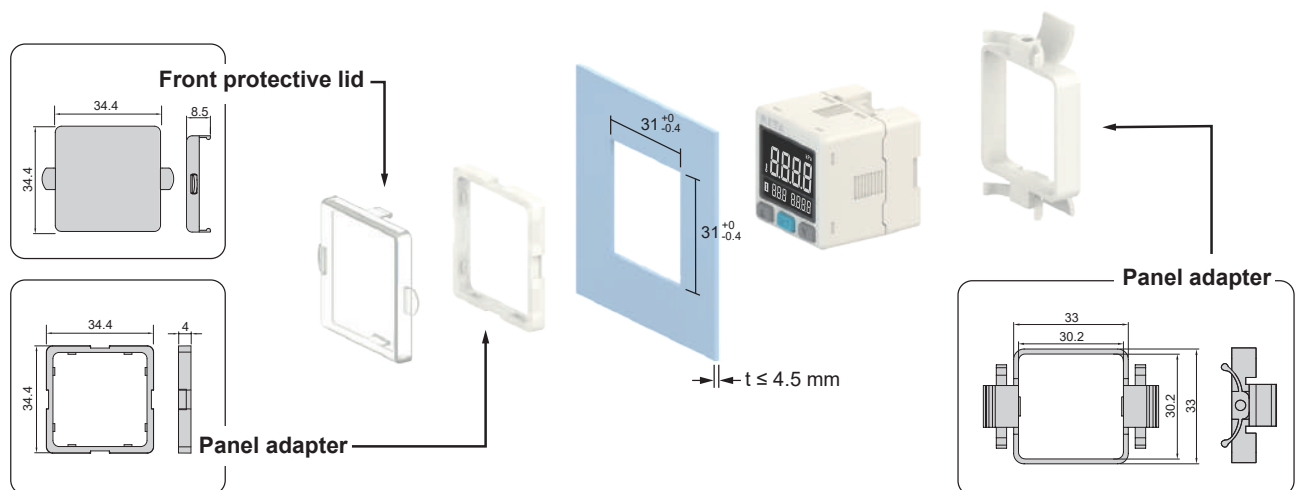

Unit : mm

Features

- Digital LCD display
- IP65 enclosure
- Pressure range : 0 ~ 1000 kPa
- RS485 Modbus RTU
- High-resolution (10x)
- Selectable NPN or PNP open collector

RS485 MODBUS CONTROL

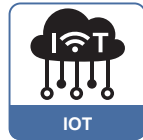
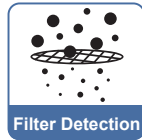

Features Highlight

1 Quick Installation

- Save Installation Time
- Easy Removal

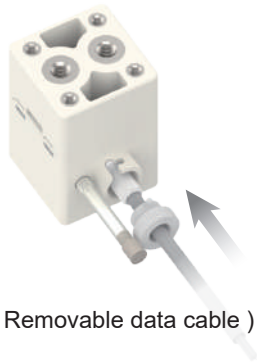

2 High Resolution Mode

- High resolution mode is settable in differential pressure range : -199.9 kPa ~ 199.9 kPa.
Under high resolution mode, the detection are 10 times accuracy that able to measure differential pressure.

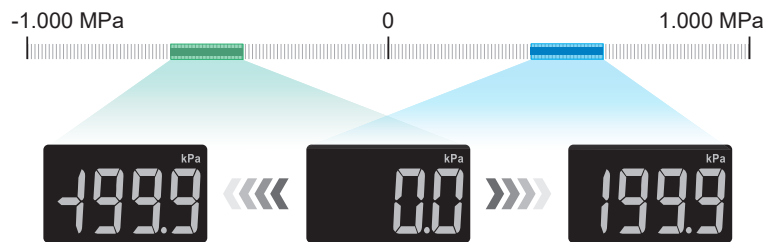

3 Filter Air Monitoring

- To monitor the clogging of filter by detecting the differential pressure.

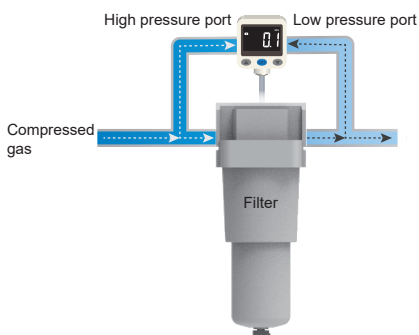

4 Leakage Test

- To detect the differential pressure decay by sensing the change of line pressure.

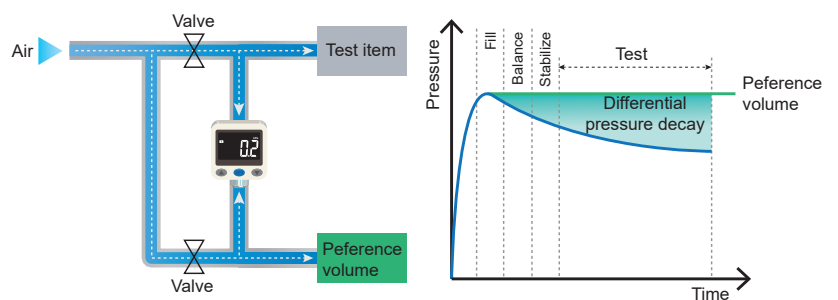

Specifications

Model		KDS-P-02	KDS-P-04
Rated Pressure Range		-1000 ~ 1000 kPa	
Setting Pressure Range		0 ~ 1000 kPa	
Withstand Pressure		1200 kPa	
Fluid		Filtered air, Non-corrosive / Non-flammable gas	
Set Pressure Resolution	Standard Mode	1 kPa	
	High Resolution Mode ※1	0.1 kPa	
Power Supply Voltage		12 to 24 V DC ± 10 %, Ripple (P-P) ≤ 10 %	
Current Consumption		≤ 20 mA	
Switch Output		1 NPN open collector ※2 Max. Load Current : 200 mA Max. Supply Voltage : 30 V DC Residual Voltage : ≤ 1.5 V	1 PNP open collector ※2 Max. Load Current : 200 mA Max. Supply Voltage : 24 V DC Residual Voltage : ≤ 1.5 V
Repeatability (Switch Output)		± 0.2 % F.S. ± 1 digit	
Hysteresis	Hysteresis Mode	1 ~ 15 digits	
	Window Comparator Mode		
Output Short Circuit Protection		Yes	
7 Segment LCD Display		3 ½ digital, 7 segment LCD display (White) (Sampling rate : 5 times / sec.)	
Indicator Accuracy	Standard Mode	± 0.3 % F.S. ± 1 digit (Ambient temperature : 25 ± 3 °C)	
	High Resolution Mode	± 0.1 % F.S. ± 1 digit (Ambient temperature : 25 ± 3 °C)	
Switch on Indicator		White indicator 1 : OUT	
Environment	Enclosure	IP65 ※3	
	Ambient Temp. Range	Operation : 0 ~ 50 °C, Storage : -10 ~ 60 °C (No condensation or freezing)	
	Ambient Humidity Range	35 ~ 85 % RH (No condensation)	
	Withstand Voltage	1000 V AC in 1-min (between case and lead wire)	
	Insulation Resistance	≥ 50 MΩ (at 500 V DC, between case and lead wire)	
	Vibration	Total amplitude 1.5 mm , 10 Hz ~ 55 Hz ~ 10 Hz scan for 1 minute, 2 hours each direction of X, Y and Z	
	Shock	100 m/s ² (10 G), 3 times each in direction of X, Y and Z	
Temperature Characteristic	Standard Mode	± 0.5 % F.S. of detected pressure (25 °C) at temp. Range of 0 ~ 50 °C	
	High Resolution Mode	± 5 % F.S. of detected pressure (25 °C) at temp. Range of 0 ~ 50 °C	
Communication Interface		RS485 RTU	
Port Size		M5 : M5 female thread	
Lead Wire		Ø4 Oil-resistance cable (PVC) - 26 AWG (0.15 mm ²) - 5 cores	
Weight (With 2 Meter Lead Wire)		Approx. 104 g	

NOTE

※1 : High resolution mode is settable in differential pressure range : -199.9 kPa ~ 199.9 kPa

※2 : Selectable NPN or PNP open collector circuits in setting.

※3 : Dustproof protector must be installed to maintain IP65.

Panel Description



Installation Precautions

- While connecting a joint to the pressure port, be sure that tightening torque must NOT exceed 1.0 N·m.

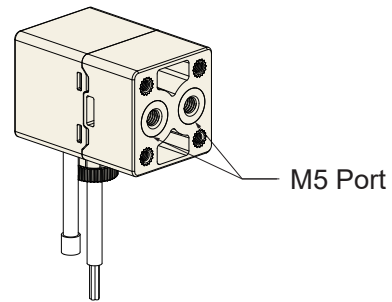

Output Circuit Wiring Diagrams

KDS - P - 02
NPN + RS485

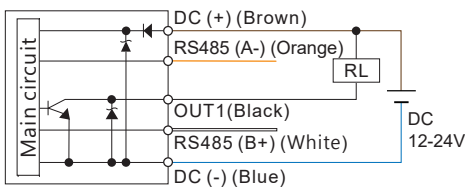

KDS - P - 04
PNP + RS485

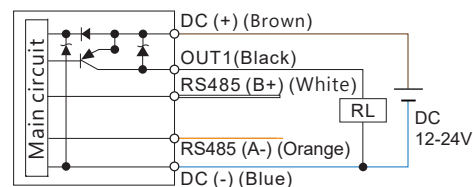

* Procedure to wiring RS485 products : To prevent product damage due to short circuit , MUST do RS485 line connection BEFORE power line connection.

Ordering Information

K D S - P - 0 2 - M 5

Pressure Range

P : Positive (0 ~ 1000 kPa)

Output Specifications

02 : 1 NPN Output + RS485
04 : 1 PNP Output + RS485

Optional Parts

BT-18 : Mounting bracket
BT-19 : Mounting bracket
PA-E : Panel adapter
PA-F : Panel adapter + Front protective lid

Optional Parts

- Mounting bracket : BT-18 / BT-19

- Panel adapter : PA-E

- Panel adapter + Front protective lid : PA-F



Dimensions

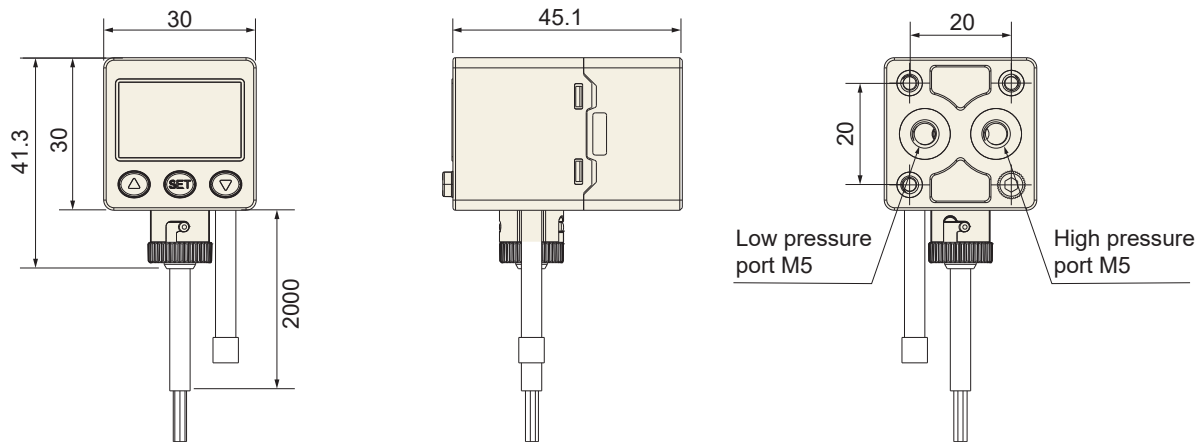

Optional Parts Dimensions

1 Mounting Bracket

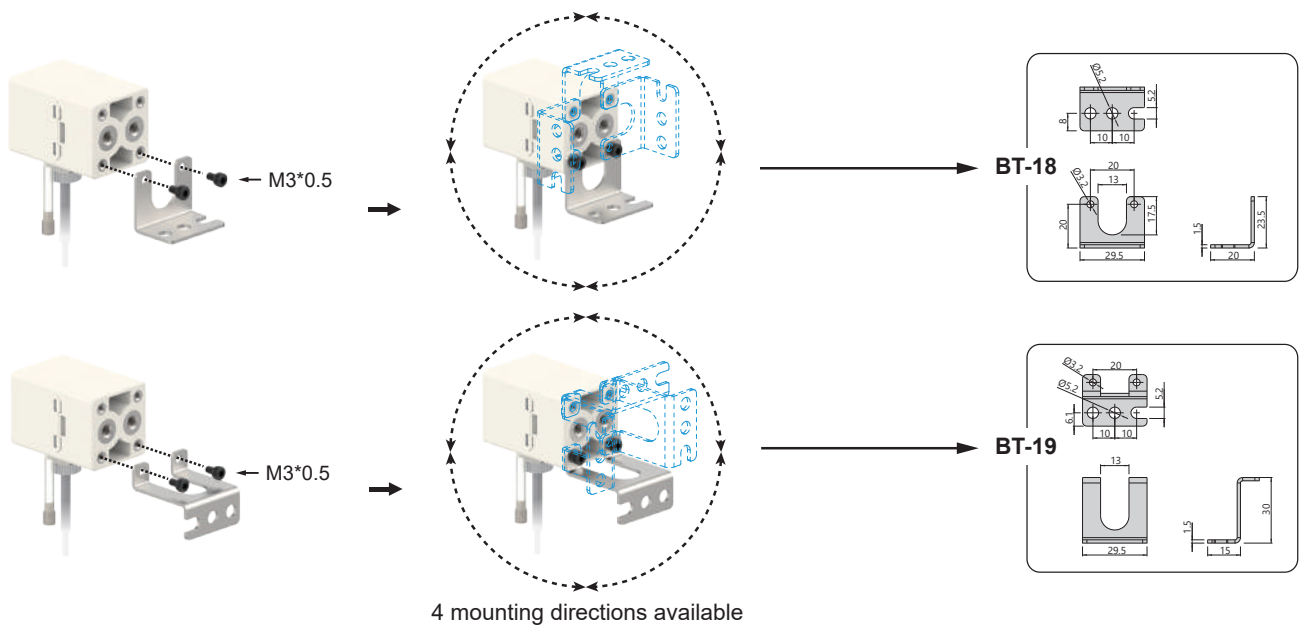

2 Panel Mount Adapter + Front Protective Lid

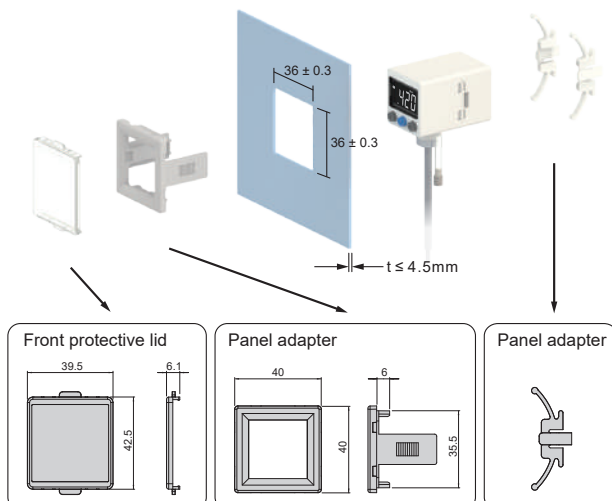

3 IP65 Protector

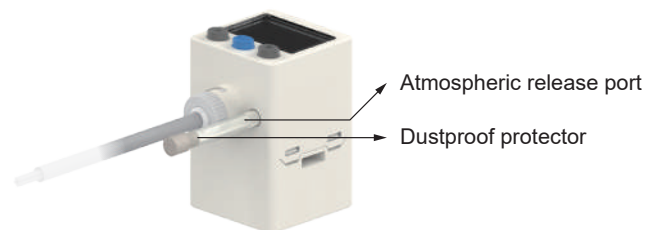

Caution :

This device must be installed to maintain IP65 (Dust and splash proof) enclosure rating.

Unit : mm

Features

- Digital LCD display, easy readout
- IP65 enclosure
- Detection distance : 0.01 ~ 0.10 mm
- Repeatability : $\pm 5 \mu\text{m}$

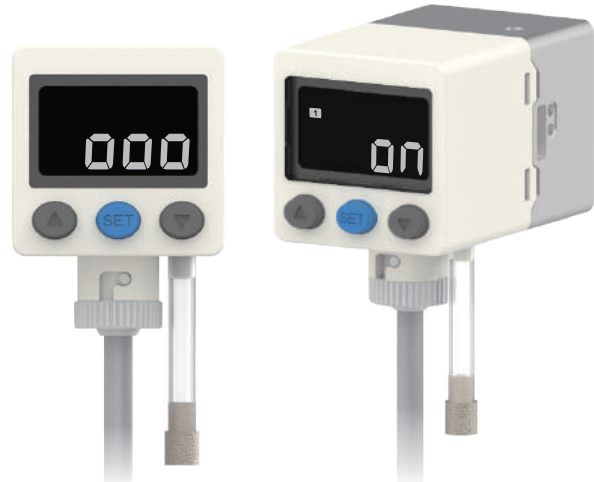

Features Highlight

1 Easy to Check Workpiece Located on the Right Place

- Intuitive recognize in graphic interface, easy to check the gap between workpiece and platform.

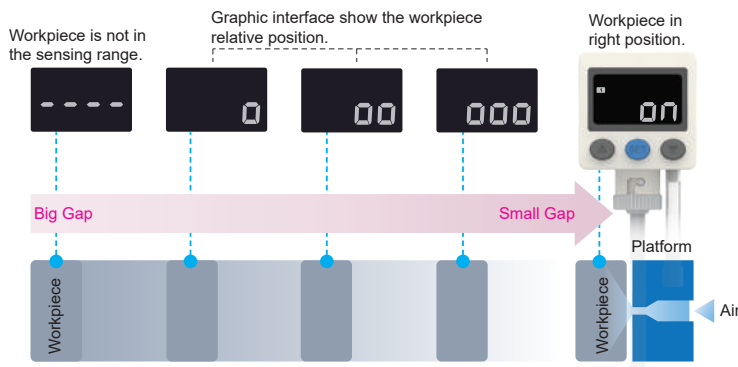

2 IP65 Compliance



3 Reference Gap Easy Setting

- To set the reference gap by press up Δ + down ∇ at the same time.

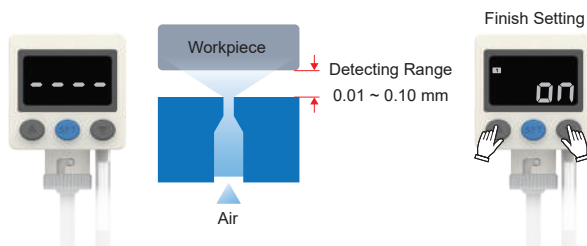

4 Repeatability : $\pm 5 \mu\text{m}$

- The higher repeatability is, the more guarantee is.

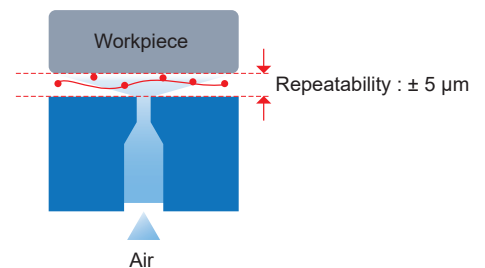

5 The Gap Cause by Shavings Can Be Detectable

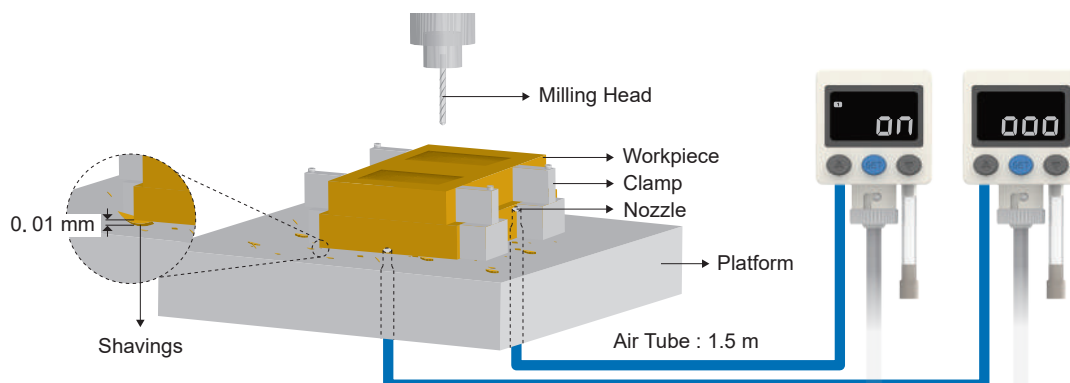

Specifications

MODEL	KGS01-G-02	KGS01-G-04
Detection Distance	0.01 ~ 0.10 mm	
Operating Pressure Range	250 ~ 350 kPa	
Withstand Pressure	600 kPa	
Fluid	Clean air, Non-corrosive / Non-flammable gas ※1	
Power Supply Voltage	12 ~ 24 V DC ± 10 %, Ripple (P-P) ≤ 10 %	
Current Consumption	≤ 20 mA	
Switch Output	1 NPN : open collector 1 output Max. Load Current : 125 mA Max. Supply Voltage : 30 V DC Residual Voltage : ≤ 1.5 V	1 PNP : open collector 1 output Max. Load Current : 125 mA Max. Supply Voltage : 24 V DC Residual Voltage : ≤ 1.5 V
Consumption Flow Rate	≤ 8 L / min @ 300 kPa	
Repeatability	± 5 μm	
Hysteresis	Adjustable 1 ~ 30 digits	
Output Short Circuit Protection	Yes	
Display	3 ½ digital, 7 segment LCD display (White) (Sampling rate : 5 times / sec.)	
Switch on Indicator	White Indicator 1 : OUT	
Detection Nozzle	Ø1.5 mm ※2	
Environment	Enclosure	IP65 ※3
	Ambient Temp. Range	Operation : 0 ~ 50 °C, Storage : -10 ~ 60 °C (No condensation or freezing)
	Ambient Humidity Range	Operation / Storage : 35 ~ 85 % RH (No condensation)
	Withstand Voltage	1000 V AC in 1-min (between case and lead wire)
	Insulation Resistance	≥ 50 MΩ (at 500 V DC, between case and lead wire)
	Vibration	Total amplitude 1.5 mm or 10 G, 10 Hz ~ 55 Hz ~ 10 Hz scan for 1 minute, 2 hours each direction of X, Y and Z
Piping Specifications	Shock	100 m/s ² (10 G), 3 times each in direction of X, Y and Z
	Supply Port	Rc1/8" ※4
Detection Port		
Lead wire	Ø4 Oil-resistance cable (PVC) - 26 AWG (0.15 mm ²) - 3 cores	
Weight (with 2 meter lead wire)	Approx. 115 g	

NOTE

※1 : Please use air filter to clean air (5 μm or less) and install precision regulator.

※2 : Detection nozzle

* No chamfering on nozzle tip

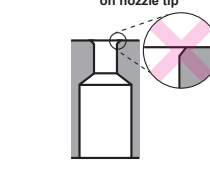
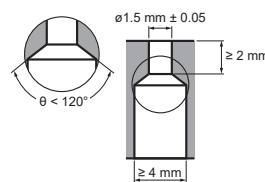
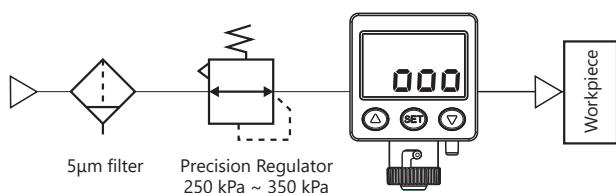

Correct Nozzle Shape

Incorrect Nozzle Shape

※3 : Dustproof protector must be installed to maintain IP65.

※4 : Back side of product, please refer to product dimension.

Detection Circuit

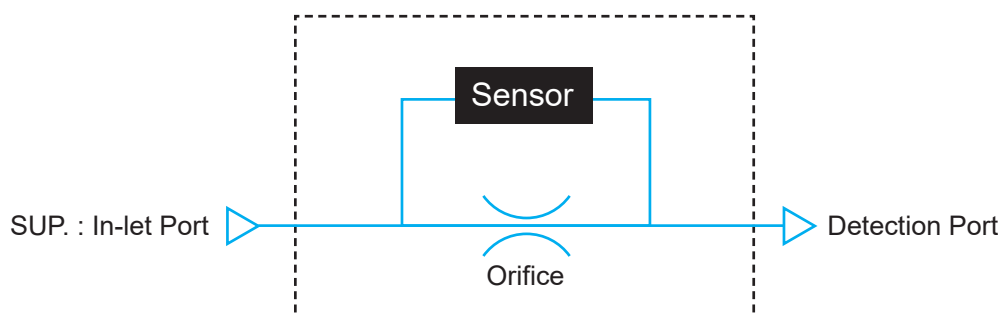

Panel Description

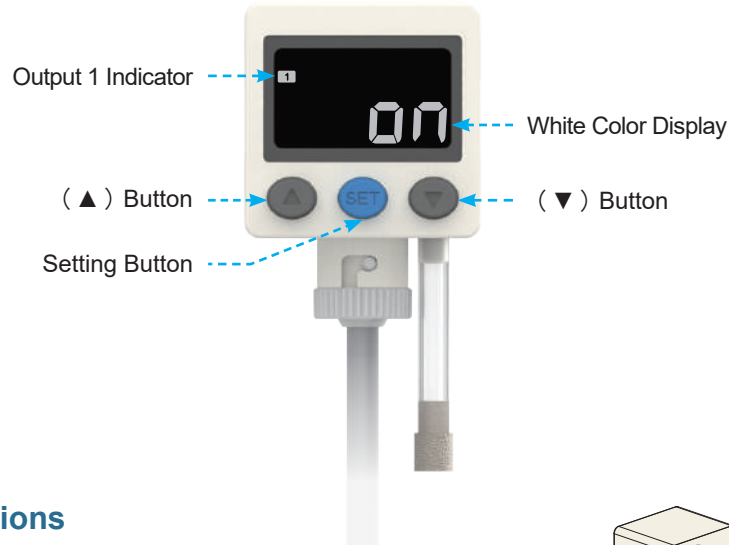

Installation Precautions

- When mounting, always use the wrench on the metallic area near the pressure port. Never apply a wrench to the plastic body, it will damage the sensor.
- Over tightening may cause damages to the port thread, mounting bracket and pressure sensor. Under tightening may result loosen or leakage.

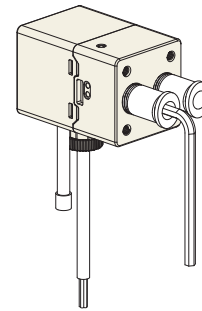

* Internal Hex Straight Tube-to-Tube Adaptors are recommended.

Circuit Wiring Diagrams

KGS01- G - 02

1 NPN Output

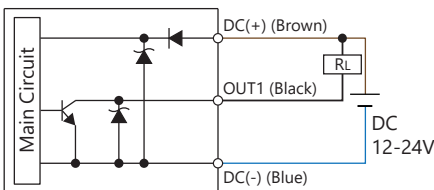

KGS01- G - 04

1 PNP Output

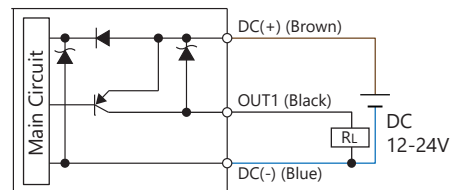

Ordering Information

K G S 0 1 - G - 0 2 - F 1 C

Rated Distance Range

G : 0.01 ~ 0.10 mm

Output Specifications

02 : 1 NPN Output
04 : 1 PNP Output

Pressure Port

F1C : Rc1/8"

Optional Parts

BT-18 : Mounting bracket
BT-19 : Mounting bracket
PA-E : Panel adapter
PA-F : Panel adapter + Front protective lid

Optional Parts

- Mounting bracket : BT-18 / BT-19

- Panel adapter : PA-E

- Panel adapter + Front protective lid : PA-F



Dimensions

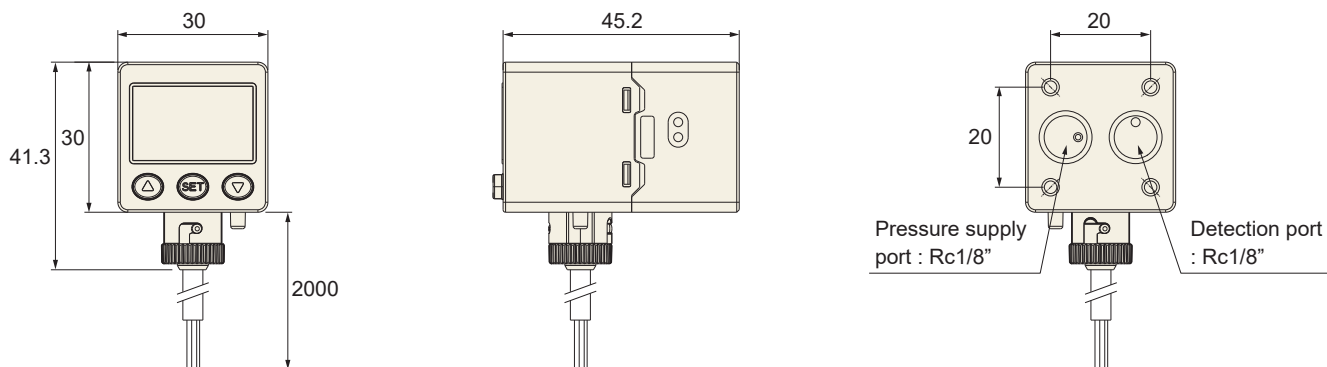

Optional Parts Dimensions

1 Mounting Bracket

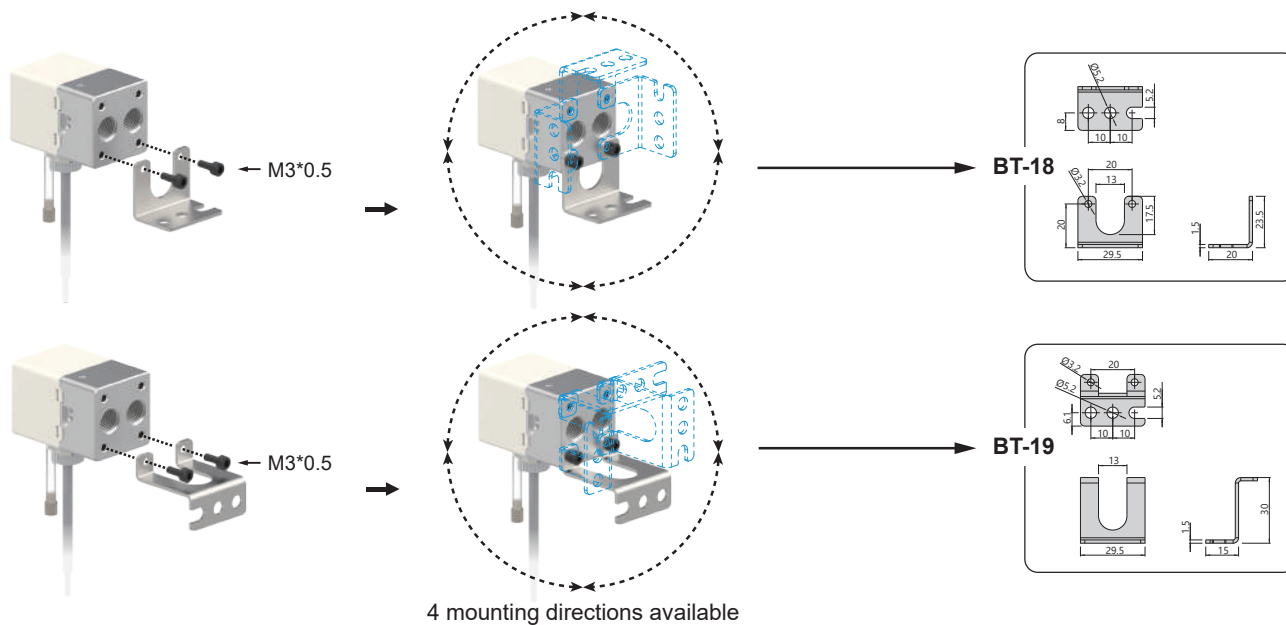

2 Panel Mount Adapter + Front Protective Lid

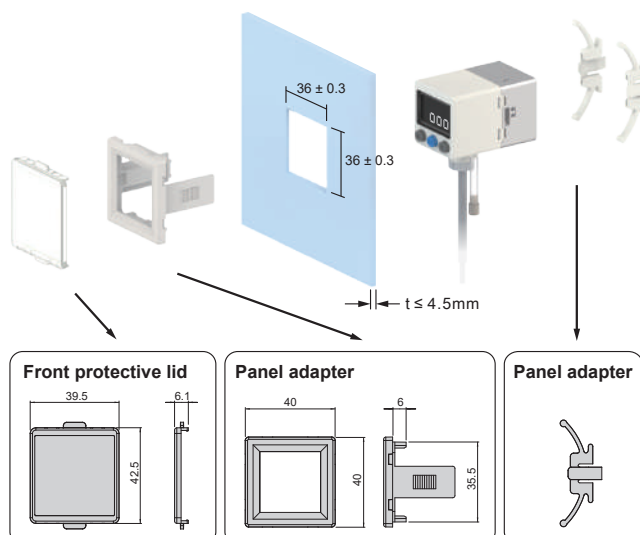

3 IP65 Protector

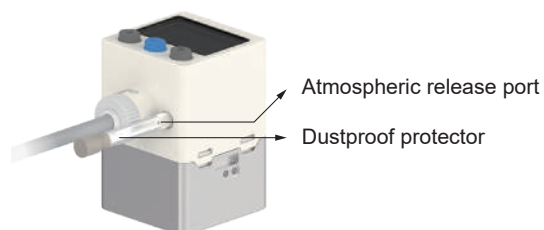

Caution :

This device must be installed to maintain IP65 (Dust and splash proof) enclosure rating.

Unit : mm

Features

- Flow and pressure dual sensor
- Flow and pressure 4 digit, 7 segment dual LCD display
- 7 segment 8 digit LCD display. Accumulated flow rate display at a glance.

RS485 MODBUS CONTROL

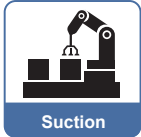

Features Highlight

1 2-in-1 Design

- Pressure and flow rate simultaneous monitoring

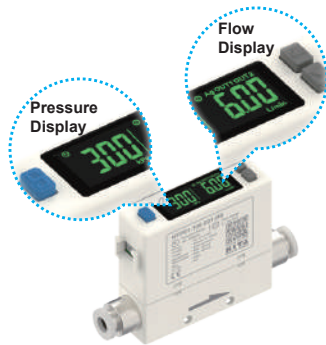

2 Cost Reduction

- KFP series significantly reduces costs comparing with conventional product

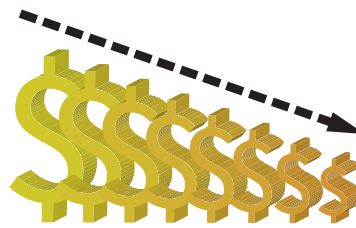

3 High Performance

- High Precision

	Pressure	Flow
Indicator accuracy	± 2 % F.S.	± 3 % F.S.
Repeatability	± 0.2 % F.S.	± 1 % F.S.

- Multiple Output Function

Digital Display	Instantaneous flow value Accumulated flow value Pressure value
Switch Output	NPN output PNP output
Analog output	Voltage output 1~5 V Current output 4~20 mA
Accumulated Pulse Output	50ms pulse output

4 Wide range of applications

- Painting Robot :
Air flow and pressure management of paint and coating processes

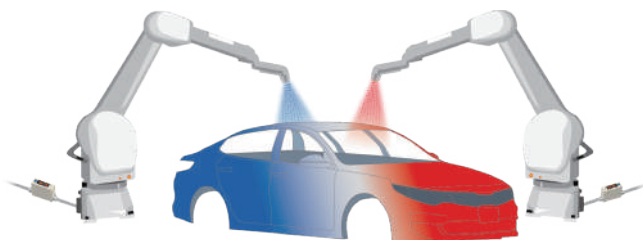

- Reflow Oven / Mounting Machine :
N₂ & Air consumption of the whole equipment management

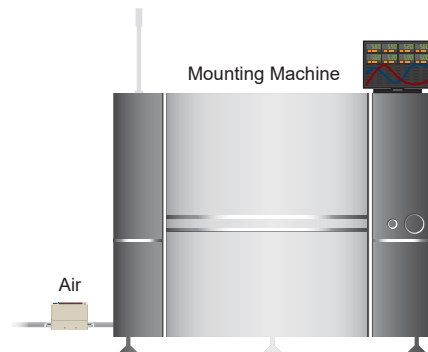

- Laser Welding Robot :
Management of shielding gas, flow rate and pressure

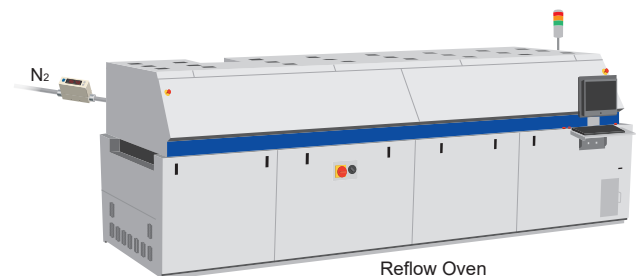
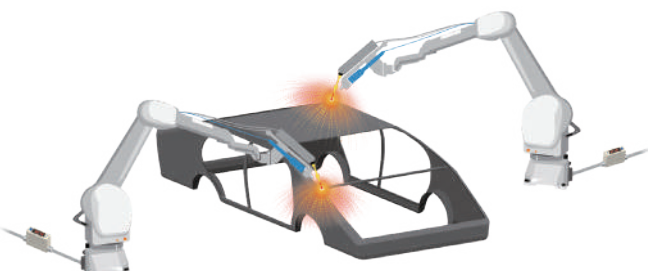



Specifications

Model		005	010	050	100	500	101	201	
Fluid		Dry air, N ₂ , Non-corrosive / Non-flammable gas							
Sensor Element	Flow	Measured Flow Rate Range	0 ~ 500 mL/min	0 ~ 1000 mL/min	0 ~ 5 L/min	0 ~ 10 L/min	0 ~ 50 L/min	0 ~ 100 L/min	0 ~ 200 L/min
	Pressure	Rated Pressure Range	Unidirection						-90 ~ 800 kPa
Display		4 digital * 4 digital, 7 segment LCD display (Red / Green / Orange)							
Instant Flow Rate	Display Range	Minimum	0 ~ 525 mL/min	0 ~ 1050 mL/min	0 ~ 5.25 L/min	0 ~ 10.50 L/min	0 ~ 52.5 L/min	0 ~ 105.0 L/min	0 ~ 210 L/min
		Setting Scale	LPM	1 mL/min	1 mL/min	0.01 L/min	0.01 L/min	0.1 L/min	0.1 L/min
Accumulated Flow	Display Range	Minimum	0.01 ft ³ /min	0.01 ft ³ /min	0.1 ft ³ /min	0.1 ft ³ /min	1 ft ³ /min	1 ft ³ /min	1 ft ³ /min
		Setting Scale	CFM ※1	0.01 ft ³ /min	0.01 ft ³ /min	0.1 ft ³ /min	0.1 ft ³ /min	1 ft ³ /min	1 ft ³ /min
Pressure Display	Display Range	Minimum	99999999 mL	99999999 mL	999999.99 L	999999.99 L	9999999.9 L	9999999.9 L	99999999 L
		Setting Scale	※1	1 mL	1 mL	0.01 L	0.01 L	0.1 L	0.1 L
Accuracy	Flow	Display Range	0.01 ft ³	0.01 ft ³	0.1 ft ³	0.1 ft ³	1 ft ³	1 ft ³	1 ft ³
		Setting Scale	※1	0.01 ft ³	0.01 ft ³	0.1 ft ³	0.1 ft ³	1 ft ³	1 ft ³
Accuracy	Pressure	Display Range	-100 ~ 1000 kPa						
		Setting Scale	kPa	1					
Switch Output	Flow	Guaranteed Range	2 ~ 100 % F.S.						
		Indicator Accuracy	± 3 % F.S. ± 1 digit ※2						
		Analog Output Accuracy	± 5 % F.S. ※2						
		Repeatability	± 1 % F.S. ± 1 digit ※3						
		Linearity	± 3 % F.S. ※3						
	Pressure	Temp. Characteristic	± 2 % F.S. (15 ~ 35 °C) ; ± 5 % F.S. (0 ~ 15 °C, 35 ~ 50 °C) (compare with ※3)						
		Pressure Characteristic	± 5 % F.S. ± 1 digit ※4						
		Guaranteed Range	0 ~ 100 % F.S.						
		Indicator Accuracy	± 2 % F.S. ± 1 digit ※5						
		Analog Output Accuracy	± 2.5 % F.S. ※5						
Analog Output	Response Time	Repeatability	± 0.2 % F.S. ± 1 digit ※5						
		Linearity	± 1 % F.S. ※5						
	Temp. Characteristic	± 2 % F.S. (compare with ※5)							
	Output Mode	Flow	2 NPN : open collector 2 outputs Max. Load Current : 125 mA Max. Supply Voltage : 28 V DC Voltage Drop : ≤ 1.5 V						
		Pressure	2 PNP : open collector 2 outputs Max. Load Current : 125 mA Max. Supply Voltage : 24 V DC Voltage Drop : ≤ 1.5 V						
Hysteresis	Flow	800 ms (50 ms, 80 ms, 120 ms, 200 ms, 400 ms, 1500 ms selectable)							
	Pressure	2.5 ms (25 ms, 100 ms, 250 ms, 500 ms, 1000 ms, 1500 ms selectable)							
Output Short Circuit Protection	Flow	Hysteresis Mode, Window Comparator Mode, Accumulated Output, Accumulated Pulse Output							
	Pressure	One Point Set Mode, Hysteresis Mode, Window Comparator Mode							
Accumulated Pulse Output ※1	Flow	Adjustable							
	Pressure	Yes							
Voltage Output	Flow	5 mL/Pulse	10 mL/Pulse	0.05 L/Pulse	0.1 L/Pulse	0.5 L/Pulse	1 L/Pulse	2 L/Pulse	
	Pressure	0.02 ft ³ /Pulse	0.04 ft ³ /Pulse	0.2 ft ³ /Pulse	0.4 ft ³ /Pulse	2 ft ³ /Pulse	4 ft ³ /Pulse	7 ft ³ /Pulse	
Current Output	Flow	Voltage Output Range : 1 ~ 5 V ※6 Output Impedance : 1 KΩ							
	Pressure	Current Output Range : 4 ~ 20 mA ※6 Load Impedance : ≤ 300 Ω							
Response Time	Flow	Pressure : ≤ 50 ms ; Flow : ≤ 100 ms							
	Pressure	Pressure : ≤ 50 ms ; Flow : ≤ 100 ms							
External Input		Non-voltage input, < 0.4 V, ≥ 30 ms							
Communication Interface		RS485 ※7							
Power	Power Supply Voltage	12 ~ 24 V DC ± 10 %, Ripple (P-P) ≤ 10 %							
	Current Consumption	≤ 50 mA							
Environment	Withstand Pressure	1 MPa							
	Enclosure	IP40							
	Working Fluid Temp.	0 ~ 50 °C (No condensation or freezing)							
	Ambient Temp. Range	Operation : 0 ~ 50 °C ; Storage : -10 ~ 60 °C (No condensation or freezing)							
	Ambient Humidity Range	Operation / Storage : 35 ~ 85 % R.H. (No condensation)							
	Insulation Resistance	≥ 50 MΩ (500 V DC, between case and lead wire)							
	Withstand Voltage	1000 V AC in 1-min (between case and lead wire)							
	Vibration	Total amplitude 1.5 mm or 10 G, 10 Hz ~ 55 Hz ~ 10 Hz scan for 1 minute, 2 hours each direction of X, Y and Z							
Shock	100 m/s ² (10 G), 3 times each in direction of X, Y and Z								
EMC	IEC 61000-6-2, IEC 61000-6-4								
Lead Wire		Ø4 Oil-resistance cable (PVC) - 26 AWG (0.15 mm ²) - 6 cores							
Weight (with 2 Meter Lead Wire)		Approx. 109.3 g (Ø6 port) ; Approx. 112.7 g (Ø8 port) ; Approx. 118 g (Rc1/4" port) ; Approx. 128.5 g (Rc1/8" port)							

NOTE

※1 : CFM (ft³/min*10⁻²) and ft³*10⁻²

※2 : CONDITION : Inlet Pressure : 300 kPa , Outlet Pressure : 1 atmospheric pressure, 25 °C

※3 : CONDITION : Outlet Pressure : 1 atmospheric pressure, 25 °C

※4 : -90 ~ 800 kPa, Outlet Pressure : 1 atmospheric pressure, 25 °C

※5 : Outlet flow rate = 0 L/min, 25 °C

※6 : PWM output, corresponding to pressure sensor 0 ~ 1000 kPa

※7 : This function only available for Output Specification -02 and -04.

Panel Description

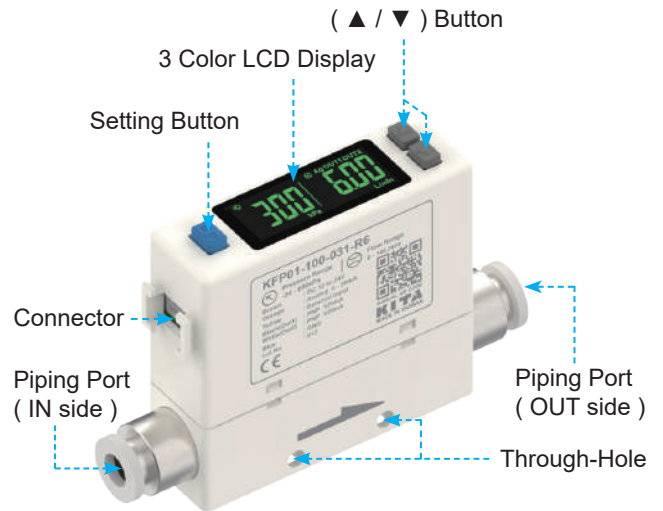
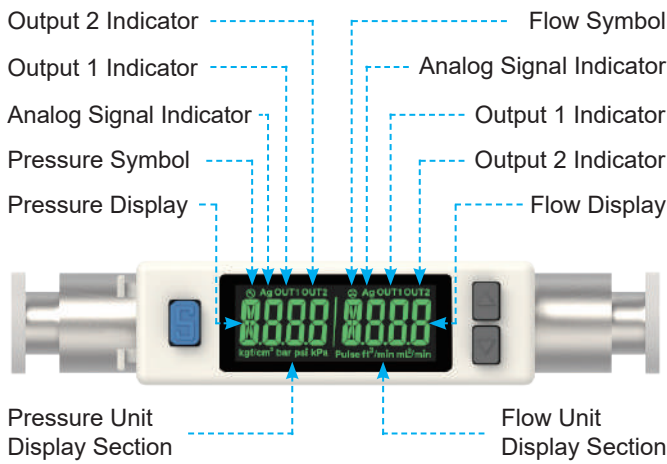

Output Circuit Wiring Diagrams

NPN Output / Analog Voltage Output / External Input

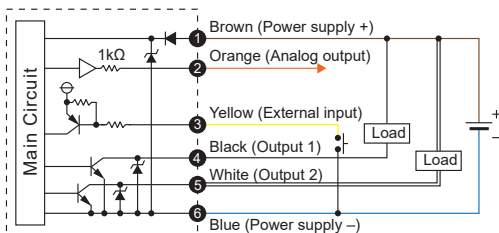

PNP Output / Analog Voltage Output / External Input

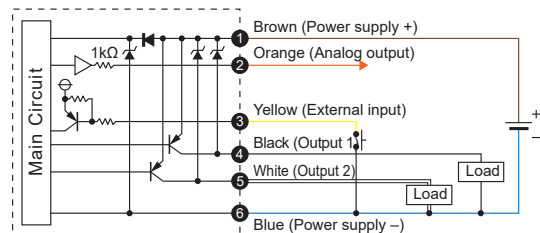

NPN Output / Analog Current Output / External Input

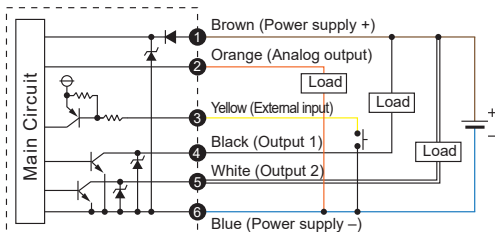

PNP Output / Analog Current Output / External Input

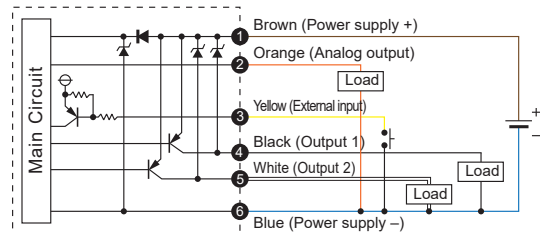

NPN Output / RS485 MODBUS Mode

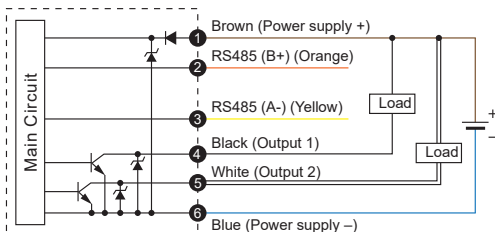

PNP Output / RS485 MODBUS Mode

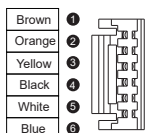
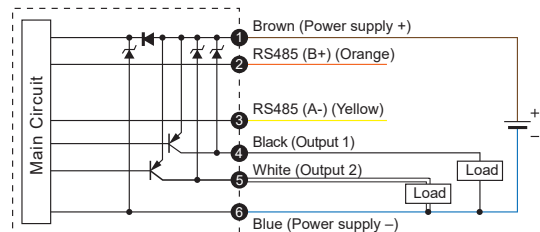

Pin No.	Line color	Content
1	Brown	Power supply (12 ~ 24 V DC)
2	Orange	Analog voltage output : 1 ~ 5 V Analog current output : 4 ~ 20 mA
3	Yellow	RS485 (B+) External input RS485 (A-)
4	Black	Output 1 (Max. load current : 125 mA)
5	White	Output 2 (Max. load current : 125 mA)
6	Blue	0 V (GND)

* Procedure to wiring RS485 products : To prevent product damage due to short circuit , MUST do RS485 line connection BEFORE power line connection.

Ordering Information

K F P 0 1 - 0 0 5 - 0 1 0 - R 6

Flow Rate Range

005 : 500 mL/min
 010 : 1000 mL/min
 050 : 5 L/min
 100 : 10 L/min
 500 : 50 L/min
 101 : 100 L/min
 201 : 200 L/min

Output Specifications

010 : 2 NPN output + Analog output 1 ~ 5 V
 011 : 2 NPN output + Analog output 4 ~ 20 mA
 02 : 2 NPN output + RS485
 030 : 2 PNP output + Analog output 1 ~ 5 V
 031 : 2 PNP output + Analog output 4 ~ 20 mA
 04 : 2 PNP output + RS485

Port Size

R6 : $\varnothing 6$ mm, for Flow Rate Range 005, 010, 050, 100, 500
 R8 : $\varnothing 8$ mm, for Flow Rate Range 101, 201
 F1C : Rc1/8", with internal threads, for Flow Rate Range 005, 010, 050, 100, 500
 F4C : Rc1/4", with internal threads, for Flow Rate Range 101, 201

Optional Parts

BT-26 : Mounting bracket PA-H : Panel adapter + Front protective lid
 PA-G : Panel adapter

Dimensions

Port Size : $\varnothing 6, \varnothing 8$

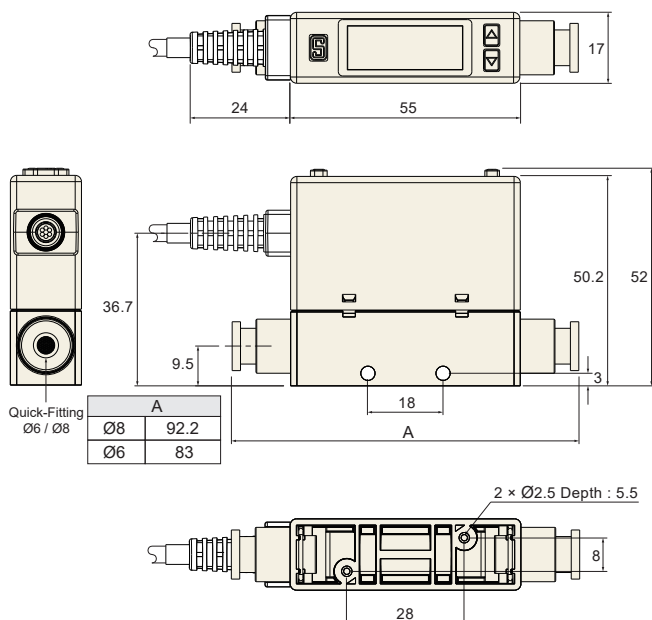

Port Size : Rc1/8", Rc1/4"

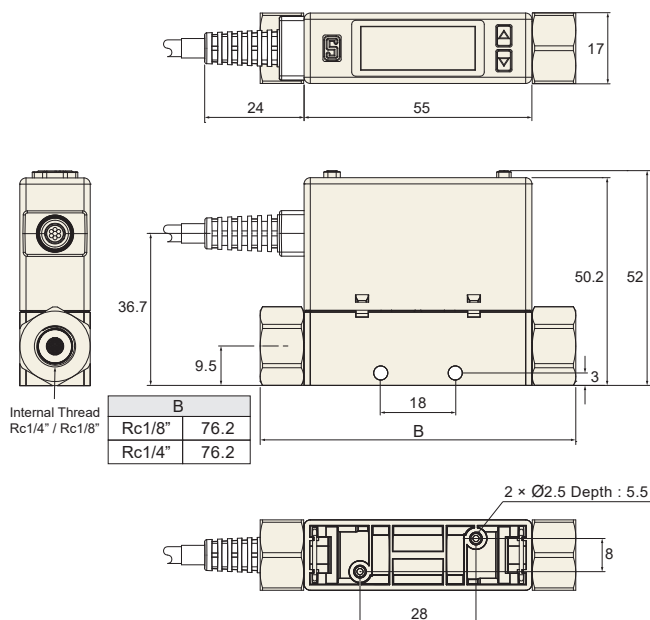

Optional Parts Dimensions

1 Mounting Bracket

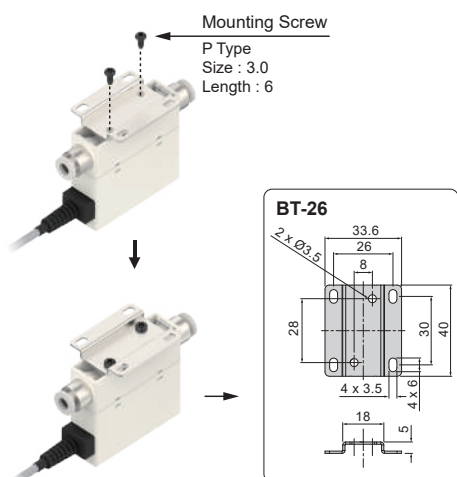

2 Panel Mount Adapter + Front Protective Lid

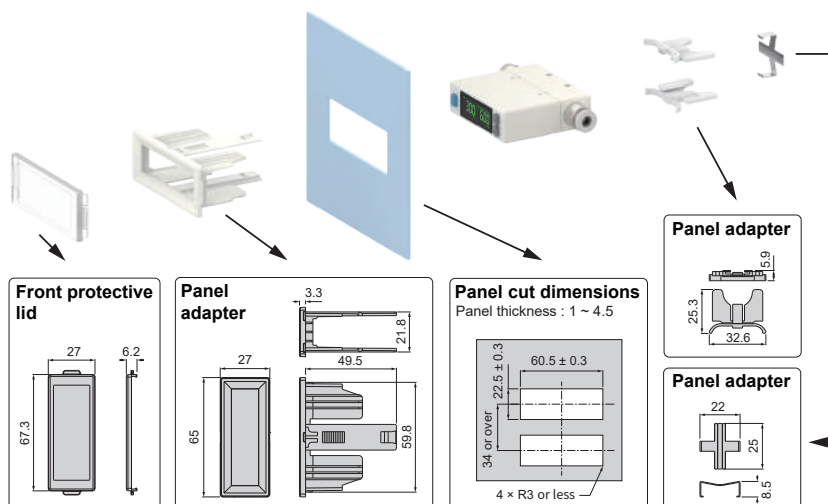

Unit : mm

Features

- Display can be vertically inverted. To set and watch monitor easily
- 7 segment 8 digit LCD display. Accumulated flow rate display at a glance
- Real-time monitoring

RS485 MODBUS CONTROL



Features Highlight

1 3-color LED display

	506	50r	6rn	rEd
ON	Green	Red	Green	Red
OFF	Red	Green	Green	Red

2 Real-time monitoring

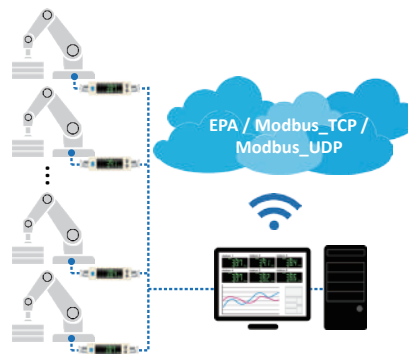

3 High Performance

- High Precision

Indicator accuracy	$\pm 3\%$ F.S.
Repeatability	$\pm 1\%$ F.S.

- Multiple Output Function

Digital Display	Instantaneous flow value Accumulated flow value
Switch Output	NPN output PNP output
Analog output	Voltage output 1~5 V Current output 4~20 mA
Accumulated Pulse Output	50ms pulse output

4 Wide range of applications

- Painting Robot :
Air flow management of paint and coating processes

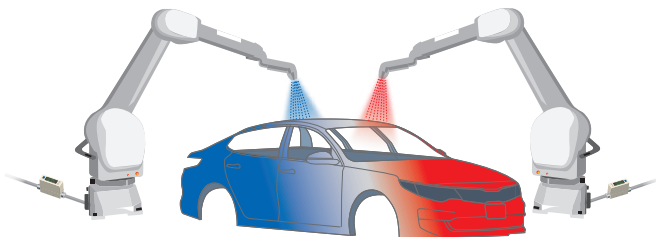

- Reflow Oven / Mounting Machine :
N₂ & Air consumption of the whole equipment management

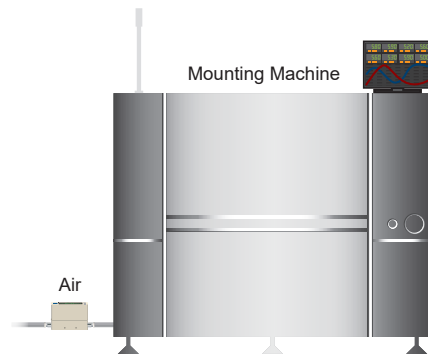

- Laser Welding Robot :
Management of shielding gas, flow rate

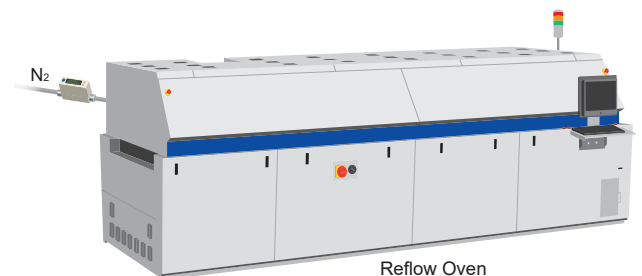
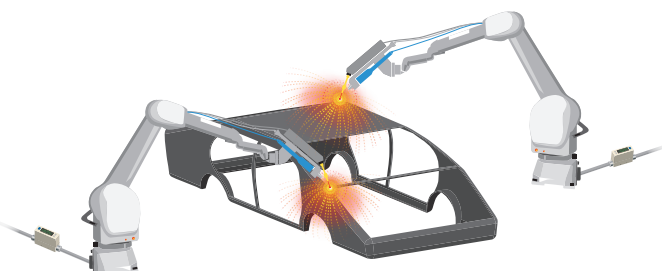

Specifications

Model		005	010	050	100	500	101	201	
Fluid		Dry air, N ₂ , Non-corrosive / Non-flammable gas							
Sensor Element	Measured Flow Rate Range	0 ~ 500 mL/min	0 ~ 1000 mL/min	0 ~ 5 L/min	0 ~ 10 L/min	0 ~ 50 L/min	0 ~ 100 L/min	0 ~ 200 L/min	
	Flow Direction	Unidirection							
		4 digital (Flow) / 8 digital (Accumulated Flow), 7 segment LCD display (Red / Green / Orange)							
Display	Instant Flow Rate	Display Range	0 ~ 525 mL/min	0 ~ 1050 mL/min	0 ~ 5.25 L/min	0 ~ 10.50 L/min	0 ~ 52.5 L/min	0 ~ 105.0 L/min	0 ~ 210 L/min
		Minimum Setting Scale	LPM 1 mL/min	1 mL/min	0.01 L/min	0.01 L/min	0.1 L/min	0.1 L/min	1 L/min
		CFM ※1	0.01 ft ³ /min	0.01 ft ³ /min	0.1 ft ³ /min	0.1 ft ³ /min	1 ft ³ /min	1 ft ³ /min	1 ft ³ /min
	Accumulated Flow	Display Range	99999999 mL	99999999 mL	999999.99 L	999999.99 L	9999999.9 L	9999999.9 L	99999999 L
Minimum Setting Scale ※1		1 mL 0.01 ft ³	1 mL 0.01 ft ³	0.01 L 0.1 ft ³	0.01 L 0.1 ft ³	0.1 L 1 ft ³	0.1 L 1 ft ³	1 L 1 ft ³	
Accuracy	Guaranteed Range	2 ~ 100 % F.S.							
	Indicator Accuracy	± 3 % F.S. ± 1 digit ※2							
	Analog Output Accuracy	± 5 % F.S. ※2							
	Repeatability	± 1 % F.S. ± 1 digit ※3							
	Linearity	± 3 % F.S. ※3							
	Temp. Characteristic	± 2 % F.S. (15 ~ 35 °C) ; ± 5 % F.S. (0 ~ 15 °C, 35 ~ 50 °C) (compare with ※3)							
	Pressure Characteristic	± 5 % F.S. ± 1 digit ※4							
Switch Output		2 NPN : open collector 2 outputs Max. Load Current : 125 mA Max. Supply Voltage : 28 V DC Voltage Drop : ≤ 1.5 V				2 PNP : open collector 2 outputs Max. Load Current : 125 mA Max. Supply Voltage : 24 V DC Voltage Drop : ≤ 1.5 V			
	Response Time	800 ms (50 ms, 80 ms, 120 ms, 200 ms, 400 ms, 1500 ms selectable)							
	Output Mode	Hysteresis Mode, Window Comparator Mode, Accumulated Output, Accumulated Pulse Output							
	Hysteresis	Adjustable							
	Output Short Circuit Protection	Yes							
	Accumulated Pulse Output ※1	5 mL/Pulse 0.02 ft ³ /Pulse	10 mL/Pulse 0.04 ft ³ /Pulse	0.05 L/Pulse 0.2 ft ³ /Pulse	0.1 L/Pulse 0.4 ft ³ /Pulse	0.5 L/Pulse 2 ft ³ /Pulse	1 L/Pulse 4 ft ³ /Pulse	2 L/Pulse 7 ft ³ /Pulse	
Analog Output	Voltage Output	Voltage Output Range : 1 ~ 5 V Output Impedance : 1 KΩ							
	Current Output	Current Output Range : 4 ~ 20 mA Load Impedance : ≤ 300 Ω							
	Response Time	≤ 100 ms							
External Input		Non-voltage input, < 0.4 V, ≥ 30 ms							
Communication Interface		RS485 ※5							
Power	Power Supply Voltage	12 ~ 24 V DC ± 10 %, Ripple (P-P) ≤ 10 %							
	Current Consumption	≤ 50 mA							
Environment	Working Pressure Range	-0.09 ~ 0.8 MPa							
	Withstand Pressure	1 MPa							
	Enclosure	IP40							
	Working Fluid Temp.	0 ~ 50 °C (No condensation or freezing)							
	Ambient Temp. Range	Operation : 0 ~ 50 °C ; Storage : -10 ~ 60 °C (No condensation or freezing)							
	Ambient Humidity Range	Operation / Storage : 35 ~ 85 % R.H. (No condensation)							
	Insulation Resistance	≥ 50 MΩ (500 V DC, between case and lead wire)							
	Withstand Voltage	1000 V AC in 1-min (between case and lead wire)							
	Vibration	Total amplitude 1.5 mm or 10 G, 10 Hz ~ 55 Hz ~ 10 Hz scan for 1 minute, 2 hours each direction of X, Y and Z							
	Shock	100 m/s ² (10 G), 3 times each in direction of X, Y and Z							
EMC	IEC 61000-6-2, IEC 61000-6-4								
Lead Wire		Ø4 Oil-resistance cable (PVC) - 26 AWG (0.15 mm ²) - 6 cores							
Weight (with 2 Meter Lead Wire)		Approx. 109.3 g (Ø6 port) ; Approx. 112.7 g (Ø8 port) ; Approx. 118 g (Rc1/4" port) ; Approx. 128.5 g (Rc1/8" port)							

NOTE

※1 : CFM (ft³/min*10⁻²) and ft³*10⁻²

※4 : -0.09 ~ 0.8 MPa, Outlet Pressure : 1 atmospheric pressure, 25 °C

※2 : CONDITION : Inlet Pressure : 300 kPa , Outlet Pressure : 1 atmospheric pressure, 25 °C ※5 : This function only available for Output Specification -02 and -04.

※3 : CONDITION : Outlet Pressure : 1 atmospheric pressure, 25 °C

Panel Description

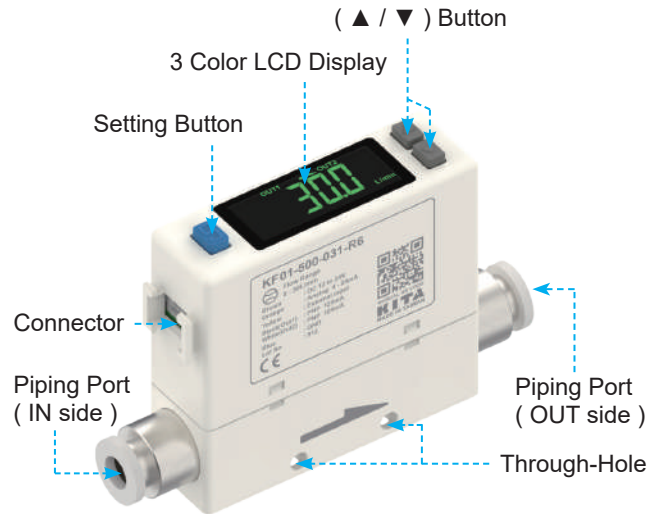
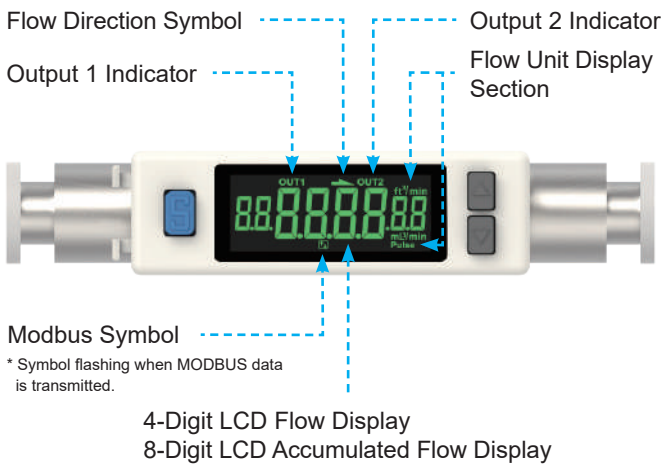

Output Circuit Wiring Diagrams

NPN Output / Analog Voltage Output / External Input

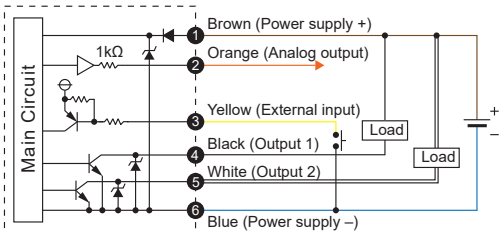

PNP Output / Analog Voltage Output / External Input

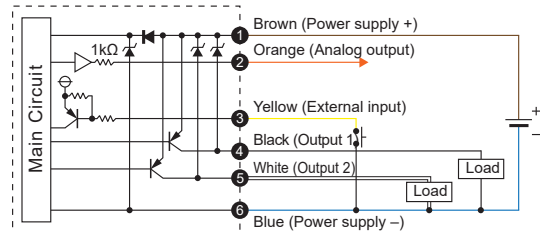

NPN Output / Analog Current Output / External Input

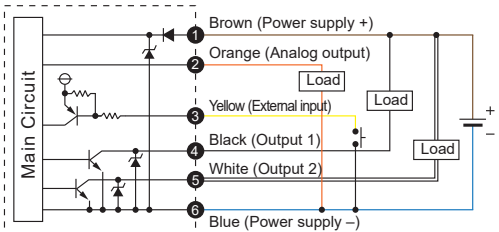

PNP Output / Analog Current Output / External Input

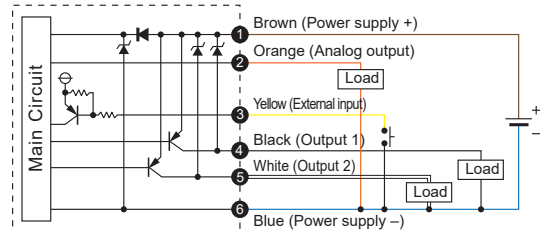

NPN Output / RS485 MODBUS Mode

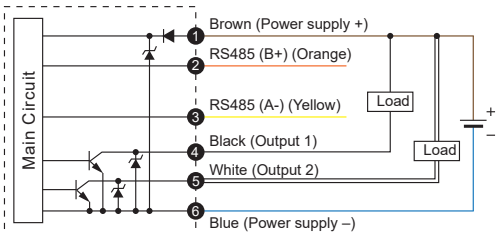

PNP Output / RS485 MODBUS Mode

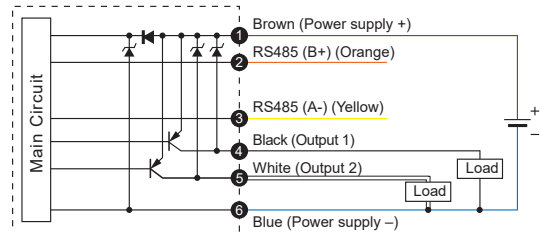

Pin No.	Line color	Content
1	Brown	Power supply (12 ~ 24 V DC)
2	Orange	Analog voltage output : 1 ~ 5 V Analog current output : 4 ~ 20 mA
3	Yellow	External input RS485 (A-)
4	Black	Output 1 (Max. load current : 125 mA)
5	White	Output 2 (Max. load current : 125 mA)
6	Blue	0 V (GND)

* Procedure to wiring RS485 products : To prevent product damage due to short circuit , MUST do RS485 line connection BEFORE power line connection.

Ordering Information

K F 0 1 - 0 0 5 - 0 1 0 - R 6

Flow Rate Range

005 : 500 mL/min
 010 : 1000 mL/min
 050 : 5 L/min
 100 : 10 L/min
 500 : 50 L/min
 101 : 100 L/min
 201 : 200 L/min

Output Specifications

010 : 2 NPN output + Analog output 1 ~ 5 V
 011 : 2 NPN output + Analog output 4 ~ 20 mA
 02 : 2 NPN output + RS485
 030 : 2 PNP output + Analog output 1 ~ 5 V
 031 : 2 PNP output + Analog output 4 ~ 20 mA
 04 : 2 PNP output + RS485

Port Size

R6 : $\varnothing 6$ mm, for Flow Rate Range 005, 010, 050, 100, 500
 R8 : $\varnothing 8$ mm, for Flow Rate Range 101, 201
 F1C : Rc1/8", with internal threads, for Flow Rate Range 005, 010, 050, 100, 500
 F4C : Rc1/4", with internal threads, for Flow Rate Range 101, 201

Optional Parts

BT-26 : Mounting bracket PA-H : Panel adapter + Front protective lid
 PA-G : Panel adapter

Dimensions

Port Size : $\varnothing 6, \varnothing 8$

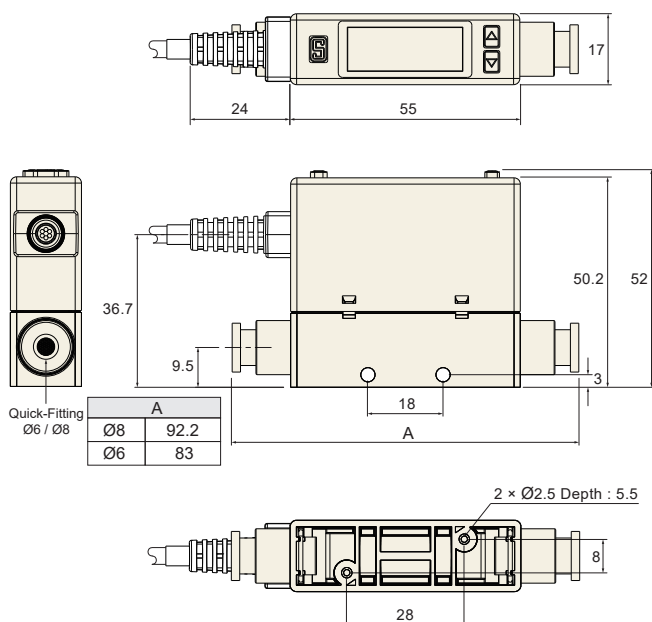

Port Size : Rc1/8", Rc1/4"

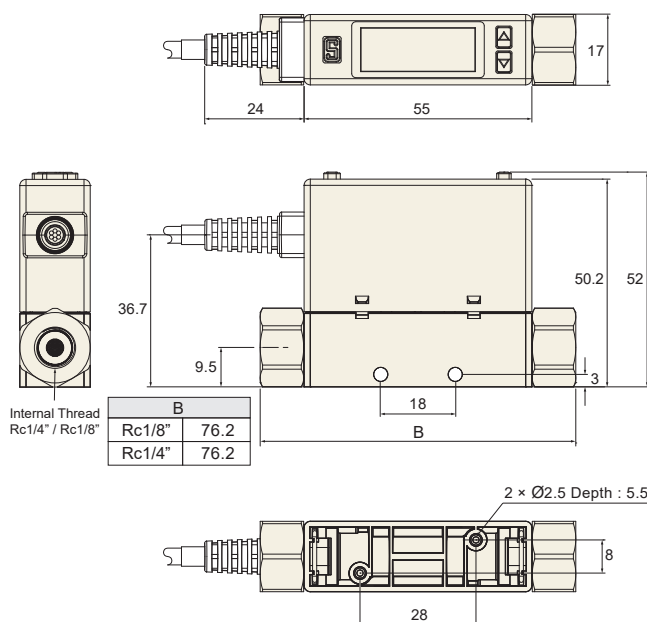

Optional Parts Dimensions

1 Mounting Bracket

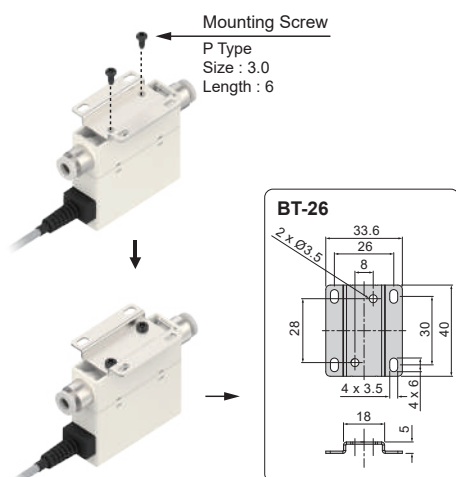

2 Panel Mount Adapter + Front Protective Lid

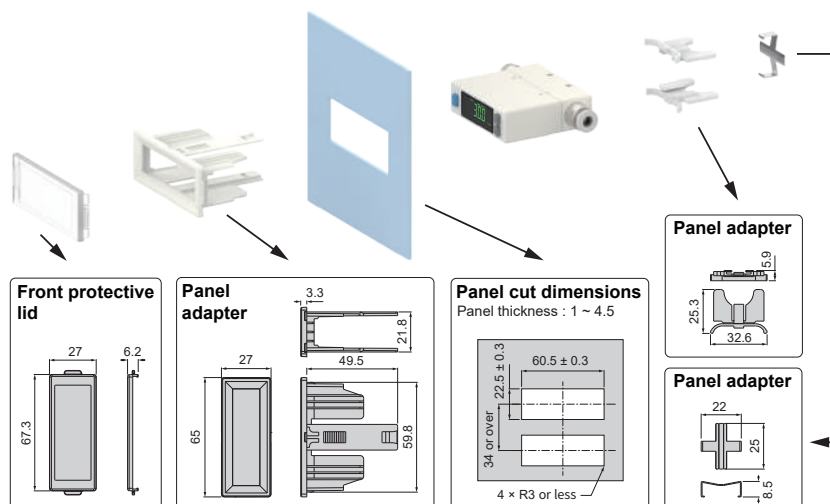

Unit : mm

Magnetic Sensor

KT-05 Series  P.104	KT-06 Series  P.105	KT-07 Series ★  P.106 	KT-09 Series  P.107	KT-11 Series  P.108
KT-13 Series Patented  P.109	KT-15 Series  P.110	KT-16 Series  P.111	KT-20 Series  P.112	KT-21 Series  P.113
KT-31 Series High Temp. Resistant  P.114	KT-32 Series  P.115 	KT-33 Series  P.117	KT-36 Series Compact Size  P.118	KT-37 Series Compact Size  P.119
KT-38 Series Compact Size  P.120	KT-39 Series Compact Size  P.121	KT-40 Series  P.122	KT-47 Series  P.123	KT-48 Series  P.124
KT-50 Series  P.125	KT-53 Series  P.126	KT-58 Series  P.127	KT-59 Series  P.128	KT-65 Series ★ Patented  P.129 
KT-65-EX Series Patented  P.130 	KT-65-UL Series Patented  P.131 	KT-71 Series  P.132	KT-75 Series Patented  P.133	KT-77 Series  P.134
KT-1000D Series Magnetic-Field Resistant  P.135	KT-1001D Series Magnetic-Field Resistant  P.137	Bracket  P.138	Clamp  P.142	Magnet  P.148

※ Product surfaces with slight luminance non-uniformity, color cast, tiny scratching, little stains etc. are regarded as qualified products.

Ordering Information

K T - **06RH** - **1M**

Sensor Model

Sensor Type

R = Reed switch 2-wire type
 RP = Reed switch 3-wire current sourcing
 RN = Reed switch 3-wire current sinking
 P = Solid state type, current sourcing (PNP output)
 N = Solid state type, current sinking (NPN output)
 D = Solid state type, 2-wire
 T = TRIAC output
 R - NC = REED / N. C
 P - NC = PNP / N. C
 N - NC = NPN / N. C

Special Mark

None = Standard sensitivity
 H = High sensitivity
 HH = Ultra high sensitivity
 L = Low sensitivity
 LL = Ultra low sensitivity
 X = No indicator

Cable Length / QD Pinout

QD = M8 male connector
 EQD = M8 male connector
 1M = The length of cable is 1 meter
 2M = The length of cable is 2 meters
 3M = The length of cable is 3 meters
 5M = The length of cable is 5 meters
 10M = The length of cable is 10 meters

Connection Method

1 2 Wire Sensor Connection

General Connection (Reed Switch)

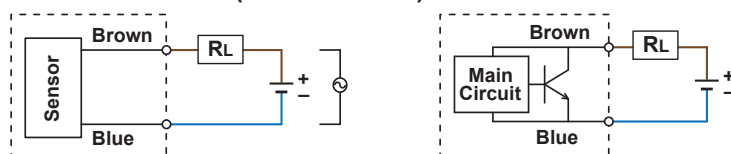

(PLC)

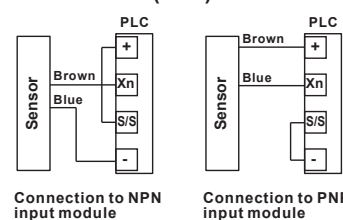

Series Connection (AND)

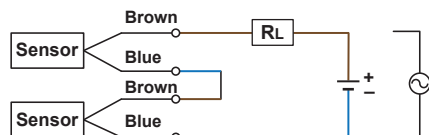

Parallel Connection (OR)

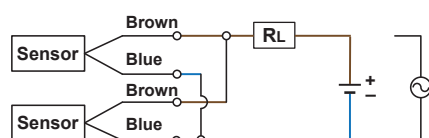

When connecting 2-wire sensors in series (AND), don't exceed more than two sensors due to the internal voltage drop (Typical V drop = 2.5 ~ 4 V per switch). Excessive Voltage drop will cause non-operation of the load.

- When connecting solid state 2-wire sensors in parallel (OR), leakage current will increase and cause improper load operation.
- When connecting 2-wire reed sensors in parallel (OR), possible concurrent operation will cause dim LED illumination due to lower current distribution.

2 3 Wire NPN Connection

General Connection

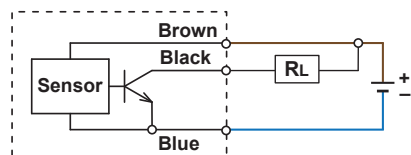

Series Connection (AND)

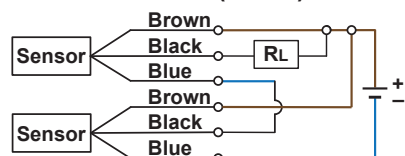

Parallel Connection (OR)

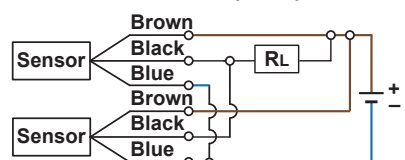



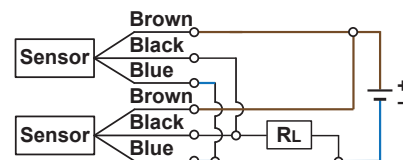
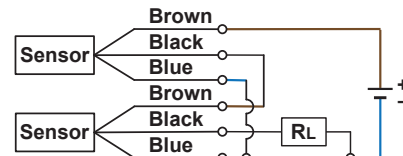
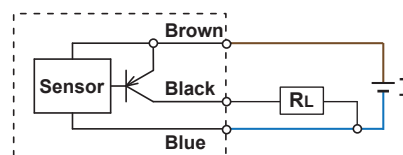



3 3 Wire PNP Connection

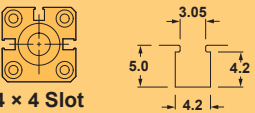
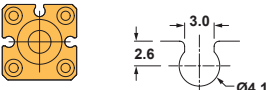
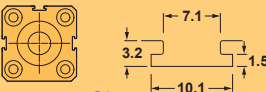

Cylinder / Magnetic SW. Cross Index

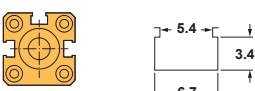
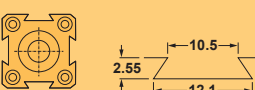

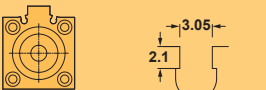
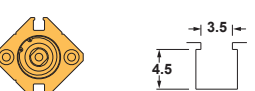
MODEL	KT-05	KT-06	KT-07	KT-09	KT-11	KT-13	KT-15	KT-16	KT-20	KT-21	KT-31	KT-32 KT-32-EX	KT-33
Round Cylinder 	● BK Clamp P.143		● BKC-1 Clamp P.145				● BK Clamp P.143		● PN / PH Clamp P.142	● PN / PH Clamp P.142			
ISO Profile Cylinder 			● PF7 Bracket P.140					● PF7 Bracket P.140	● PI Bracket P.138	● PI Bracket P.138	● PI Bracket P.138	● PF Bracket P.139	
Tie-Rod Cylinder 			● DT7 Bracket P.140	●		●		● DT7 Bracket P.140	● PM Bracket P.138	● PM Bracket P.138	● PM Bracket P.138	● DT Bracket P.139 FST Clamp P.147	
 4 x 4 Slot		●											
 SMC C Slot			●					●					
 KOGANEI T Slot				●									
 SMC T Slot													●
 SMC T Slot													●
 FESTO T Slot			● PB Bracket P.141					● PB Bracket P.141				●	
 Dovetail Slot													
 SMC T Slot			● PB Bracket P.141					● PB Bracket P.141					
 FESTO C Slot													
 AIRTAC 4 x 4 Slot													

※ Figures above are for reference only; sizes will vary according to individual cylinder manufacturer.



KT-36	KT-37	KT-38	KT-39	KT-40	KT-47	KT-48	KT-50	KT-53	KT-58	KT-59	KT-65 KT-65-EX KT-65-UL	KT-71	KT-75	KT-77	KT-1000D	KT-1001D
BKC-1 Bracket P.145				BL-1 Clamp P.144		BS Clamp P.143	BL-1 Clamp P.144				BKT-1 Clamp P.146		BKT-1 Clamp P.146	BKC-1 Clamp P.145	BP Clamp P.136 PMB Bracket P.136	
PF7 Bracket P.140	PF7 Bracket P.140	PF7 Bracket P.140	PF7 Bracket P.140	PF Bracket P.139			PF Bracket P.139				PF Bracket P.139		PF Bracket P.149	PF7 Bracket P.140		
DT7 Bracket P.140	DT7 Bracket P.140	DT7 Bracket P.140	DT7 Bracket P.140	DT Bracket P.139 FST Clamp P.147			DT Bracket P.139 FST Clamp P.147				DT Bracket P.139 FST Clamp P.147		DT Bracket P.139 FST Clamp P.147	DT7 Bracket P.140		
																PB Bracket P.141
PB Bracket P.141	PB Bracket P.141	PB Bracket P.141	PB Bracket P.141											PB Bracket P.141		PB Bracket P.141

Magnetic Sensor Operating & Installing

Reed SW. Type

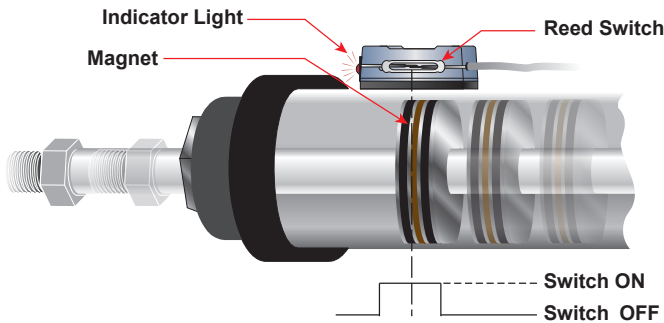

When the piston's magnet approaches the magnetic sensor, the internal reed switch will detect the change of magnetic field and close the contacts.

Solid State Type

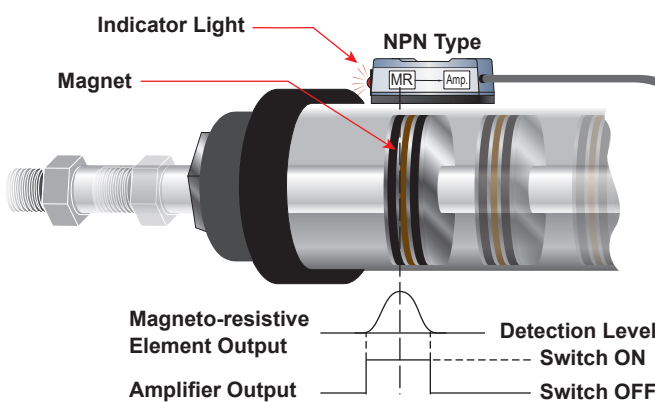

MODEL : TS-2

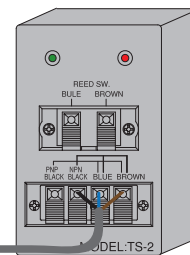

When the piston's magnet approaches the magnetic sensor, the internal magneto-resistive element can detect the change of magnetic field and cause a tiny voltage change. Switching output is achieved when this signal is amplified by the operation amplifier circuit in the magnetic sensor.

How To Install The Magnetic Sensor

1 End Of Stroke Detection

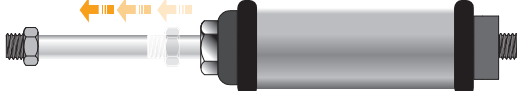
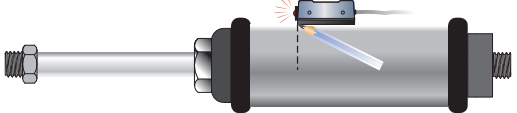
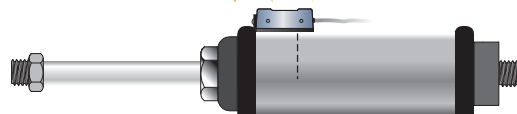
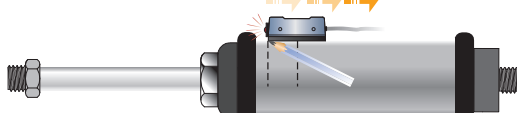
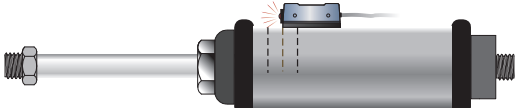
- STEP 1 : Set the piston to the end of stroke position.
 
- STEP 2 : Slide the magnetic sensor forward and keep it close to the cylinder wall. Make a mark at the sensor turn-on point.
 
- STEP 3 : Slide the sensor forward continuously until the sensor turns off.
 
- STEP 4 : Slide the sensor backward until the sensor turns back on and make a mark.
 
- STEP 5 : The intermediate position between the 2 marks will be the most ideal position.
 

2 Intermediate Stroke Position

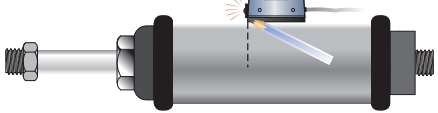
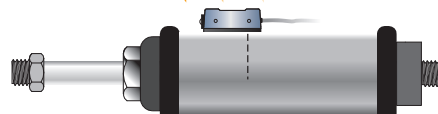
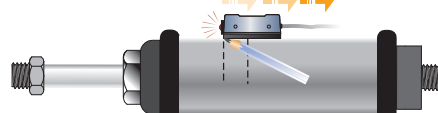
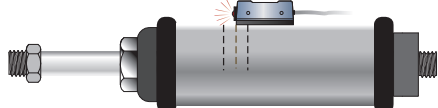
- STEP 1 : Set the piston to the required position.
 
- STEP 2 : Slide the magnetic sensor forward and keep it close to the cylinder wall. Make a mark at the sensor turn-on point.
 
- STEP 3 : Slide the sensor forward continuously until the sensor turns off.
 
- STEP 4 : Slide the sensor backward until the sensor turns back on and make a mark.
 
- STEP 5 : The intermediate position between the 2 marks will be the most ideal position.
 

Caution

1 Do not exceed specification, permanent damage to the sensor may occur.

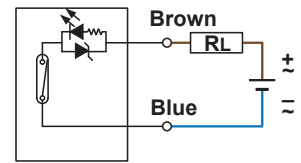

2 For reed sensor type sensors, polarity must also be observed for the proper function of LED. Connect the brown wire in series with load to positive (+) and the blue wire to negative (-) of power source. If the polarity is reversed, reed sensor remain functional but LED will remain in " OFF " state.

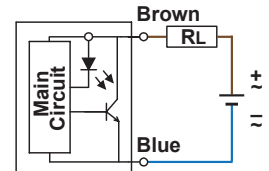

3 For solid-state type sensors, polarity must also be observed. Connect brown wire to the positive (+) and the blue to the negative (-) of DC power source. The black wire must connect to the load only. If the black wire is accidentally connected to the power source, permanent damage to the sensor may occur.

(NPN Output)

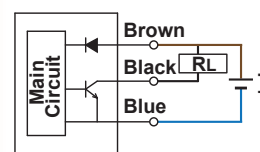

(PNP Output)

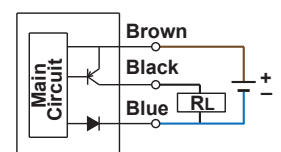

4 An external protection circuit may be required if the magnetic sensor is used with inductive load, such as relay or solenoid. For DC inductive load, attach an external diode parallel to the load and use R-C circuit parallel with AC inductive load as illustrated below.

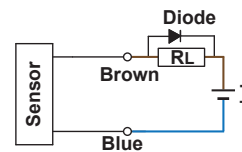

$$C = I^2/10 \text{ [}\mu\text{F]}$$

$$R = E/10 \text{ [}(1+50/E)\text{]} \text{ [}\Omega\text{]}$$

PS:

C : Capacitor

I : Load current

R : Resistance

E : AC power

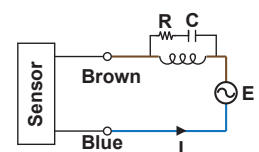

5 Keep sensors away from strong magnetic field to prevent malfunctions.

6 Reed sensors are without protection circuit. When a reed sensor is used with a capacitive load or with more than 5 meters lead wire, the life of the contact will be shortened. (especially when the switch is always ON)
Note : Please install a surge suppressor SR-1 within 1 meter or an inductor (560 ~ 1000 μH) in series of the sensor to prevent damage.

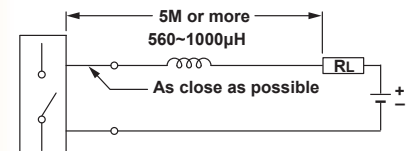

■ MODEL : SR-1 (Surge Suppressor)

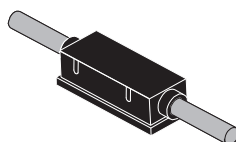
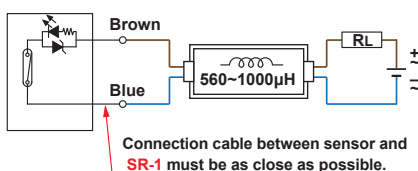

■ Dimension

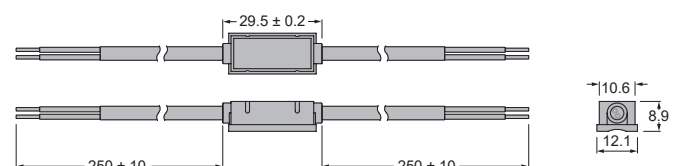

Unit : mm

Hot Sale

Product Integration

KT-07 & KT-16 Series



- Fits in most C-slot cylinder, replace all other T-slot sensors, and reducing your inventory.



Common Cylinder Slot Dimensions

※ C-slot cylinder dimensions

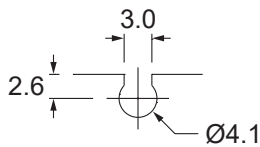

※ T-slot cylinder dimensions

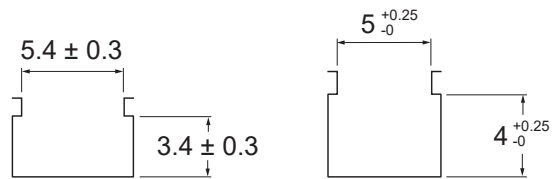

Mounting Adapter for Other Cylinder Types

- Applied to many kind of cylinders.

PF7 bracket mount with ISO profile cylinder

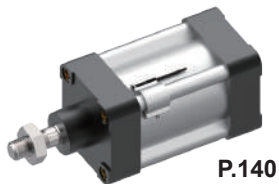

P.140

BKC-1 clamp mount with round cylinder



P.145

C-slot cylinder



KT-07 P.106
KT-16 P.111

DT7 bracket mount with Tie-Rod cylinder



P.140

PB bracket mount with T-slot cylinder



P.141



KT-07 & KT-16 Series

New Structure

KT-65 & KT-75 Series

- Set-screw near center position to prevent sensor from moving, combined with new set-screw design to provide solid stance when attached to the cylinder.

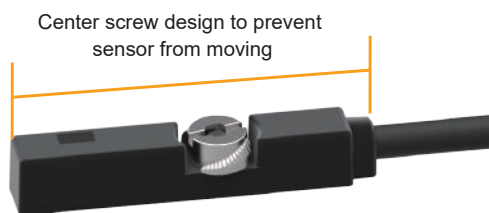

- Fits in most T-slot cylinder, replace all other T-slot sensors, reducing inventory items.



Quick Installation

- Install sensor from top of cylinder, directly placed into T-slot to achieve quick installation.

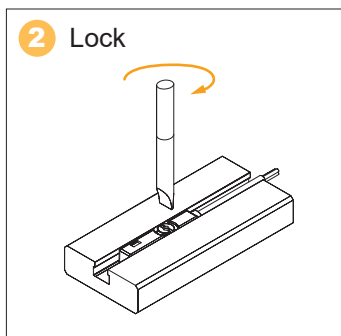
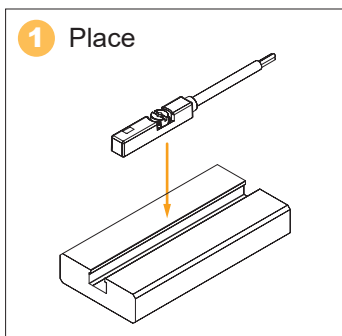

※ T-slot cylinder dimensions

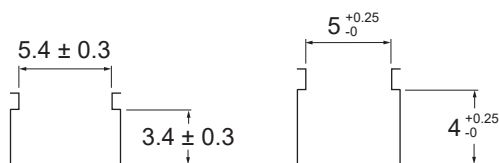

Mounting Adapter for Other Cylinder Types

- Applied to many kind of cylinders.

PF bracket mount with ISO profile cylinder



FST clamp mount with Tie-Rod cylinder



BKT-1 clamp mount with round cylinder



DT bracket mount with Tie-Rod cylinder



T-slot cylinder



KT-65 & KT-75 Series

KT-05 SERIES



Dimensions

KT-05R, KT-05D, KT-05DE, KT-05N, KT-05NE,
KT-05P, KT-05PE /
KT-05R-QD, KT-05D-QD, KT-05DE-QD, KT-05N-QD,
KT-05NE-QD, KT-05P-QD, KT-05PE-QD

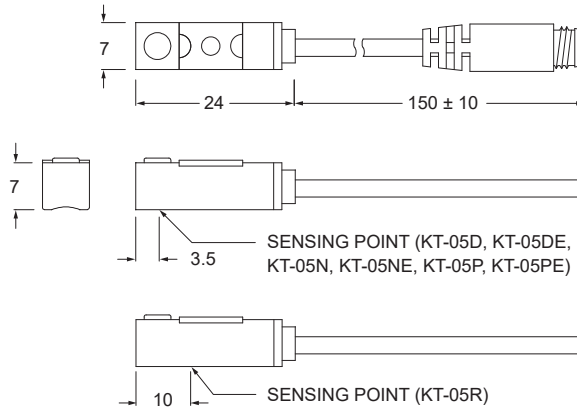

Unit : mm

QD Pinout

- **3 wire QD wiring**
- **2 wire QD wiring**
- **2 wire EQD wiring**

Specifications

MODEL	KT-05R	KT-05D	KT-05DE	KT-05N	KT-05NE	KT-05P	KT-05PE
Connect Diagram							
Characteristics	2-Wire type			3-Wire type			
Wiring Method	2-Wire type			3-Wire type			
Switching Logic	SPST, Normally Open			Solid State Output, Normally Open			
Sensor Type	Reed Switch			NPN Current Sinking		PNP Current Sourcing	
Operating Voltage	5 ~ 240 V DC / AC			10 ~ 28 V DC			
Switching Current	100 mA max.			50 mA max.			
Contact Rating ※1	10 W max.			1.5 W max.			
Current Consumption	-			8 mA @ 24 V DC max.			
Voltage Drop	3.5 V max.			3.7 V max.			
Leakage Current	-			0.1 mA (40 uA) max.			
Indicator	Red LED					Green LED	
Cable	Ø2.8 PVC - 26 AWG (0.15 mm ²) - 2 cores			Ø2.8 PVC - 24 AWG (0.22 mm ²) - 3 cores			
Operating Frequency	200 Hz			1000 Hz max.			
Magnet Requirement ※2	55 Gauss			80 Gauss		40 ~ 1000 Gauss	
Temperature Range	-10 ~ 70 °C						
Shock ※3	30 G			50 G			
Vibration ※4	9 G						
Enclosure Classification	IEC 60529 IP67						
Protection Circuit ※5	1	2, 4		3, 4		2, 3, 4	

NOTE

- ※1 : WARNING : Never exceed rating (Watt = Voltage x Amperage). Permanent damage to sensor will occur.
- ※2 : Measuring standard target : Ø15.5 × Ø8 × 5t (Anisotropy rubber magnet)
- ※3 : Sin wave / X , Y , Z 3 directions / 3 times each direction / 11 ms each time.
- ※4 : Double amplitude 1.5 mm / 10 Hz ~ 55 Hz ~ 10 Hz (Sweep 1 min) / X , Y , Z 3 directions / 1 hour each time.
- ※5 : 1 = None / 2 = Short-circuit / 3 = Power Source Reverse polarity / 4 = Surge Suppression

Clamps

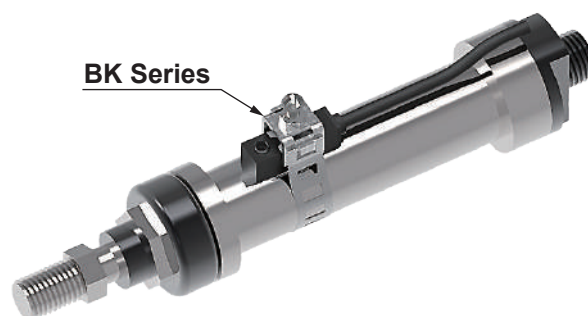
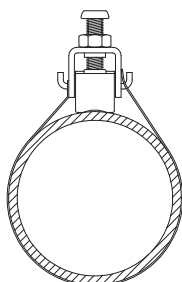

KT-06 SERIES



Dimensions

KT-06R, KT-062R, KT-06D, KT-06DE, KT-06N, KT-06NE,
KT-06P, KT-06PE /
KT-06R-QD, KT-062R-QD, KT-06D-QD, KT-06DE-QD,
KT-06N-QD, KT-06NE-QD, KT-06P-QD, KT-06PE-QD

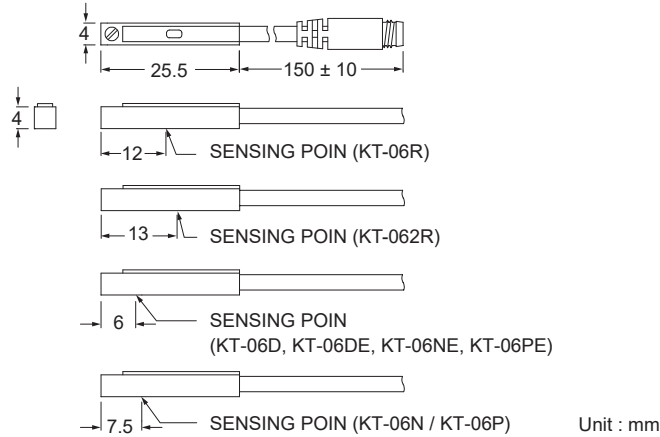

QD Pinout

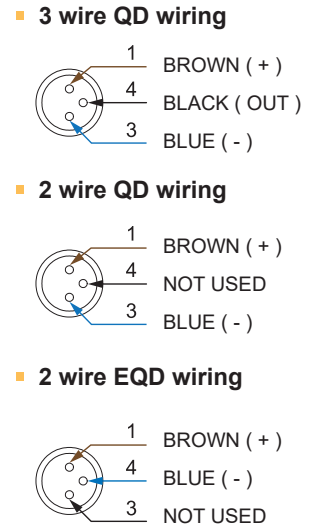

Specifications

MODEL	KT-06R	KT-062R	KT-06D	KT-06DE	KT-06N	KT-06NE	KT-06P	KT-06PE
Connect Diagram								
Characteristics								
Wiring Method	2-Wire Type				3-Wire Type			
Switching Logic	SPST, Normally Open				Solid State Output, Normally Open			
Sensor Type	Reed Switch		-		NPN Current Sinking		PNP Current Sourcing	
Operating Voltage	5 ~ 120 V DC / AC	5 ~ 240 V DC / AC	10 ~ 28 V DC		5 ~ 30 V DC			
Switching Current	100 mA max.		4 ~ 40 mA max.	50 mA max.	200 mA max.			
Contact Rating ※1	10 W max.		1.1 W max.	1.5 W max.	6 W max.			
Current Consumption	-				8 mA @ 24 V DC max.	6 mA @ 24 V DC max.	8 mA @ 24 V DC max.	6 mA @ 24 V DC max.
Voltage Drop	3.5 V max.			3.7 V max.	1 V @ 200 mA max.	0.5 V @ 200 mA max.	1 V @ 200 mA max.	0.5 V @ 200 mA max.
Leakage Current	-		1 mA max.	0.1 mA (40 uA) max.	0.01 mA max.			
Indicator	Red LED	Green LED	Red LED				Green LED	
Cable	Ø2.8 PUR - 26 AWG (0.15 mm ²) - 2 cores				Ø2.8 PUR - 26 AWG (0.15 mm ²) - 3 cores			
Operating Frequency	200 Hz		1000 Hz max.					
Magnet Requirement ※2	70 Gauss		40 Gauss	40 ~ 1000 Gauss	40 Gauss	40 ~ 1000 Gauss	40 Gauss	40 ~ 1000 Gauss
Temperature Range	-10 ~ 70 °C							
Shock ※3	30 G		50 G					
Vibration ※4	9 G							
Enclosure Classification	IEC 60529 IP67							
Protection Circuit ※5	1		4	3, 4	2, 3, 4	3, 4	2, 3, 4	3, 4

NOTE

※1 : WARNING : Never exceed rating (Watt = Voltage x Amperage). Permanent damage to sensor will occur.

※2 : Measuring standard target : Ø15.5 × Ø8 × 5t (Anisotropy rubber magnet)

※3 : Sin wave / X , Y , Z 3 directions / 3 times each direction / 11 ms each time.

※4 : Double amplitude 1.5 mm / 10 Hz ~ 55 Hz ~ 10 Hz (Sweep 1 min) / X , Y , Z 3 directions / 1 hour each time.

※5 : 1 = None / 2 = Short-circuit / 3 = Power Source Reverse polarity / 4 = Surge Suppression

Groove Dimensions

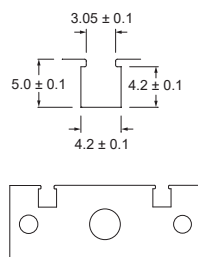

Unit : mm

KT-07 SERIES



Dimensions

KT-07R, KT-072R, KT-07D, KT-07DE, KT-07N, KT-07NE,
KT-07P, KT-07PE /
KT-07R-QD, KT-072R-QD, KT-07D-QD, KT-07DE-QD,
KT-07N-QD, KT-07NE-QD, KT-07P-QD, KT-07PE-QD

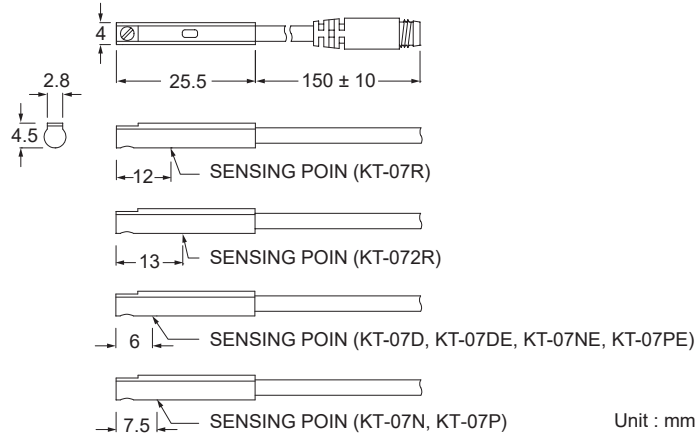

Unit : mm

QD Pinout

3 wire QD wiring

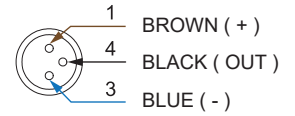

2 wire QD wiring

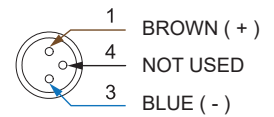

2 wire EQD wiring

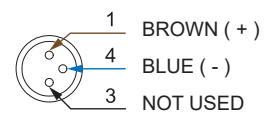

Specifications

MODEL	KT-07R	KT-072R	KT-07D	KT-07DE	KT-07N	KT-07NE	KT-07P	KT-07PE
Connect Diagram								
Characteristics								
Wiring Method	2-Wire Type				3-Wire Type			
Switching Logic	SPST, Normally Open				Solid State Output, Normally Open			
Sensor Type	Reed Switch		-		NPN Current Sinking		PNP Current Sourcing	
Operating Voltage	5 ~ 120 V DC / AC	5 ~ 240 V DC / AC	10 ~ 28 V DC		5 ~ 30 V DC			
Switching Current	100 mA max.		4 ~ 40 mA max.	50 mA max.	200 mA max.			
Contact Rating ※1	10 W max.		1.1 W max.	1.5 W max.	6 W max.			
Current Consumption	-		-		8 mA @ 24 V DC max.	6 mA @ 24 V DC max.	8 mA @ 24 V DC max.	6 mA @ 24 V DC max.
Voltage Drop	3.5 V max.		3.7 V max.		1 V @ 200 mA max.	0.5 V @ 200 mA max.	1 V @ 200 mA max.	0.5 V @ 200 mA max.
Leakage Current	-		1 mA max.	0.1 mA (40 uA) max.	0.01 mA max.			
Indicator	Red LED	Green LED	Red LED		Green LED			
Cable	Ø2.8 PUR - 26 AWG (0.15 mm ²) - 2 cores				Ø2.8 PUR - 26 AWG (0.15 mm ²) - 3 cores			
Operating Frequency	200 Hz		1000 Hz max.					
Magnet Requirement ※2	70 Gauss		40 Gauss	40 ~ 1000 Gauss	40 Gauss	40 ~ 1000 Gauss	40 Gauss	40 ~ 1000 Gauss
Temperature Range	-10 ~ 70 °C							
Shock ※3	30 G		50 G					
Vibration ※4	9 G							
Enclosure Classification	IEC 60529 IP67							
Protection Circuit ※5	1		4	3, 4	2, 3, 4	3, 4	2, 3, 4	3, 4

NOTE

※1 : WARNING : Never exceed rating (Watt = Voltage x Amperage).
Permanent damage to sensor will occur.

※2 : Measuring standard target : Ø15.5 × Ø8 × 5t (Anisotropy rubber magnet)

※3 : Sin wave / X , Y , Z 3 directions / 3 times each direction / 11 ms each time.

※4 : Double amplitude 1.5 mm / 10 Hz ~ 55 Hz ~ 10 Hz (Sweep 1 min) / X , Y , Z 3 directions / 1 hour each time.

※5 : 1 = None / 2 = Short-circuit / 3 = Power Source Reverse polarity / 4 = Surge Suppression

Groove Dimensions

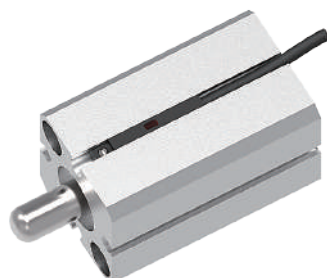
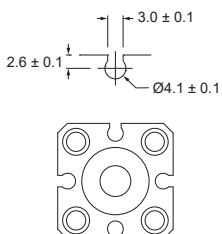

Bracket

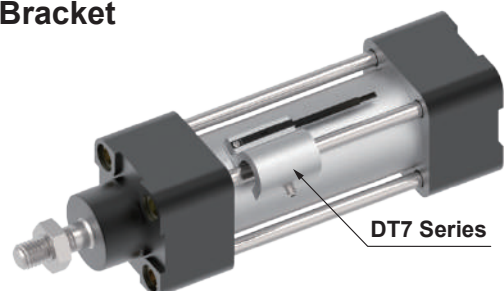

DT7 Series

Unit : mm

KT-09 SERIES



Dimensions

KT-09R, KT-09N, KT-09P /
KT-09R-QD, KT-09N-QD, KT-09P-QD

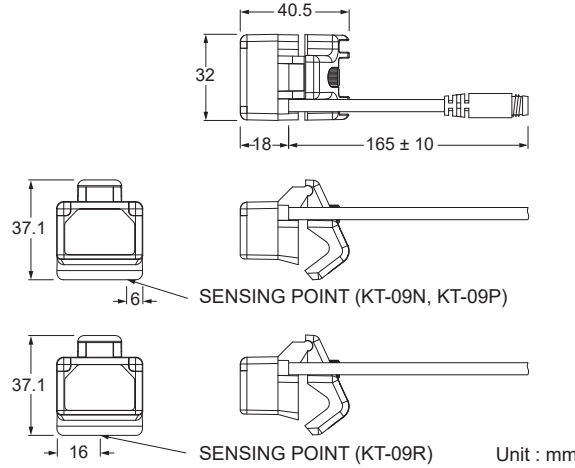

QD Pinout

- 3 wire QD wiring
 - 1 BROWN (+)
 - 4 BLACK (OUT)
 - 3 BLUE (-)
- 2 wire QD wiring
 - 1 BROWN (+)
 - 4 NOT USED
 - 3 BLUE (-)
- 2 wire EQD wiring
 - 1 BROWN (+)
 - 4 BLUE (-)
 - 3 NOT USED

Specifications

MODEL	KT-09R	KT-09N	KT-09P
Connect Diagram			
Characteristics			
Wiring Method	2-Wire Type	3-Wire Type	
Switching Logic	SPST, Normally Open	Solid State Output, Normally Open	
Sensor Type	Reed Switch	NPN Current Sinking	PNP Current Sourcing
Operating Voltage	5 ~ 240 V DC / AC	5 ~ 30 V DC	
Switching Current		1 Amp. max.	
Contact Rating ※1		30 W max.	
Current Consumption	-	42 mA @ 24 V DC max.	30 mA @ 24 V DC max.
Voltage Drop	3.5 V max.	1.5 V @ 0.5 A max.	
Leakage Current	-	0.01 mA max.	
Indicator	Red LED	Power : Green LED , Output : Red LED	
Cable	Ø4.5 PVC - 24 AWG (0.22 mm ²) - 2 cores	Ø4.5 PVC - 24 AWG (0.22 mm ²) - 3 cores	
Operating Frequency	200 Hz	1000 Hz	
Magnet Requirement ※2	80 Gauss	40 Gauss	
Temperature Range		-10 ~ 70°C	
Shock ※3	30 G	50 G	
Vibration ※4		9 G	
Enclosure Classification		IEC 60529 IP67	
Protection Circuit ※5	4	3, 4	

NOTE

※1 : WARNING : Never exceed rating (Watt = Voltage x Amperage).
Permanent damage to sensor will occur.

※2 : Measuring standard target : Ø15.5 × Ø8 × 5t (Anisotropy rubber magnet)

※3 : Sin wave / X , Y , Z 3 directions / 3 times each direction / 11 ms each time.

※4 : Double amplitude 1.5 mm / 10 Hz ~ 55 Hz ~ 10 Hz (Sweep 1 min) / X , Y , Z 3 directions / 1 hour each time.

※5 : 1 = None / 2 = Short-circuit / 3 = Power Source Reverse polarity / 4 = Surge Suppression

Clamps

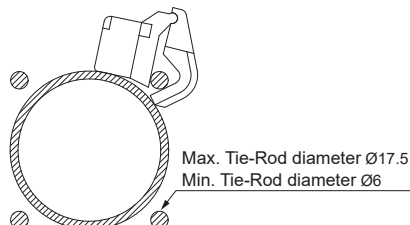

Unit : mm

KT-11 SERIES



Dimensions

KT-11R, KT-11D, KT-11DE, KT-11N, KT-11NE, KT-11P, KT-11PE /
KT-11R-QD, KT-11D-QD, KT-11DE-QD, KT-11N-QD, KT-11NE-QD,
KT-11P-QD, KT-11PE-QD

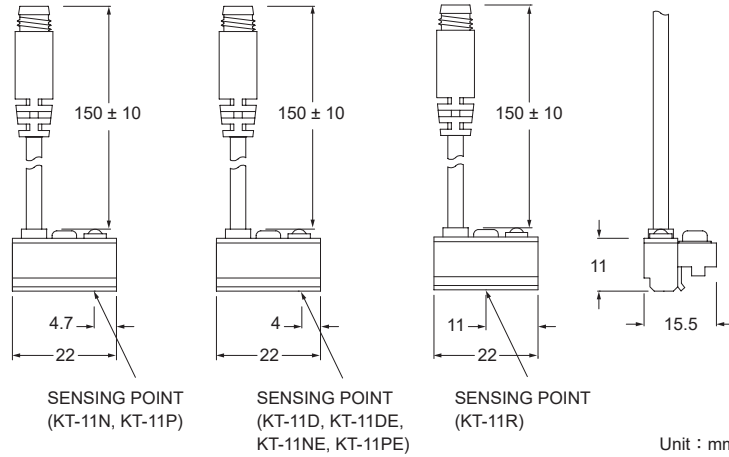

QD Pinout

- 3 wire QD wiring**
 - 1 BROWN (+)
 - 4 BLACK (OUT)
 - 3 BLUE (-)
- 2 wire QD wiring**
 - 1 BROWN (+)
 - 4 NOT USED
 - 3 BLUE (-)
- 2 wire EQD wiring**
 - 1 BROWN (+)
 - 4 BLUE (-)
 - 3 NOT USED

Specifications

MODEL	KT-11R	KT-11D	KT-11DE	KT-11N	KT-11NE	KT-11P	KT-11PE
Connect Diagram							
Characteristics	2-Wire type			3-Wire type			
Wiring Method	2-Wire type			3-Wire type			
Switching Logic	SPST, Normally Open			Solid State Output, Normally Open			
Sensor Type	Reed Switch			-		NPN Current Sinking	
Operating Voltage	5 ~ 240 V DC / AC			10 ~ 28 V DC			
Switching Current	100 mA max.			4 ~ 40 mA max.			
Contact Rating ※1	10 W max.			1.1 W max.			
Current Consumption	-			50 mA max.			
Voltage Drop	3.5 V max.			22 mA @ 24 V DC max.			
Leakage Current	-			6 mA @ 24 V DC max.			
Indicator	Red LED			Green LED		Red LED	
Cable	Ø3.3 PVC - 24 AWG (0.22 mm ²) - 2 cores			Ø3.3 PVC - 24 AWG (0.22 mm ²) - 3 cores			
Operating Frequency	200 Hz			1000 Hz max.			
Magnet Requirement ※2	70 Gauss			60 Gauss		40 ~ 1000 Gauss	
Temperature Range	-			-10 ~ 70 °C			
Shock ※3	30 G			50 G			
Vibration ※4	-			9 G			
Enclosure Classification	-			IEC 60529 IP67			
Protection Circuit ※5	1			4		3, 4	

NOTE

- ※1 : WARNING : Never exceed rating (Watt = Voltage x Amperage). Permanent damage to sensor will occur.
- ※2 : Measuring standard target : Ø15.5 × Ø8 × 5t (Anisotropy rubber magnet)
- ※3 : Sin wave / X , Y , Z 3 directions / 3 times each direction / 11 ms each time.
- ※4 : Double amplitude 1.5 mm / 10 Hz ~ 55 Hz ~ 10 Hz (Sweep 1 min) / X , Y , Z 3 directions / 1 hour each time.
- ※5 : 1 = None / 2 = Short-circuit / 3 = Power Source Reverse polarity / 4 = Surge Suppression

Groove Dimensions

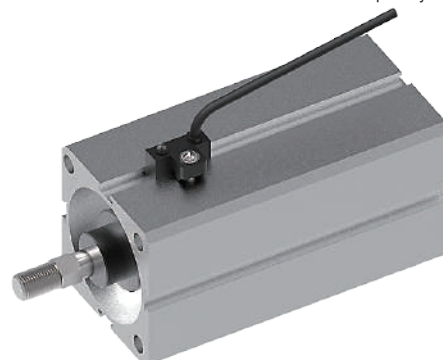
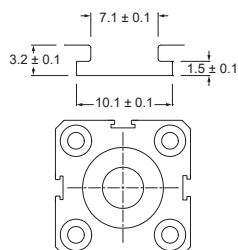

Unit : mm

KT-13 SERIES



Patented

Dimensions

KT-13R, KT-13DE, KT-13NE, KT-13PE /
KT-13R-QD, KT-13DE-QD, KT-13NE-QD, KT-13PE-QD

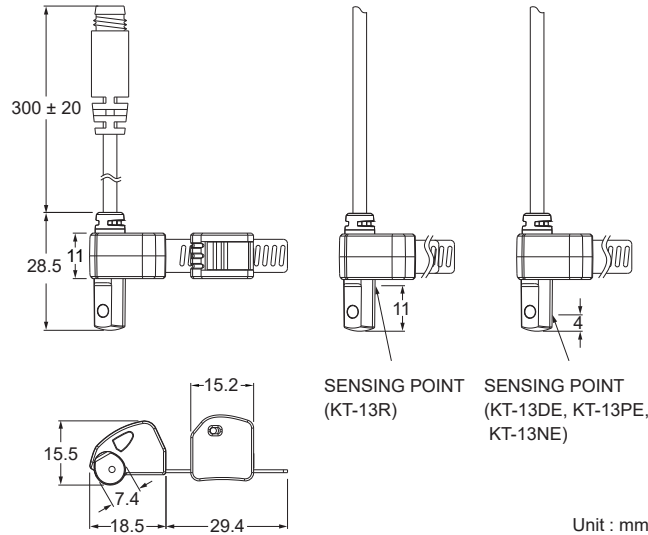

Unit : mm

QD Pinout

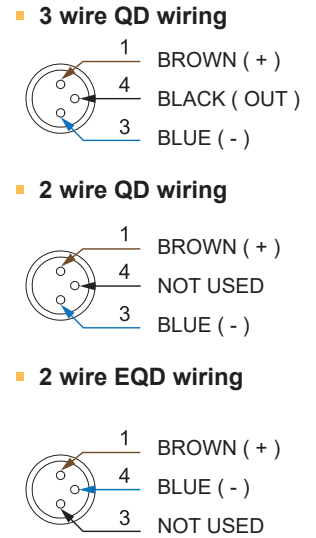

Specifications

MODEL	KT-13R	KT-13DE	KT-13NE	KT-13PE
Connect Diagram				
Characteristics	2-Wire Type		3-Wire Type	
Wiring Method	2-Wire Type		3-Wire Type	
Switching Logic	SPST, Normally Open		Solid State Output, Normally Open	
Sensor Type	Reed Switch	-	NPN Current Sinking	PNP Current Sourcing
Operating Voltage	5 ~ 240 V DC / AC		5 ~ 30 V DC	
Switching Current	100 mA max.	50 mA max.	200 mA max.	
Contact Rating ※1	10 W max.	1.5 W max.	6 W max.	
Current Consumption	-		6 mA @ 24 V DC max.	
Voltage Drop	3.5 V max.	3.7 V max.	0.5 V @ 200 mA max.	
Leakage Current	-	0.1 mA (40 uA) max.	0.01 mA max.	
Indicator	Red LED			Green LED
Cable	Ø3.3 PVC - 24 AWG (0.22 mm ²) - 2 cores		Ø3.3 PVC - 24 AWG (0.22 mm ²) - 3 cores	
Operating Frequency	200 Hz	1000 Hz max.		
Magnet Requirement ※2	55 Gauss	40 ~ 1000 Gauss		
Temperature Range	-10 ~ 70 °C			
Shock ※3	30 G	50 G		
Vibration ※4	9 G			
Enclosure Classification	IEC 60529 IP67			
Protection Circuit ※5	1	3, 4		

NOTE

※1 : WARNING : Never exceed rating (Watt = Voltage x Amperage).
Permanent damage to sensor will occur.

※2 : Measuring standard target : Ø15.5 × Ø8 × 5t (Anisotropy rubber magnet)

※3 : Sin wave / X , Y , Z 3 directions / 3 times each direction / 11 ms each time.

※4 : Double amplitude 1.5 mm / 10 Hz ~ 55 Hz ~ 10 Hz (Sweep 1 min) / X , Y , Z 3 directions / 1 hour each time.

※5 : 1 = None / 2 = Short-circuit / 3 = Power Source Reverse polarity / 4 = Surge Suppression

Clamps

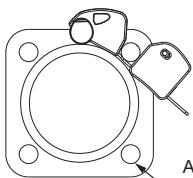

Applicable rod diameter Ø6 ~ Ø16
(Using ISO Tie-Rod cylinder range Ø32 ~ Ø200)



Hex key Size : 2 mm

Unit : mm

KT-15 SERIES



Dimensions

KT-15R, KT-15N, KT-15P /
KT-15R-QD, KT-15N-QD, KT-15P-QD

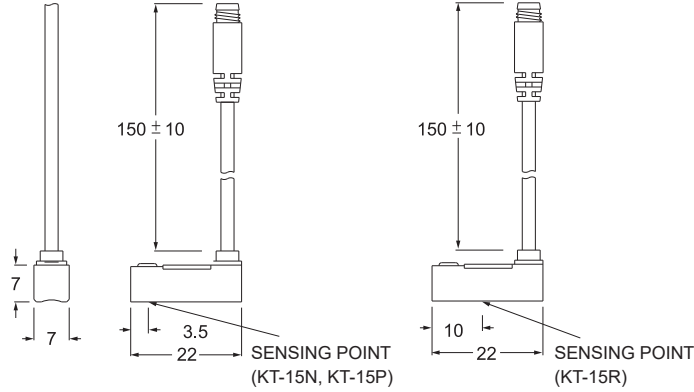

Unit : mm

QD Pinout

3 wire QD wiring

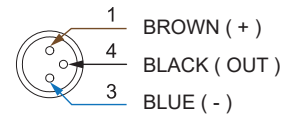

2 wire QD wiring

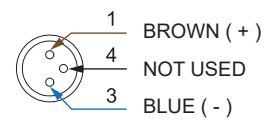

2 wire EQD wiring

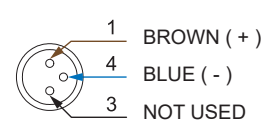

Specifications

MODEL	KT-15R	KT-15N	KT-15P
Connect Diagram			
Characteristics			
Wiring Method	2-Wire Type	3-Wire Type	
Switching Logic	SPST, Normally Open	Solid State Output, Normally Open	
Sensor Type	Reed Switch	NPN Current Sinking	PNP Current Sourcing
Operating Voltage	5 ~ 240 V DC / AC	5 ~ 30 V DC	
Switching Current	100 mA max.	200 mA max.	
Contact Rating ※1	10 W max.	6 W max.	
Current Consumption	-	20 mA @ 24 V DC max.	
Voltage Drop	3.5 V max.	0.5 V max.	
Leakage Current	-	0.01 mA max.	
Indicator	Red LED		Green LED
Cable	Ø2.8 PVC - 26 AWG (0.15 mm ²) - 2 cores	Ø2.8 PVC - 24 AWG (0.22 mm ²) - 3 cores	
Operating Frequency	200 Hz	1000 Hz	
Magnet Requirement ※2	50 Gauss	40 Gauss	
Temperature Range	-10 ~ 70°C		
Shock ※3	30 G	50 G	
Vibration ※4	9 G		
Enclosure Classification	IEC 60529 IP67		
Protection Circuit ※5	1	3, 4	

NOTE

※1 : WARNING : Never exceed rating (Watt = Voltage x Amperage).
Permanent damage to sensor will occur.

※2 : Measuring standard target : Ø15.5 × Ø8 × 5t (Anisotropy rubber magnet)

※3 : Sin wave / X , Y , Z 3 directions / 3 times each direction / 11 ms each time.

※4 : Double amplitude 1.5 mm / 10 Hz ~ 55 Hz ~ 10 Hz (Sweep 1 min) / X , Y , Z 3 directions / 1 hour each time.

※5 : 1 = None / 2 = Short-circuit / 3 = Power Source Reverse polarity / 4 = Surge Suppression

Clamps

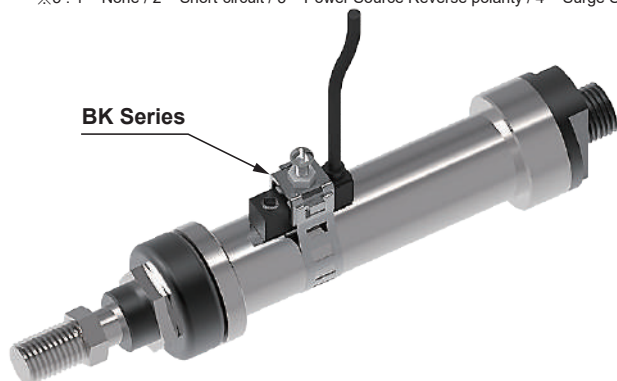
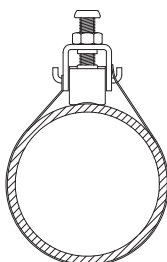

Dimensions

KT-16R, KT-16N, KT-16P /
KT-16R-QD, KT-16N-QD, KT-16P-QD

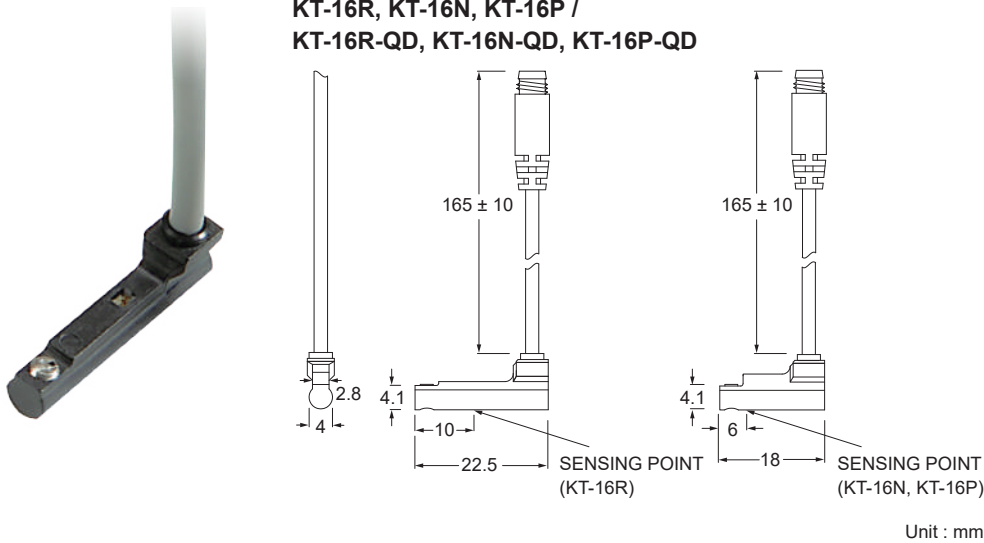

QD Pinout

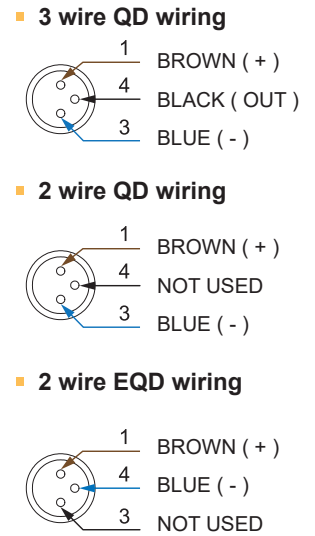

Specifications

MODEL	KT-16R	KT-16N	KT-16P
Connect Diagram			
Characteristics			
Wiring Method	2-Wire Type	3-Wire Type	
Switching Logic	SPST, Normally Open	Solid State Output, Normally Open	
Sensor Type	Reed Switch	NPN Current Sinking	PNP Current Sourcing
Operating Voltage	5 ~ 120 V DC / AC	5 ~ 30 V DC	
Switching Current	100 mA max.	50 mA max.	
Contact Rating ※1	6 W max.	1.5 W max.	
Current Consumption	-	7 mA @ 24 V DC max.	9 mA @ 24 V DC max.
Voltage Drop	3.5 V max.	1.5 V @ 50 mA max.	
Leakage Current	-	0.01 mA max.	
Indicator	Red LED		Green LED
Cable	Ø2.8 PUR - 26 AWG (0.15 mm ²) - 2 cores	Ø2.8 PUR - 26 AWG (0.15 mm ²) - 3 cores	
Operating Frequency	200 Hz	1000 Hz	
Magnet Requirement ※2	70 Gauss	40 Gauss	
Temperature Range	-10 ~ 70°C		
Shock ※3	30 G	50 G	
Vibration ※4	9 G		
Enclosure Classification	IEC 60529 IP67		
Protection Circuit ※5	1	3, 4	

NOTE

※1 : WARNING : Never exceed rating (Watt = Voltage x Amperage).
Permanent damage to sensor will occur.

※2 : Measuring standard target : Ø15.5 × Ø8 × 5t (Anisotropy rubber magnet)

※3 : Sin wave / X , Y , Z 3 directions / 3 times each direction / 11 ms each time.

※4 : Double amplitude 1.5 mm / 10 Hz ~ 55 Hz ~ 10 Hz (Sweep 1 min) / X , Y , Z 3 directions / 1 hour each time.

※5 : 1 = None / 2 = Short-circuit / 3 = Power Source Reverse polarity / 4 = Surge Suppression

Groove Dimensions

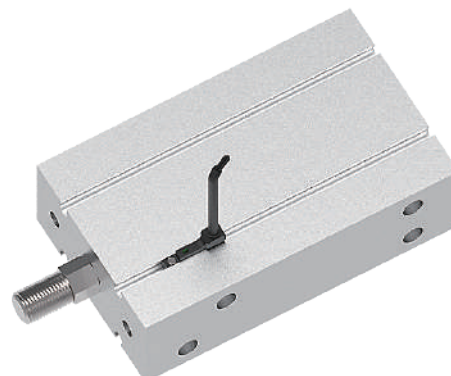
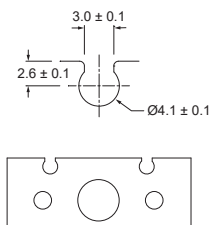

Unit : mm

KT-20 SERIES



Dimensions

KT-20R, KT-20DE, KT-20N, KT-20NE, KT-20P, KT-20PE /
KT-20R-QD, KT-20DE-QD, KT-20N-QD, KT-20NE-QD,
KT-20P-QD, KT-20PE-QD

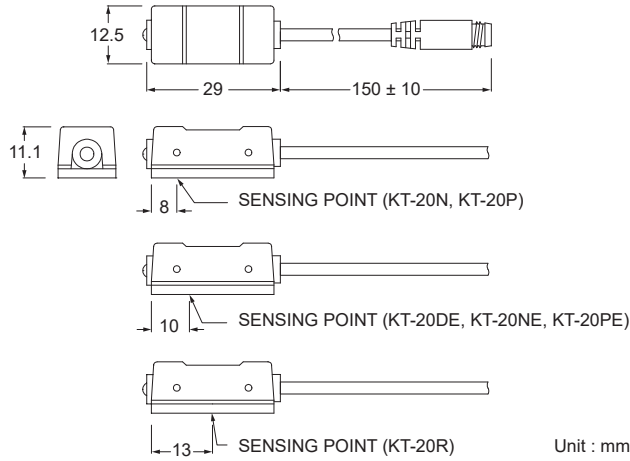

QD Pinout

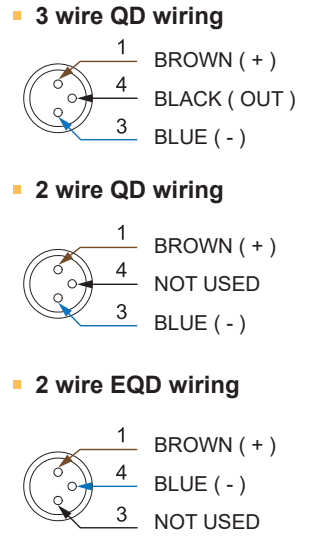

Specifications

MODEL	KT-20R	KT-20DE	KT-20N	KT-20NE	KT-20P	KT-20PE
Connect Diagram						
Characteristics						
Wiring Method	2-Wire type			3-Wire type		
Switching Logic	SPST, Normally Open		Solid State Output, Normally Open			
Sensor Type	Reed Switch	-	NPN Current Sinking		PNP Current Sourcing	
Operating Voltage	5 ~ 240 V DC / AC		5 ~ 30 V DC			
Switching Current	100 mA max.	50 mA max.	200 mA max.			
Contact Rating ※1	10 W max.	1.5 W max.	6 W max.			
Current Consumption	-		15 mA @ 24 V DC ※6	6 mA @ 24 V DC max.	15 mA @ 24 V DC ※6	6 mA @ 24 V DC max.
Voltage Drop	3.5 V max.	3.7 V max.	1.5 V max.	0.5 V max.	1.5 V max.	0.5 V max.
Leakage Current	-	0.1 mA (40 uA) max.	0.01 mA max.			
Indicator	Green LED		Red LED		Green LED	
Cable	Ø3.9 PVC - 24 AWG (0.22 mm ²) - 2 cores	Ø4 PVC - 24 AWG (0.22 mm ²) - 2 cores	Ø4 PVC - 24 AWG (0.22 mm ²) - 3 cores			
Operating Frequency	200 Hz		1000 Hz max.			
Magnet Requirement ※2	80 Gauss	50 ~ 1000 Gauss	70 Gauss	50 ~ 1000 Gauss	70 Gauss	50 ~ 1000 Gauss
Temperature Range	-10 ~ 70 °C					
Shock ※3	30 G		50 G			
Vibration ※4	9 G					
Enclosure Classification	IEC 60529 IP67					
Protection Circuit ※5	1	3, 4	2, 3, 4	3, 4	2, 3, 4	3, 4

NOTE

※1 : WARNING : Never exceed rating (Watt = Voltage x Amperage).
Permanent damage to sensor will occur.

※2 : Measuring standard target : Ø15.5 × Ø8 × 5t (Anisotropy rubber magnet)

※3 : Sin wave / X , Y , Z 3 directions / 3 times each direction / 11 ms each time.

※4 : Double amplitude 1.5 mm / 10 Hz ~ 55 Hz ~ 10 Hz (Sweep 1 min) / X , Y , Z 3 directions / 1 hour each time.

※5 : 1 = None / 2 = Short-circuit / 3 = Power Source Reverse polarity / 4 = Surge Suppression

※6 : TEST CONDITIONS : switch current at 200 mA

Clamps / Bracket

KT-20 & KT-21 series can be applied to many kind of cylinders

PH Series

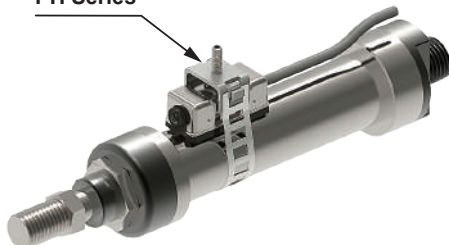

PI Series

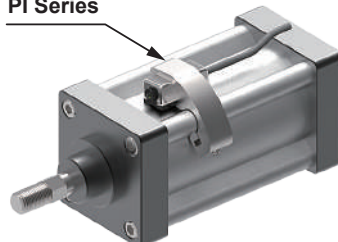

KT-21 SERIES



Dimensions

KT-21R, KT-21DE, KT-21N, KT-21NE, KT-21P, KT-21PE /
KT-21R-QD, KT-21DE-QD, KT-21N-QD, KT-21NE-QD,
KT-21P-QD, KT-21PE-QD

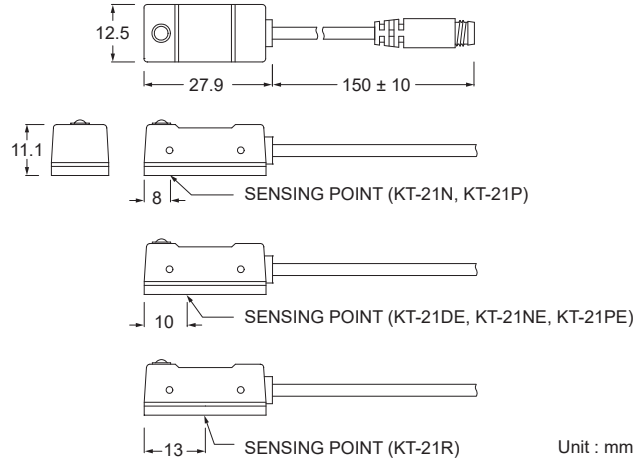

Unit : mm

QD Pinout

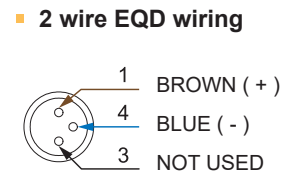
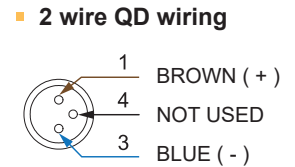
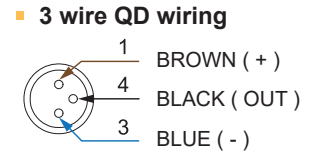

Specifications

MODEL	KT-21R	KT-21DE	KT-21N	KT-21NE	KT-21P	KT-21PE
Connect Diagram						
Characteristics						
Wiring Method	2-Wire type		3-Wire type			
Switching Logic	SPST, Normally Open		Solid State Output, Normally Open			
Sensor Type	Reed Switch	-	NPN Current Sinking		PNP Current Sourcing	
Operating Voltage	5 ~ 240 V DC / AC		5 ~ 30 V DC			
Switching Current	100 mA max.	50 mA max.	200 mA max.			
Contact Rating ※1	10 W max.	1.5 W max.	6 W max.			
Current Consumption	-		15 mA @ 24 V DC ※6	6 mA @ 24 V DC max.	15 mA @ 24 V DC ※6	6 mA @ 24 V DC max.
Voltage Drop	3.5 V max.	3.7 V max.	1.5 V max.	0.5 V max.	1.5 V max.	0.5 V max.
Leakage Current	-		0.01 mA max.			
Indicator	Green LED	Red LED		Green LED		
Cable	Ø3.9 PVC - 24 AWG (0.22 mm ²) - 2 cores	Ø4 PVC - 24 AWG (0.22 mm ²) - 2 cores	Ø4 PVC - 24 AWG (0.22 mm ²) - 3 cores			
Operating Frequency	200 Hz	1000 Hz max.				
Magnet Requirement ※2	80 Gauss	50 ~ 1000 Gauss	70 Gauss	50 ~ 1000 Gauss	70 Gauss	50 ~ 1000 Gauss
Temperature Range	-10 ~ 70 °C					
Shock ※3	30 G	50 G				
Vibration ※4	9 G					
Enclosure Classification	IEC 60529 IP67					
Protection Circuit ※5	1	3, 4	2, 3, 4	3, 4	2, 3, 4	3, 4

NOTE

※1 : WARNING : Never exceed rating (Watt = Voltage x Amperage).
Permanent damage to sensor will occur.

※2 : Measuring standard target : Ø15.5 × Ø8 × 5t (Anisotropy rubber magnet)

※3 : Sin wave / X , Y , Z 3 directions / 3 times each direction / 11 ms each time.

※4 : Double amplitude 1.5 mm / 10 Hz ~ 55 Hz ~ 10 Hz (Sweep 1 min) / X , Y , Z 3 directions / 1 hour each time.

※5 : 1 = None / 2 = Short-circuit / 3 = Power Source Reverse polarity / 4 = Surge Suppression

※6 : TEST CONDITIONS : switch current at 200 mA

Clamps / Bracket

KT-20 & KT-21 series can be applied to many kind of cylinders

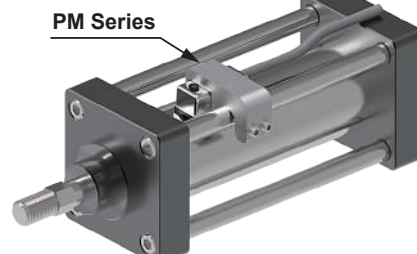
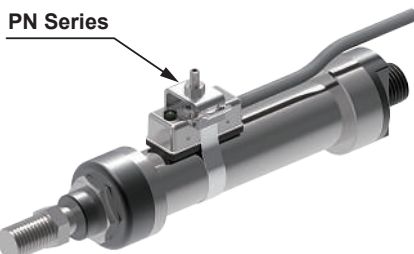

KT-31 SERIES



High Temp. Resistant
Max 140°C

Dimensions

M8 Connector
option is not available

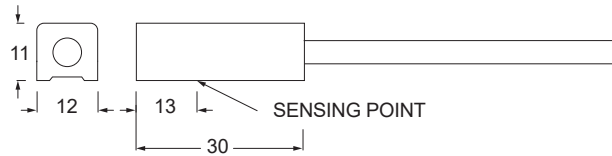

Unit : mm

Specifications

MODEL	KT-31R
Connect Diagram	
Characteristics	
Wiring Method	2-Wire Type
Switching Logic	SPST, Normally Open
Sensor Type	Reed Switch
Operating Voltage	5 ~ 240 V DC / AC
Switching Current	500 mA max.
Contact Rating ※1	10 W max.
Current Consumption	-
Voltage Drop	0.5 V max.
Leakage Current	-
Indicator	-
Cable	Ø3 Teflon - 24 AWG (0.22 mm ²) - 2 cores
Operating Frequency	200 Hz
Magnet Requirement ※2	40 Gauss
Temperature Range	-10 ~ 140°C
Shock ※3	30 G
Vibration ※4	9 G
Enclosure Classification	IEC 60529 IP67
Protection Circuit ※5	1

NOTE

※1 : WARNING : Never exceed rating (Watt = Voltage x Amperage).
Permanent damage to sensor will occur.

※2 : Measuring standard target : Ø15.5 × Ø8 × 5t (Anisotropy rubber magnet)

※3 : Sin wave / X , Y , Z 3 directions / 3 times each direction / 11 ms each time.

※4 : Double amplitude 1.5 mm / 10 Hz ~ 55 Hz ~ 10 Hz (Sweep 1 min) / X , Y , Z 3 directions / 1 hour each time.

※5 : 1 = None / 2 = Short-circuit / 3 = Power Source Reverse polarity / 4 = Surge Suppression

Bracket

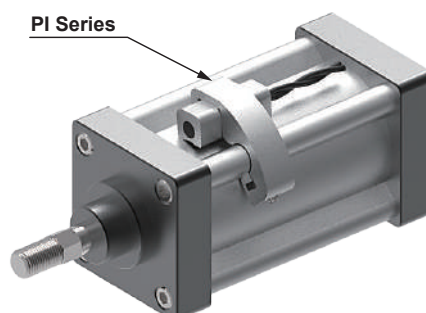

KT-32 SERIES



Dimensions

KT-32R, KT-32DE, KT-32N, KT-32NE, KT-32P,
KT-32PE, KT-32RP /
KT-32R-QD, KT-32DE-QD, KT-32N-QD, KT-32NE-QD,
KT-32P-QD, KT-32PE-QD, KT-32RP-QD

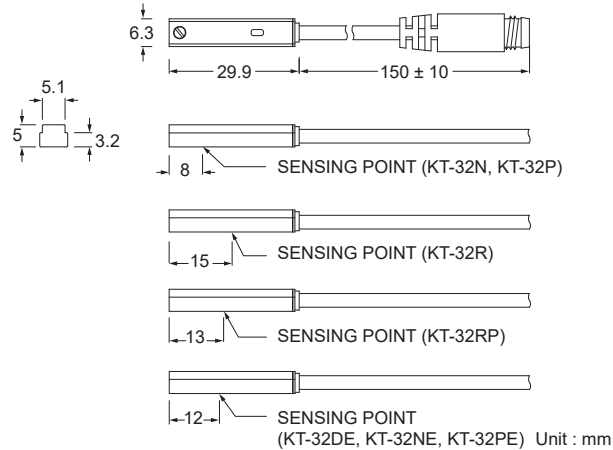

QD Pinout

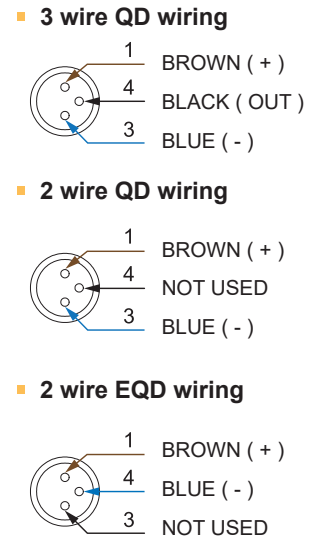

Specifications

MODEL	KT-32R	KT-32DE	KT-32N	KT-32NE	KT-32P	KT-32PE	KT-32RP
Connect Diagram							
Characteristics	2-Wire Type		3-Wire Type				
Wiring Method	2-Wire Type		3-Wire Type				
Switching Logic	SPST, Normally Open		Solid State Output, Normally Open				SPST, Normally Open
Sensor Type	Reed Switch	-	NPN Current Sinking		PNP Current Sourcing		Reed Switch
Operating Voltage	5 ~ 240 V DC / AC	5 ~ 30 V DC	10 ~ 30 V DC	5 ~ 30 V DC	10 ~ 30 V DC	5 ~ 30 V DC	10 ~ 30 V DC / AC
Switching Current	100 mA max.	50 mA max.	100 mA max.	200 mA max.	100 mA max.	200 mA max.	500 mA max.
Contact Rating ※1	10 W max.	1.5 W max.	3 W max.	6 W max.	3 W max.	6 W max.	10 W max.
Current Consumption			17 mA @ 24 V DC max.	6 mA @ 24 V DC max.	8 mA @ 24 V DC max.	6 mA @ 24 V DC max.	10 mA @ 24 V DC max.
Voltage Drop	3.5 V max.	3.7 V max.	1.5 V max.	0.5 V @ 200 mA max.	1.5 V max.	0.5 V @ 200 mA max.	0.1 V @ 100 mA max.
Leakage Current	-	0.1 mA (40 uA) max.	0.01 mA max.				-
Indicator	Red LED				Yellow LED	Green LED	Yellow LED
Cable	Ø3.3 PVC - 24 AWG (0.22 mm ²) - 2 cores		Ø3.2 PVC - 24 AWG (0.22 mm ²) - 3 cores				
Operating Frequency	200 Hz		1000 Hz				200 Hz
Magnet Requirement ※2	70 Gauss	40 ~ 1000 Gauss	60 Gauss	40 ~ 1000 Gauss	60 Gauss	40 ~ 1000 Gauss	60 Gauss
Temperature Range	-10 ~ 70 °C						
Shock ※3	30 G		50 G				30 G
Vibration ※4	9 G						
Enclosure Classification	IEC 60529 IP67						
Protection Circuit ※5	1	3, 4	2, 3, 4	3, 4	2, 3, 4	3, 4	1

NOTE

※1 : WARNING : Never exceed rating (Watt = Voltage x Amperage).
Permanent damage to sensor will occur.

※2 : Measuring standard target : Ø15.5 × Ø8 × 5t (Anisotropy rubber magnet)

※3 : Sin wave / X , Y , Z 3 directions / 3 times each direction / 11 ms each time.

※4 : Double amplitude 1.5 mm / 10 Hz ~ 55 Hz ~ 10 Hz (Sweep 1 min) / X , Y , Z 3 directions / 1 hour each time.

※5 : 1 = None / 2 = Short-circuit / 3 = Power Source Reverse polarity / 4 = Surge Suppression

Groove Dimensions

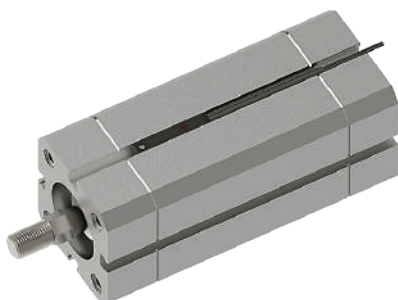
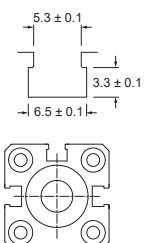

Bracket

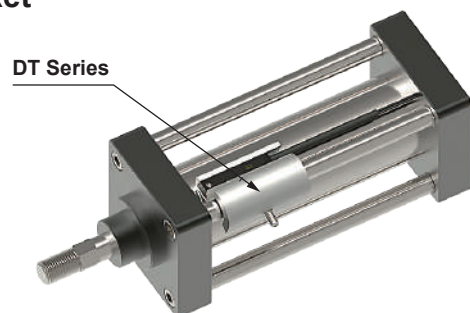

Unit : mm

KT-32-EX SERIES



Explosion Proof

Dimensions

KT-32R-EX, KT-32N-EX, KT-32P-EX, KT-32RP-EX

M8 Connector option is not available

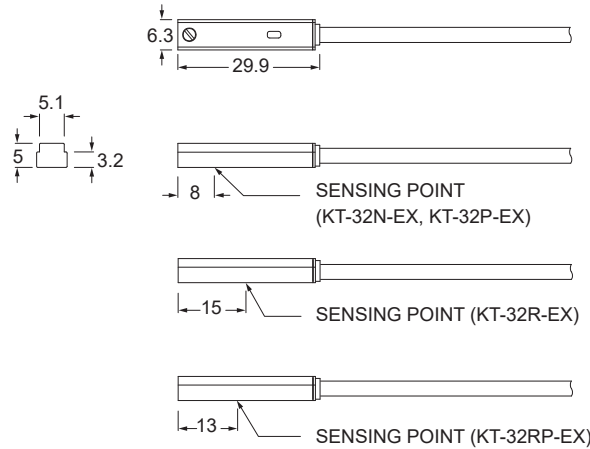

Unit : mm

Specifications

MODEL	KT-32R-EX	KT-32N-EX	KT-32P-EX	KT-32RP-EX
Connect Diagram				
Characteristics				
Wiring Method	2-Wire Type	3-Wire Type		
Switching Logic	SPST, Normally Open	Solid State Output, Normally Open		SPST, Normally Open
Sensor Type	Reed Switch	NPN Current Sinking	PNP Current Sourcing	Reed Switch
Operating Voltage	5 ~ 30 V DC / AC	10 ~ 30 V DC		10 ~ 30 V DC / AC
Switching Current		100 mA max.		500 mA max.
Contact Rating ※1	10 W max.	3 W max.		10 W max.
Current Consumption	-	17 mA @ 24 V DC max.	8 mA @ 24 V DC max.	10 mA @ 24 V DC max.
Voltage Drop	3.5 V max.	1.5 V max.		0.1 V @ 100 mA max.
Leakage Current	-	0.01 mA max.		-
Indicator	Red LED		Yellow LED	
Cable	Ø3.3 PVC - 24 AWG (0.22 mm ²) - 2 cores		Ø3.2 PVC - 24 AWG (0.22 mm ²) - 3 cores	
Operating Frequency	200 Hz	1000 Hz		200 Hz
Magnet Requirement ※2	70 Gauss	60 Gauss		
Temperature Range	-10 ~ 70 °C			
Shock ※3	30 G	50 G		30 G
Vibration ※4	9 G			
Enclosure Classification	IEC 60529 IP67			
Protection Circuit ※5	1	2, 3, 4		1
CE ATEX APPROVAL Baseefa14ATEX0118	II 3GD Ex ic IIB T4 Gc (-10 °C ≤ Ta ≤ +70 °C) Ex ic IIIC T135°C Dc (-10 °C ≤ Ta ≤ +70 °C)			

NOTE

※1 : WARNING : Never exceed rating (Watt = Voltage x Amperage).
Permanent damage to sensor will occur.

※2 : Measuring standard target : Ø15.5 × Ø8 × 5t (Anisotropy rubber magnet)

※3 : Sin wave / X , Y , Z 3 directions / 3 times each direction / 11 ms each time.

※4 : Double amplitude 1.5 mm / 10 Hz ~ 55 Hz ~ 10 Hz (Sweep 1 min) / X , Y , Z 3 directions / 1 hour each time.

※5 : 1 = None / 2 = Short-circuit / 3 = Power Source Reverse polarity / 4 = Surge Suppression

Groove Dimensions

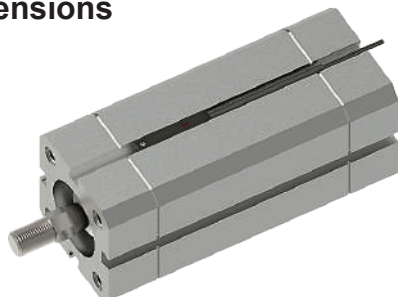
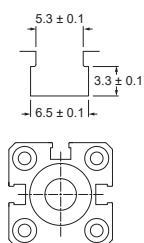

Bracket

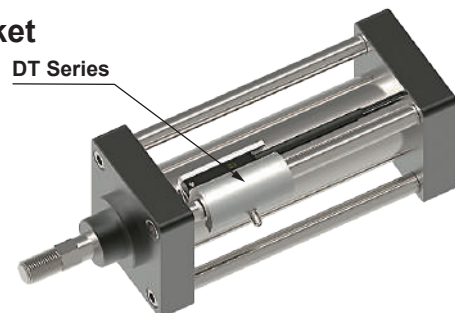

Unit : mm

KT-33 SERIES



Dimensions



KT-33R, KT-33D, KT-33N, KT-33P /
KT-33R-QD, KT-33D-QD, KT-33N-QD, KT-33P-QD

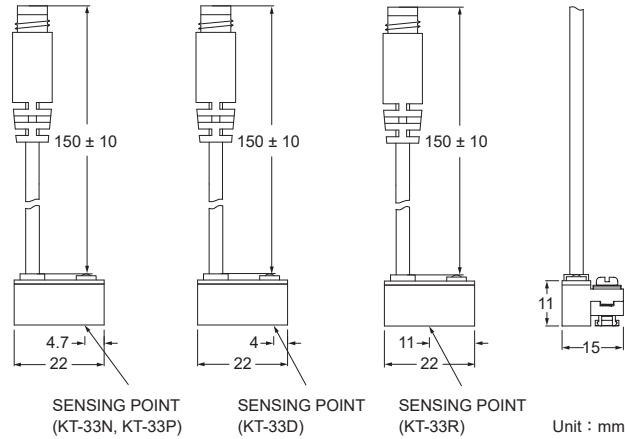

QD Pinout

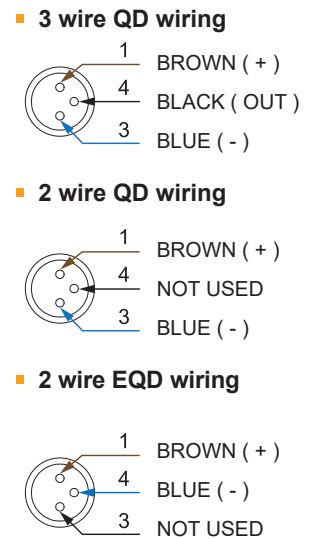

Specifications

MODEL	KT-33R	KT-33D	KT-33N	KT-33P
Connect Diagram				
Characteristics				
Wiring Method	2-Wire Type		3-Wire Type	
Switching Logic	SPST, Normally Open		Solid State Output, Normally Open	
Sensor Type	Reed Switch	-	NPN Current Sinking	PNP Current Sourcing
Operating Voltage	5 ~ 240 V DC / AC	10 ~ 28 V DC	5 ~ 30 V DC	
Switching Current	100 mA max.	4 ~ 40 mA max.	200 mA max.	
Contact Rating ※1	10 W max.	1.5 W max.	6 W max.	
Current Consumption	-		22 mA @ 24 V DC max.	20 mA @ 24 V DC max.
Voltage Drop	3.5 V max.		0.5 V max.	
Leakage Current	-	1 mA max.	0.01 mA max.	
Indicator	Red LED	Green LED	Red LED	Green LED
Cable	Ø3.3 PVC - 24 AWG (0.22 mm ²) - 2 cores		Ø3.2 PVC - 24 AWG (0.22 mm ²) - 3 cores	
Operating Frequency	200 Hz		1000 Hz	
Magnet Requirement ※2	80 Gauss		70 Gauss	
Temperature Range	-10 ~ 70 °C			
Shock ※3	30 G		50 G	
Vibration ※4	9 G			
Enclosure Classification	IEC 60529 IP67			
Protection Circuit ※5	1	4	3, 4	

NOTE

※1 : WARNING : Never exceed rating (Watt = Voltage x Amperage).
Permanent damage to sensor will occur.

※2 : Measuring standard target : Ø15.5 × Ø8 × 5t (Anisotropy rubber magnet)

※3 : Sin wave / X, Y, Z 3 directions / 3 times each direction / 11 ms each time.

※4 : Double amplitude 1.5 mm / 10 Hz ~ 55 Hz ~ 10 Hz (Sweep 1 min) / X, Y, Z 3 directions / 1 hour each time.

※5 : 1 = None / 2 = Short-circuit / 3 = Power Source Reverse polarity / 4 = Surge Suppression

Groove Dimensions

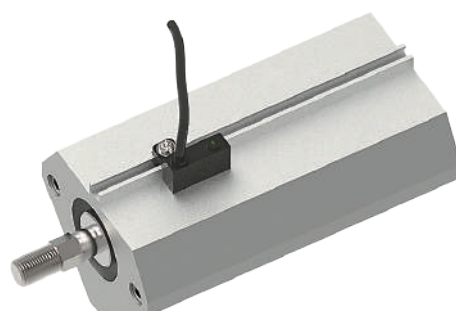
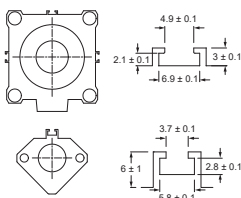

Unit : mm

KT-36 SERIES



Compact Size



Dimensions

KT-36D, KT-36DE, KT-36N, KT-36NE, KT-36P, KT-36PE /
KT-36D-QD, KT-36DE-QD, KT-36N-QD, KT-36NE-QD,
KT-36P-QD, KT-36PE-QD

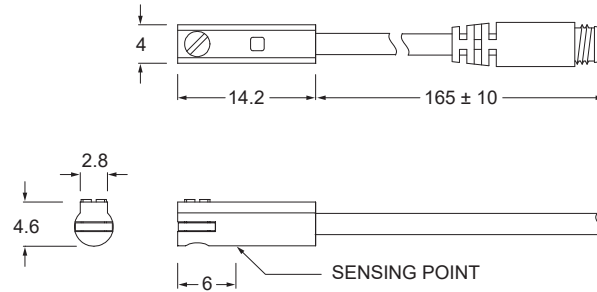

Unit : mm

QD Pinout

3 wire QD wiring

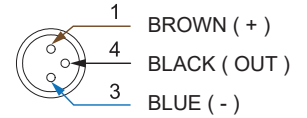

2 wire QD wiring

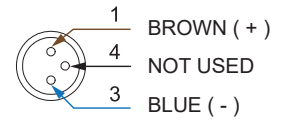

2 wire EQD wiring

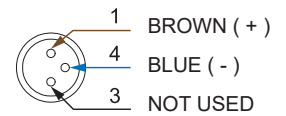

Specifications

MODEL	KT-36D	KT-36DE	KT-36N	KT-36NE	KT-36P	KT-36PE
Connect Diagram						
Characteristics						
Wiring Method	2-Wire type		3-Wire type			
Switching Logic	Solid State Output, Normally Open					
Sensor Type	-		NPN Current Sinking		PNP Current Sourcing	
Operating Voltage	10 ~ 28 V DC	5 ~ 30 V DC	4.5 ~ 28 V DC	5 ~ 30 V DC	4.5 ~ 28 V DC	5 ~ 30 V DC
Switching Current	4 ~ 20 mA max.		50 mA max.			
Contact Rating ※1	0.6 W max.		1.5 W max.			
Current Consumption	-		10 mA @ 24 V DC max.			
Voltage Drop	3.5 V max.		0.5 V @ 50 mA max.			
Leakage Current	0.8 mA max.	0.1 mA (40 uA) max.	0.01 mA max.			
Indicator	Red LED					
Cable	Ø2.6 PVC - 26 AWG (0.15 mm ²) - 2 cores		Ø2.6 PVC - 26 AWG (0.15 mm ²) - 3 cores			
Operating Frequency	1000 Hz max.					
Magnet Requirement ※2	40 Gauss	40 ~ 1000 Gauss	40 Gauss	40 ~ 1000 Gauss	40 Gauss	40 ~ 1000 Gauss
Temperature Range	-10 ~ 70°C					
Shock ※3	50 G					
Vibration ※4	9 G					
Enclosure Classification	IEC 60529 IP67					
Protection Circuit ※5	4		3, 4			

NOTE

※1 : WARNING : Never exceed rating (Watt = Voltage x Amperage).
Permanent damage to sensor will occur.

※2 : Measuring standard target : Ø15.5 × Ø8 × 5t (Anisotropy rubber magnet)

※3 : Sin wave / X , Y , Z 3 directions / 3 times each direction / 11 ms each time.

※4 : Double amplitude 1.5 mm / 10 Hz ~ 55 Hz ~ 10 Hz (Sweep 1 min) / X , Y , Z 3 directions / 1 hour each time.

※5 : 1 = None / 2 = Short-circuit / 3 = Power Source Reverse polarity / 4 = Surge Suppression

Groove Dimensions

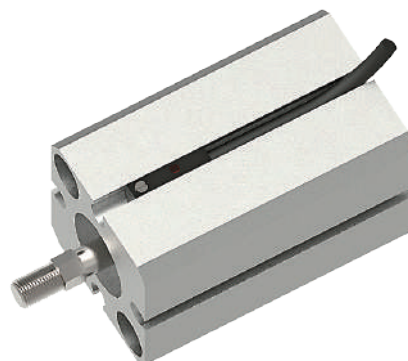
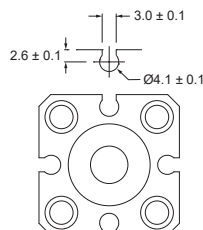

Unit : mm

KT-37 SERIES



Compact Size



Dimensions

KT-37D, KT-37DE, KT-37N, KT-37NE, KT-37P, KT-37PE /
KT-37D-QD, KT-37DE-QD, KT-37N-QD, KT-37NE-QD,
KT-37P-QD, KT-37PE-QD

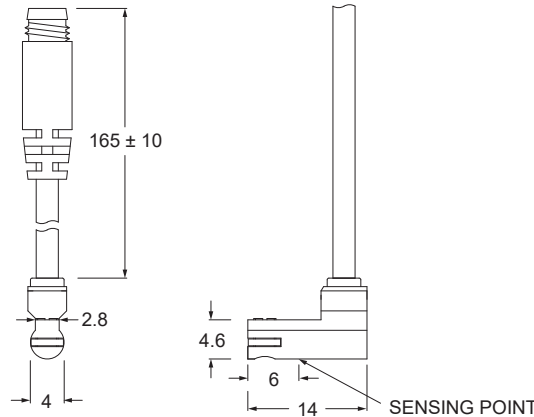

Unit : mm

QD Pinout

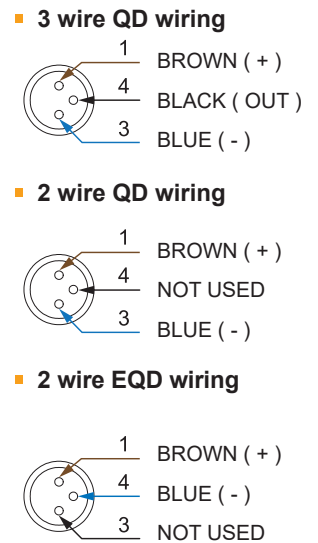

Specifications

MODEL	KT-37D	KT-37DE	KT-37N	KT-37NE	KT-37P	KT-37PE
Connect Diagram						
Characteristics						
Wiring Method	2-Wire type		3-Wire type			
Switching Logic	Solid State Output, Normally Open					
Sensor Type	-		NPN Current Sinking		PNP Current Sourcing	
Operating Voltage	10 ~ 28 V DC	5 ~ 30 V DC	4.5 ~ 28 V DC	5 ~ 30 V DC	4.5 ~ 28 V DC	5 ~ 30 V DC
Switching Current	4 ~ 20 mA max.		50 mA max.			
Contact Rating ※1	0.6 W max.		1.5 W max.			
Current Consumption	-		10 mA @ 24 V DC max.			
Voltage Drop	3.5 V max.		0.5 V @ 50 mA max.			
Leakage Current	0.8 mA max.	0.1 mA (40 uA) max.	0.01 mA max.			
Indicator	Red LED					
Cable	Ø2.6 PVC - 26 AWG (0.15 mm ²) - 2 cores		Ø2.6 PVC - 26 AWG (0.15 mm ²) - 3 cores			
Operating Frequency	1000 Hz max.					
Magnet Requirement ※2	40 Gauss	40 ~ 1000 Gauss	40 Gauss	40 ~ 1000 Gauss	40 Gauss	40 ~ 1000 Gauss
Temperature Range	-10 ~ 70°C					
Shock ※3	50 G					
Vibration ※4	9 G					
Enclosure Classification	IEC 60529 IP67					
Protection Circuit ※5	4		3, 4			

NOTE

※1 : WARNING : Never exceed rating (Watt = Voltage x Amperage).
Permanent damage to sensor will occur.

※2 : Measuring standard target : Ø15.5 × Ø8 × 5t (Anisotropy rubber magnet)

※3 : Sin wave / X , Y , Z 3 directions / 3 times each direction / 11 ms each time.

※4 : Double amplitude 1.5 mm / 10 Hz ~ 55 Hz ~ 10 Hz (Sweep 1 min) / X , Y , Z 3 directions / 1 hour each time.

※5 : 1 = None / 2 = Short-circuit / 3 = Power Source Reverse polarity / 4 = Surge Suppression

Groove Dimensions

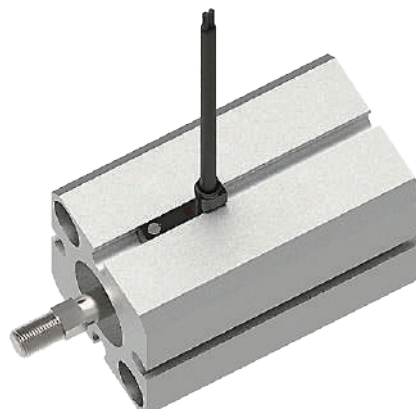
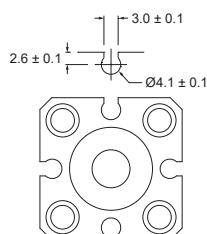

Unit : mm

KT-38 SERIES



Compact Size



Dimensions

KT-38D, KT-38N, KT-38P /
KT-38D-QD, KT-38N-QD, KT-38P-QD

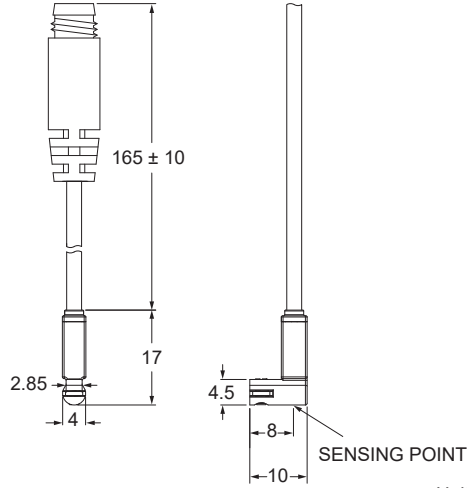

Unit : mm

QD Pinout

- 3 wire QD wiring
 - 1 BROWN (+)
 - 4 BLACK (OUT)
 - 3 BLUE (-)
- 2 wire QD wiring
 - 1 BROWN (+)
 - 4 NOT USED
 - 3 BLUE (-)
- 2 wire EQD wiring
 - 1 BROWN (+)
 - 4 BLUE (-)
 - 3 NOT USED

Specifications

MODEL	KT-38D	KT-38N	KT-38P
Connect Diagram			
Characteristics			
Wiring Method	2-Wire Type	3-Wire Type	
Switching Logic	Solid State Output, Normally Open		
Sensor Type	-	NPN Current Sinking	PNP Current Sourcing
Operating Voltage	10 ~ 28 V DC	5 ~ 28 V DC	
Switching Current	4 ~ 20 mA max.	50 mA max.	
Contact Rating ※1	0.6 W max.	1.5 W max.	
Current Consumption	-	10 mA @ 24 V DC max.	
Voltage Drop	3.5 V max.	0.5 V @ 50 mA max.	
Leakage Current	0.8 mA max.	0.01 mA max.	
Indicator	Red LED		
Cable	Ø2.6 PVC - 26AWG (0.15 mm ²) - 2 cores	Ø2.6 PVC - 26AWG (0.15 mm ²) - 3 cores	
Operating Frequency	1000 Hz		
Magnet Requirement ※2	40 Gauss		
Temperature Range	-10 ~ 70 °C		
Shock ※3	50 G		
Vibration ※4	9 G		
Enclosure Classification	IEC 60529 IP67		
Protection Circuit ※5	4	3, 4	

NOTE

※1 : WARNING : Never exceed rating (Watt = Voltage x Amperage).
Permanent damage to sensor will occur.

※2 : Measuring standard target : Ø15.5 × Ø8 × 5t (Anisotropy rubber magnet)

※3 : Sin wave / X , Y , Z 3 directions / 3 times each direction / 11 ms each time.

※4 : Double amplitude 1.5 mm / 10 Hz ~ 55 Hz ~ 10 Hz (Sweep 1 min) / X , Y , Z 3 directions / 1 hour each time.

※5 : 1 = None / 2 = Short-circuit / 3 = Power Source Reverse polarity / 4 = Surge Suppression

Groove Dimensions

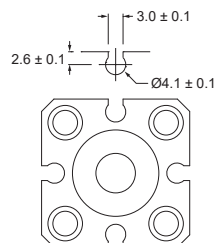

Unit : mm

KT-39 SERIES



Compact Size



Dimensions

KT-39DE, KT-39NE, KT-39PE /
KT-39DE-QD, KT-39NE-QD, KT-39PE-QD

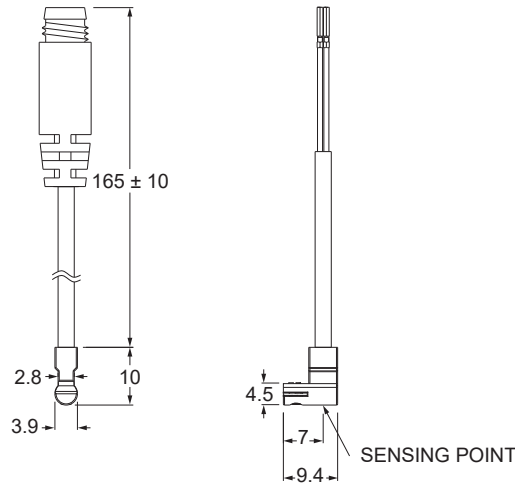

Unit : mm

QD Pinout

3 wire QD wiring

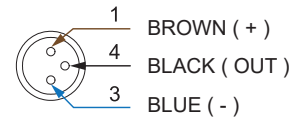

2 wire QD wiring

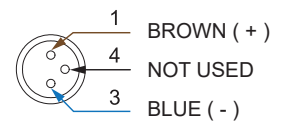

2 wire EQD wiring

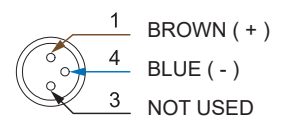

Specifications

MODEL	KT-39DE	KT-39NE	KT-39PE
Connect Diagram			
Characteristics			
Wiring Method	2-Wire type	3-Wire type	
Switching Logic	Solid State Output, Normally Open		
Sensor Type	-	NPN Current Sinking	PNP Current Sourcing
Operating Voltage	5 ~ 30 V DC		
Switching Current	50 mA max.	80 mA max.	
Contact Rating ※1	1.5 W max.	2.2 W max.	
Current Consumption	-	6 mA @ 24 V DC max.	
Voltage Drop	3.5 V max.	0.5 V @ 50 mA max.	
Leakage Current	0.1 mA (40 uA) max.	0.01 mA max.	
Indicator	Red LED		
Cable	Ø2.6 PVC - 26 AWG (0.15 mm ²) - 2 cores	Ø2.6 PVC - 26 AWG (0.15 mm ²) - 3 cores	
Operating Frequency	1000 Hz		
Magnet Requirement ※2	40 ~ 1000 Gauss		
Temperature Range	-10 ~ 70 °C		
Shock ※3	50 G		
Vibration ※4	9 G		
Enclosure Classification	IEC 60529 IP67		
Protection Circuit ※5	3, 4		

NOTE

※1 : WARNING : Never exceed rating (Watt = Voltage x Amperage).
Permanent damage to sensor will occur.

※2 : Measuring standard target : Ø15.5 × Ø8 × 5t (Anisotropy rubber magnet)

※3 : Sin wave / X , Y , Z 3 directions / 3 times each direction / 11 ms each time.

※4 : Double amplitude 1.5 mm / 10 Hz ~ 55 Hz ~ 10 Hz (Sweep 1 min) / X , Y , Z 3 directions / 1 hour each time.

※5 : 1 = None / 2 = Short-circuit / 3 = Power Source Reverse polarity / 4 = Surge Suppression

Groove Dimensions

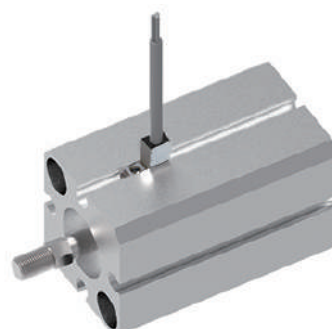
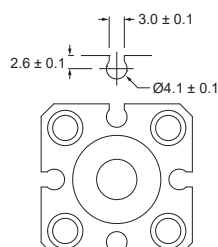

Unit : mm

KT-40 SERIES



Dimensions

KT-40R, KT-40N, KT-40P, KT-40RP /
KT-40R-QD, KT-40N-QD, KT-40P-QD, KT-40RP-QD

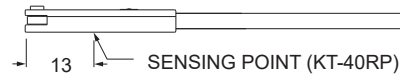
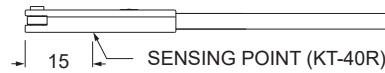
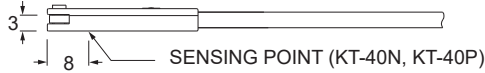
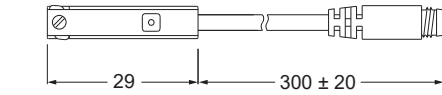
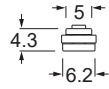

QD Pinout

3 wire QD wiring

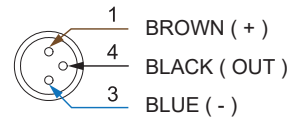

2 wire QD wiring

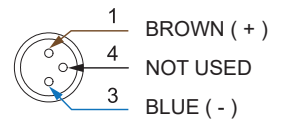

2 wire EQD wiring

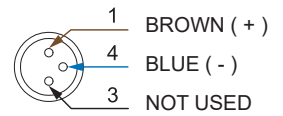

Unit : mm

Specifications

MODEL	KT-40R	KT-40N	KT-40P	KT-40RP
Connect Diagram				
Characteristics				
Wiring Method	2-Wire Type	3-Wire Type		
Switching Logic	SPST, Normally Open	Solid State Output, Normally Open		SPST, Normally Open
Sensor Type	Reed Switch	NPN Current Sinking	PNP Current Sourcing	Reed Switch
Operating Voltage	5 ~ 120 V DC / AC	10 ~ 30 V DC		10 ~ 30 V DC / AC
Switching Current		100 mA max.		500 mA max.
Contact Rating ※1	10 W max.	3 W max.		10 W max.
Current Consumption	-	8 mA @ 24 V DC max.		10 mA @ 24 V DC max.
Voltage Drop	3.5 V max.	1.5 V max.		0.1 V @ 100 mA max.
Leakage Current	-	0.01 mA max.		-
Indicator	Red LED		Yellow LED	
Cable	Ø3 PUR - 26 AWG (0.15 mm ²) - 2 cores		Ø3 PUR - 26 AWG (0.15 mm ²) - 3 cores	
Operating Frequency	200 Hz	1000 Hz		200 Hz
Magnet Requirement ※2	50 Gauss	45 Gauss		
Temperature Range	-10 ~ 70 °C			
Shock ※3	30 G	50 G		30 G
Vibration ※4	9 G			
Enclosure Classification	IEC 60529 IP67			
Protection Circuit ※5	1	2, 3, 4		1

NOTE

※1 : WARNING : Never exceed rating (Watt = Voltage x Amperage).

Permanent damage to sensor will occur.

※2 : Measuring standard target : Ø15.5 × Ø8 × 5t (Anisotropy rubber magnet)

※3 : Sin wave / X , Y , Z 3 directions / 3 times each direction / 11 ms each time.

※4 : Double amplitude 1.5 mm / 10 Hz ~ 55 Hz ~ 10 Hz (Sweep 1 min) / X , Y , Z 3 directions / 1 hour each time.

※5 : 1 = None / 2 = Short-circuit / 3 = Power Source Reverse polarity / 4 = Surge Suppression

Groove Dimensions

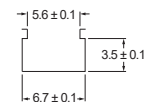

Clamp / Bracket

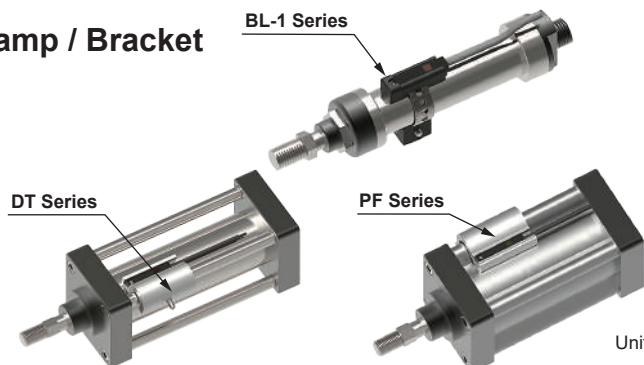

Unit : mm

KT-47 SERIES



Dimensions

KT-47R, KT-47N, KT-47P /
KT-47R-QD, KT-47N-QD, KT-47P-QD

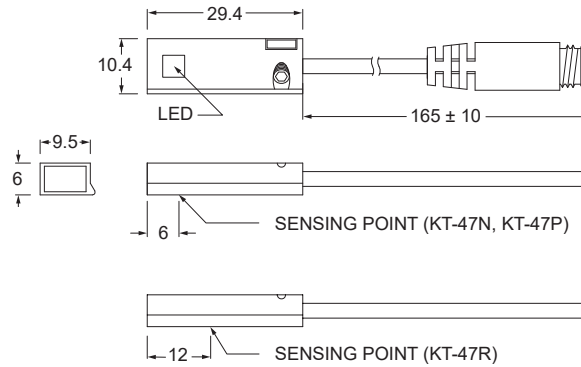

Unit : mm

QD Pinout

3 wire QD wiring

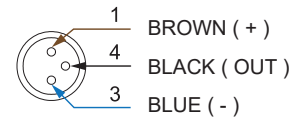

2 wire QD wiring

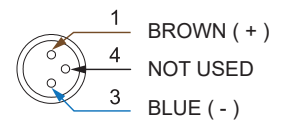

2 wire EQD wiring

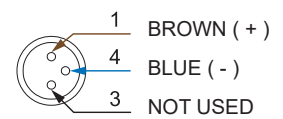

Specifications

MODEL	KT-47R	KT-47N	KT-47P
Connect Diagram			
Characteristics			
Wiring Method	2-Wire Type	3-Wire Type	
Switching Logic	SPST, Normally Open	Solid State Output, Normally Open	
Sensor Type	Reed Switch	NPN Current Sinking	PNP Current Sourcing
Operating Voltage	5 ~ 240 V DC / AC	5 ~ 30 V DC	
Switching Current	500 mA max.	200 mA max.	
Contact Rating ※1	10 W max.	6 W max.	
Current Consumption	-	22 mA @ 24 V DC max.	20 mA @ 24 V DC max.
Voltage Drop	3.0 V max.	2.0 V max.	2.5 V max.
Leakage Current	-	0.01 mA max.	
Indicator		Yellow LED	
Cable	Ø2.8 PVC - 26AWG (0.15 mm ²) - 2 cores	Ø2.8 PUR - 26AWG (0.15 mm ²) - 3 cores	
Operating Frequency	200 Hz	1000 Hz	
Magnet Requirement ※2		50 Gauss	
Temperature Range		-10 ~ 70°C	
Shock ※3	30 G	50 G	
Vibration ※4		9 G	
Enclosure Classification		IEC 60529 IP67	
Protection Circuit ※5	1	2, 3, 4	

NOTE

※1 : WARNING : Never exceed rating (Watt = Voltage x Amperage).
Permanent damage to sensor will occur.

※2 : Measuring standard target : Ø15.5 × Ø8 × 5t (Anisotropy rubber magnet)

※3 : Sin wave / X , Y , Z 3 directions / 3 times each direction / 11 ms each time.

※4 : Double amplitude 1.5 mm / 10 Hz ~ 55 Hz ~ 10 Hz (Sweep 1 min) / X , Y , Z 3 directions / 1 hour each time.

※5 : 1 = None / 2 = Short-circuit / 3 = Power Source Reverse polarity / 4 = Surge Suppression

Groove Dimensions

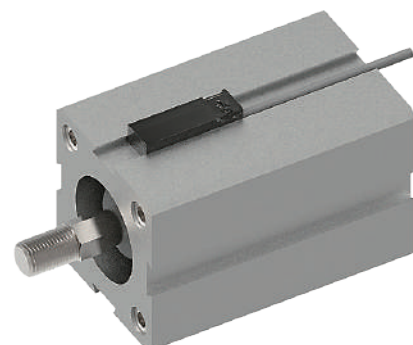
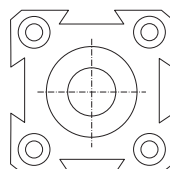
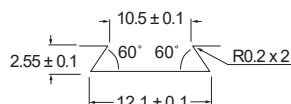

Unit : mm

KT-48 SERIES



Dimensions

KT-48R, KT-48DE, KT-48N, KT-48NE, KT-48P, KT-48PE /
KT-48R-QD, KT-48DE-QD, KT-48N-QD, KT-48NE-QD,
KT-48P-QD, KT-48PE-QD

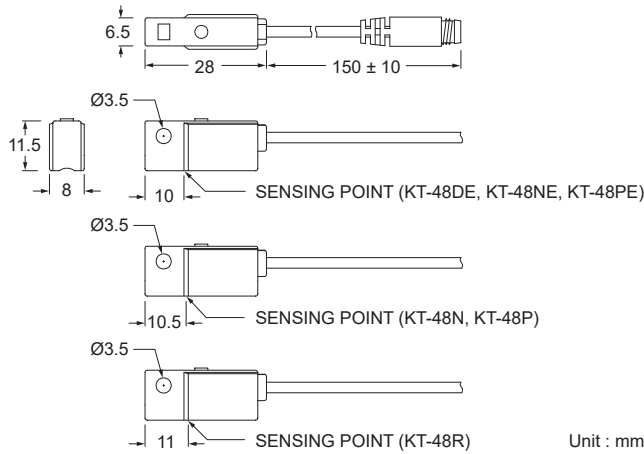

Unit : mm

QD Pinout

3 wire QD wiring

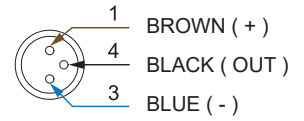

2 wire QD wiring

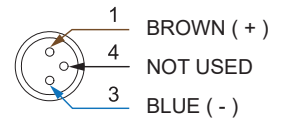

2 wire EQD wiring

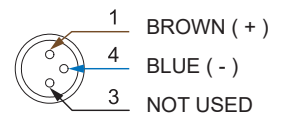

Specifications

MODEL	KT-48R	KT-48DE	KT-48N	KT-48NE	KT-48P	KT-48PE
Connect Diagram						
Characteristics	2-Wire type		3-Wire type			
Wiring Method	2-Wire type		3-Wire type			
Switching Logic	SPST, Normally Open		Solid State Output, Normally Open			
Sensor Type	Reed Switch	-	NPN Current Sinking		PNP Current Sourcing	
Operating Voltage	5 ~ 240 V DC / AC	5 ~ 30 V DC	5 ~ 28 V DC	5 ~ 30 V DC	5 ~ 28 V DC	5 ~ 30 V DC
Switching Current	100 mA max.	50 mA max.	10 mA @ 24 V DC max.	6 mA @ 24 V DC max.	50 mA max.	200 mA max.
Contact Rating ※1	10 W max.	1.5 W max.	6 W max.	1.5 W max.	6 W max.	6 W max.
Current Consumption	-	-	10 mA @ 24 V DC max.	6 mA @ 24 V DC max.	10 mA @ 24 V DC max.	6 mA @ 24 V DC max.
Voltage Drop	3.5 V max.	3.7 V max.	1.5 V @ 50 mA max.	0.5 V @ 200 mA max.	1.5 V @ 50 mA max.	0.5 V @ 200 mA max.
Leakage Current	-	0.1 mA (40 uA) max.	0.01 mA max.			
Indicator	Red LED			Green LED		
Cable	Ø3.3 PVC - 24 AWG (0.22 mm ²) - 2 cores		Ø3.3 PVC - 24 AWG (0.22 mm ²) - 3 cores			
Operating Frequency	200 Hz		1000 Hz max.			
Magnet Requirement ※2	110 Gauss	40 ~ 1000 Gauss	75 Gauss	40 ~ 1000 Gauss	75 Gauss	40 ~ 1000 Gauss
Temperature Range	-10 ~ 70 °C					
Shock ※3	30 G		50 G			
Vibration ※4	9 G					
Enclosure Classification	IEC 60529 IP67					
Protection Circuit ※5	1		3, 4			

NOTE

※1 : WARNING : Never exceed rating (Watt = Voltage x Amperage).
Permanent damage to sensor will occur.

※2 : Measuring standard target : Ø15.5 × Ø8 × 5t (Anisotropy rubber magnet)

※3 : Sin wave / X , Y , Z 3 directions / 3 times each direction / 11 ms each time.

※4 : Double amplitude 1.5 mm / 10 Hz ~ 55 Hz ~ 10 Hz (Sweep 1 min) / X , Y , Z 3 directions / 1 hour each time.

※5 : 1 = None / 2 = Short-circuit / 3 = Power Source Reverse polarity / 4 = Surge Suppression

Clamp

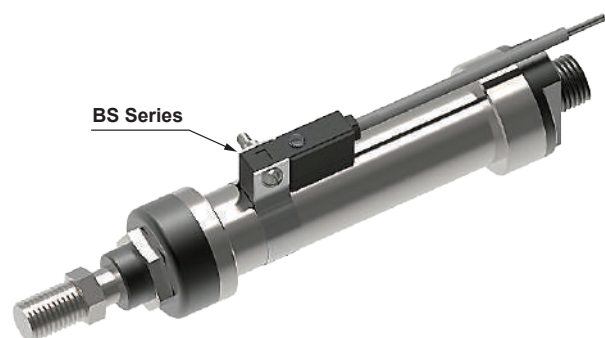
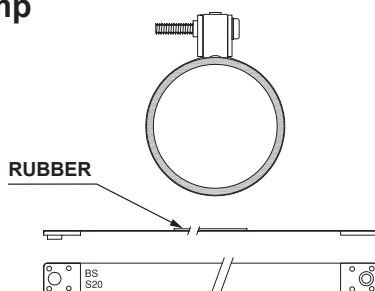

KT-50 SERIES



Dimensions

KT-50R, KT-50D, KT-50N, KT-50P, KT-50RP, /
KT-50R-QD, KT-50D-QD, KT-50N-QD, KT-50P-QD,
KT-50RP-QD

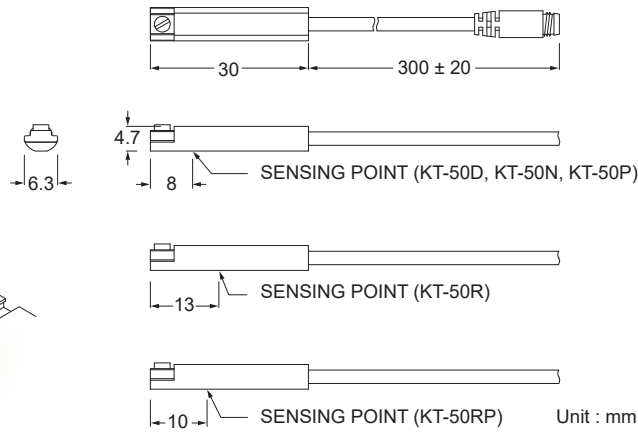

QD Pinout

3 wire QD wiring

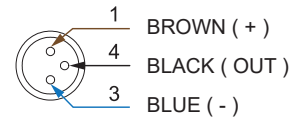

2 wire QD wiring

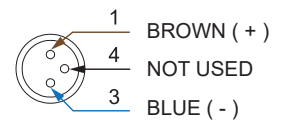

2 wire EQD wiring

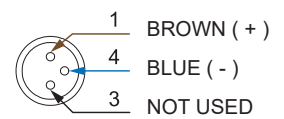

Specifications

MODEL	KT-50R	KT-50D	KT-50N	KT-50P	KT-50RP
Connect Diagram					
Characteristics	2-Wire Type		3-Wire Type		
Wiring Method	2-Wire Type		3-Wire Type		
Switching Logic	SPST, Normally Open	-	Solid State Output, Normally Open		SPST, Normally Open
Sensor Type	Reed Switch	-	NPN Current Sinking	PNP Current Sourcing	Reed Switch
Operating Voltage	5 ~ 240 V DC / AC	10 ~ 28 V DC	10 ~ 30 V DC		10 ~ 30 V DC / AC
Switching Current	100 mA max.	50 mA max.	200 mA max.		500 mA max.
Contact Rating ※1	10 W max.	1.5 W max.	6 W max.		10 W max.
Current Consumption	-		20 mA @ 24 V DC max.		5 mA @ 24 V DC max.
Voltage Drop	3.5 V max.		1.5 V max.		0.1 V @ 100 mA max.
Leakage Current	-	0.8 mA max.	0.05 mA max.		-
Indicator	Red LED			Yellow LED	
Cable	Ø3 PUR - 26 AWG (0.15 mm ²) - 2 cores		Ø3 PUR - 26 AWG (0.15 mm ²) - 3 cores		
Operating Frequency	200 Hz		1000 Hz		200 Hz
Magnet Requirement ※2			70 Gauss		
Temperature Range			-10 ~ 70 °C		
Shock ※3	30 G		50 G		30 G
Vibration ※4			9 G		
Enclosure Classification	IEC 60529 IP67				
Protection Circuit ※5	1	2, 4	2, 3, 4		1

NOTE

※1 : WARNING : Never exceed rating (Watt = Voltage x Amperage).
Permanent damage to sensor will occur.

※2 : Measuring standard target : Ø15.5 × Ø8 × 5t (Anisotropy rubber magnet)

※3 : Sin wave / X , Y , Z 3 directions / 3 times each direction / 11 ms each time.

※4 : Double amplitude 1.5 mm / 10 Hz ~ 55 Hz ~ 10 Hz (Sweep 1 min) / X , Y , Z 3 directions / 1 hour each time.

※5 : 1 = None / 2 = Short-circuit / 3 = Power Source Reverse polarity / 4 = Surge Suppression

Groove Dimensions | Clamp / Bracket

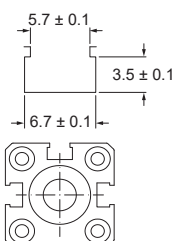

BL-1 Series

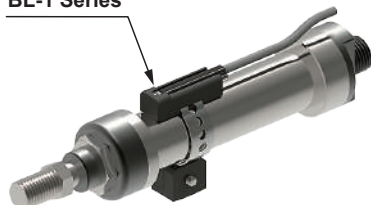

PF Series

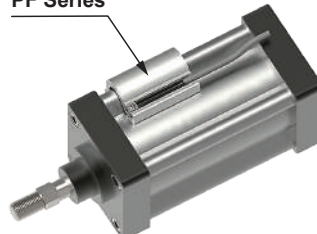

DT Series

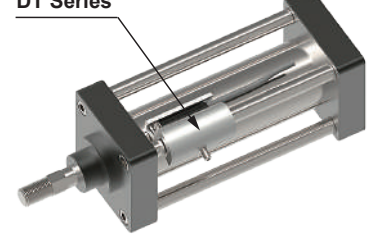

Unit : mm

KT-53 SERIES



Dimensions

KT-53R, KT-53D, KT-53DE, KT-53N, KT-53NE,
KT-53P, KT-53PE, KT-53RP /
KT-53R-QD, KT-53D-QD, KT-53DE-QD, KT-53N-QD,
KT-53NE-QD, KT-53P-QD, KT-53PE-QD, KT-53RP-QD

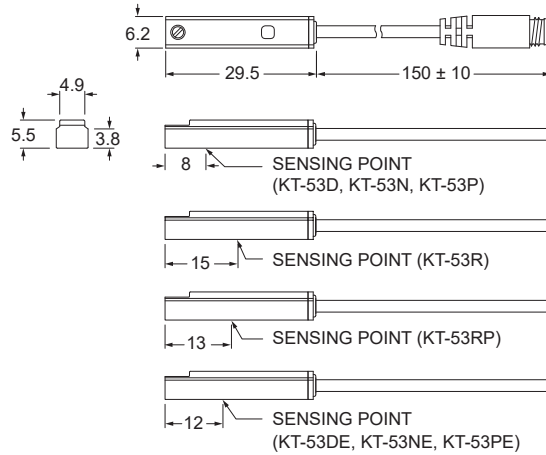

Unit : mm

QD Pinout

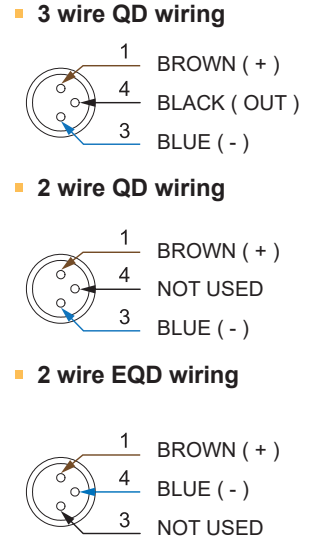

Specifications

MODEL	KT-53R	KT-53D	KT-53DE	KT-53N	KT-53NE	KT-53P	KT-53PE	KT-53RP
Connect Diagram								
Characteristics	2-Wire Type			3-Wire Type				
Wiring Method	2-Wire Type			3-Wire Type				
Switching Logic	SPST, Normally Open			Solid State Output, Normally Open				SPST, Normally Open
Sensor Type	Reed Switch	-		NPN Current Sinking		PNP Current Sourcing		Reed Switch
Operating Voltage	5 ~ 240 V DC / AC	10 ~ 28 V DC	5 ~ 30 V DC	10 ~ 30 V DC	5 ~ 30 V DC	10 ~ 30 V DC	5 ~ 30 V DC	10 ~ 30 V DC / AC
Switching Current	100 mA max.	50 mA max.		100 mA max.	200 mA max.	100 mA max.	200 mA max.	500 mA max.
Contact Rating ※1	10 W max.	1.5 W max.		3 W max.	6 W max.	3 W max.	6 W max.	10 W max.
Current Consumption	-			8 mA @ 24 V DC max.	6 mA @ 24 V DC max.	8 mA @ 24 V DC max.	6 mA @ 24 V DC max.	10 mA @ 24 V DC max.
Voltage Drop	3.5 V max.		3.7 V max.	1.5 V max.	0.5 V @ 200 mA max.	1.5 V max.	0.5 V @ 200 mA max.	0.1 V @ 100 mA max.
Leakage Current	-	0.8 mA max.	0.1 mA (40 uA) max.	0.01 mA max.				-
Indicator	Red LED					Yellow LED	Green LED	Yellow LED
Cable	Ø3 PUR - 26 AWG (0.15 mm ²) - 2 cores			Ø3 PUR - 26 AWG (0.15 mm ²) - 3 cores				
Operating Frequency	200 Hz	-			1000 Hz			200 Hz
Magnet Requirement ※2	70 Gauss	50 Gauss	40 ~ 1000 Gauss	50 Gauss	40 ~ 1000 Gauss	50 Gauss	40 ~ 1000 Gauss	70 Gauss
Temperature Range	-10 ~ 70 °C							
Shock ※3	30 G	-			50 G			30 G
Vibration ※4	9 G							
Enclosure Classification	IEC 60529 IP67							
Protection Circuit ※5	1	2, 4	3, 4	2, 3, 4	3, 4	2, 3, 4	3, 4	1

NOTE

※1 : WARNING : Never exceed rating (Watt = Voltage x Amperage).
Permanent damage to sensor will occur.

※2 : Measuring standard target : Ø15.5 × Ø8 × 5t (Anisotropy rubber magnet)

※3 : Sin wave / X , Y , Z 3 directions / 3 times each direction / 11 ms each time.

※4 : Double amplitude 1.5 mm / 10 Hz ~ 55 Hz ~ 10 Hz (Sweep 1 min) / X , Y , Z 3 directions / 1 hour each time.

※5 : 1 = None / 2 = Short-circuit / 3 = Power Source Reverse polarity / 4 = Surge Suppression

Groove Dimensions

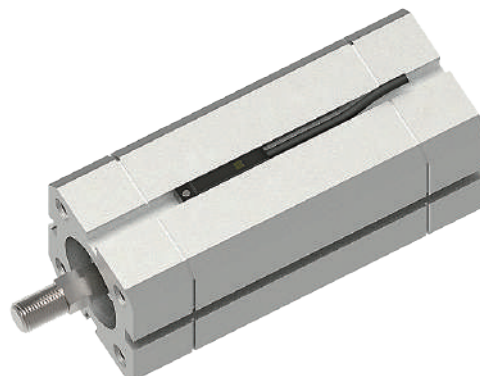
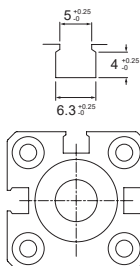

Unit : mm

KT-58 SERIES



Dimensions

KT-58R, KT-58N, KT-58P, KT-58RP / KT-58R-QD,
KT-58N-QD, KT-58P-QD, KT-58RP-QD

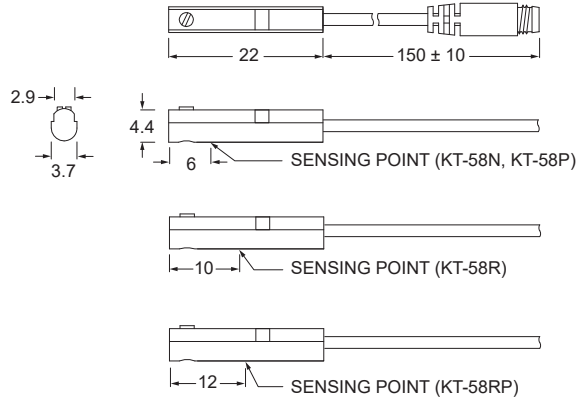

Unit : mm

QD Pinout

3 wire QD wiring

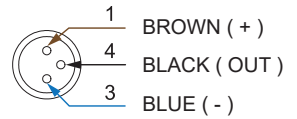

2 wire QD wiring

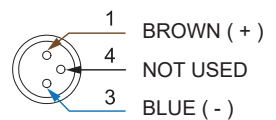

2 wire EQD wiring

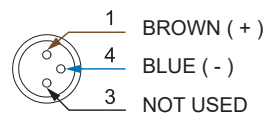

Specifications

MODEL	KT-58R	KT-58N	KT-58P	KT-58RP
Connect Diagram				
Characteristics				
Wiring Method	2-Wire Type	3-Wire Type		
Switching Logic	SPST, Normally Open	Solid State Output, Normally Open		SPST, Normally Open
Sensor Type	Reed Switch	NPN Current Sinking	PNP Current Sourcing	Reed Switch
Operating Voltage	5 ~ 120 V DC / AC	10 ~ 30 V DC		10 ~ 30 V DC / AC
Switching Current	100 mA max.	200 mA max.		500 mA max.
Contact Rating ※1	10 W max.	6 W max.		10 W max.
Current Consumption	-	10 mA @ 24 V DC max.		5 mA @ 24 V DC max.
Voltage Drop	3.5 V max.	0.5 V @ 50 mA max.		0.1 V @ 100 mA max.
Leakage Current	-	0.01 mA max.		-
Indicator	Red LED		Yellow LED	
Cable	Ø2.5 PUR - 28 AWG (0.082 mm ²) - 2 cores		Ø2.5 PUR - 28 AWG (0.082 mm ²) - 3 cores	
Operating Frequency	200 Hz	1000 Hz		200 Hz
Magnet Requirement ※2	70 Gauss	40 Gauss		50 Gauss
Temperature Range	-10 ~ 70 °C			
Shock ※3	30 G	50 G		30 G
Vibration ※4	9 G			
Enclosure Classification	IEC 60529 IP67			
Protection Circuit ※5	1	3, 4		1

NOTE

※1 : WARNING : Never exceed rating (Watt = Voltage x Amperage).

Permanent damage to sensor will occur.

※2 : Measuring standard target : Ø15.5 × Ø8 × 5t (Anisotropy rubber magnet)

※3 : Sin wave / X , Y , Z 3 directions / 3 times each direction / 11 ms each time.

※4 : Double amplitude 1.5 mm / 10 Hz ~ 55 Hz ~ 10 Hz (Sweep 1 min) / X , Y , Z 3 directions / 1 hour each time.

※5 : 1 = None / 2 = Short-circuit / 3 = Power Source Reverse polarity / 4 = Surge Suppression

Groove Dimensions

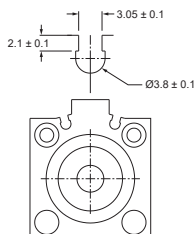

Unit : mm

KT-59 SERIES



Dimensions

KT-59R, KT-59N, KT-59P, KT-59RP /
KT-59R-QD, KT-59N-QD, KT-59P-QD, KT-59RP-QD

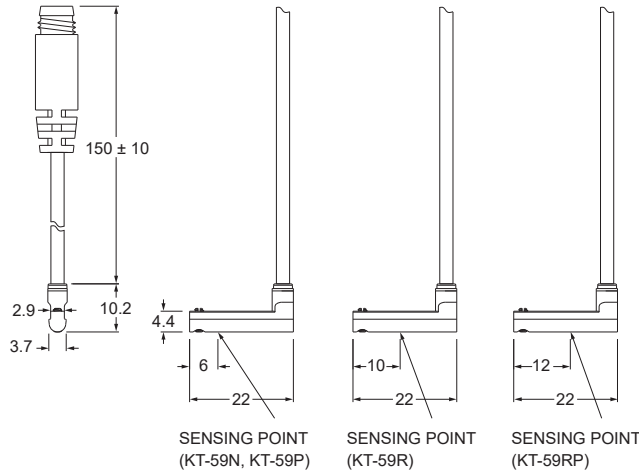

Unit : mm

QD Pinout

3 wire QD wiring

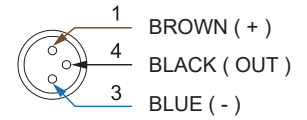

2 wire QD wiring

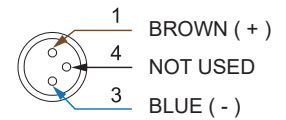

2 wire EQD wiring

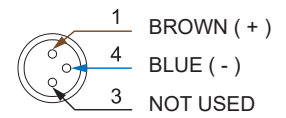

Specifications

MODEL	KT-59R	KT-59N	KT-59P	KT-59RP
Connect Diagram				
Characteristics				
Wiring Method	2-Wire Type	3-Wire Type		
Switching Logic	SPST, Normally Open	Solid State Output, Normally Open		SPST, Normally Open
Sensor Type	Reed Switch	NPN Current Sinking	PNP Current Sourcing	Reed Switch
Operating Voltage	5 ~ 120 V DC / AC	10 ~ 30 V DC		10 ~ 30 V DC / AC
Switching Current	100 mA max.	200 mA max.		500 mA max.
Contact Rating ※1	10 W max.	6 W max.		10 W max.
Current Consumption	-	10 mA @ 24 V DC max.		5 mA @ 24 V DC max.
Voltage Drop	3.5 V max.	0.5 V @ 50 mA max.		0.1 V @ 100 mA max.
Leakage Current	-	0.01 mA max.		-
Indicator	Red LED		Yellow LED	
Cable	Ø2.5 PUR - 28 AWG (0.082 mm ²) - 2 cores		Ø2.5 PUR - 28 AWG (0.082 mm ²) - 3 cores	
Operating Frequency	200 Hz	1000 Hz		200 Hz
Magnet Requirement ※2	70 Gauss	40 Gauss		50 Gauss
Temperature Range	-10 ~ 70 °C			
Shock ※3	30 G	50 G		30 G
Vibration ※4	9 G			
Enclosure Classification	IEC 60529 IP67			
Protection Circuit ※5	1	3, 4		1

NOTE

※1 : WARNING : Never exceed rating (Watt = Voltage x Amperage).
Permanent damage to sensor will occur.

※2 : Measuring standard target : Ø15.5 × Ø8 × 5t (Anisotropy rubber magnet)

※3 : Sin wave / X , Y , Z 3 directions / 3 times each direction / 11 ms each time.

※4 : Double amplitude 1.5 mm / 10 Hz ~ 55 Hz ~ 10 Hz (Sweep 1 min) / X , Y , Z 3 directions / 1 hour each time.

※5 : 1 = None / 2 = Short-circuit / 3 = Power Source Reverse polarity / 4 = Surge Suppression

Groove Dimensions

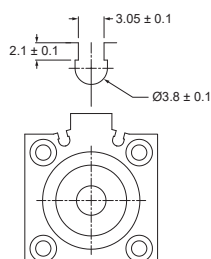

Unit : mm

KT-65 SERIES



Patented

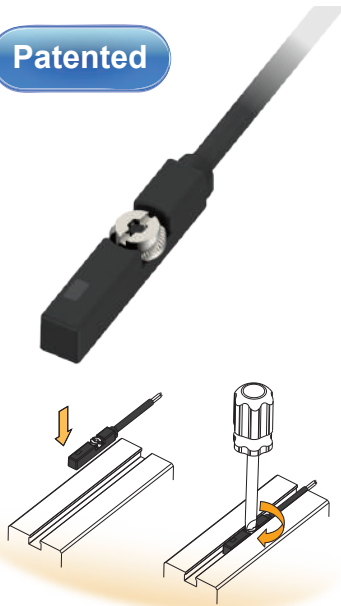

Dimensions

KT-65D, KT-65DE, KT-65N, KT-65NE, KT-65P, KT-65PE /
KT-65D-QD, KT-65DE-QD, KT-65N-QD, KT-65NE-QD,
KT-65P-QD, KT-65PE-QD

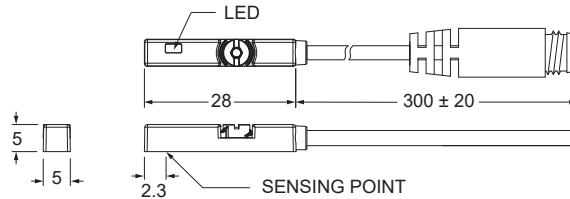

KT-65R, KT-65RP / KT-65R-QD, KT-65RP-QD

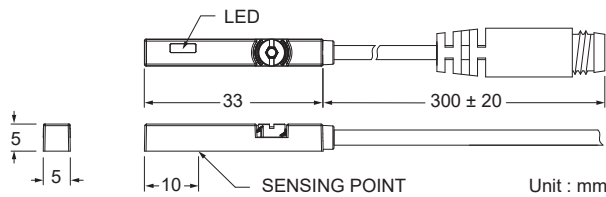

QD Pinout

3 wire QD wiring

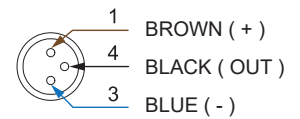

2 wire QD wiring

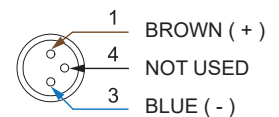

2 wire EQD wiring

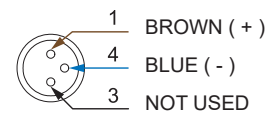

Specifications

MODEL	KT-65R	KT-65D	KT-65DE	KT-65N	KT-65NE	KT-65P	KT-65PE	KT-65RP	
Connect Diagram									
Characteristics	2-Wire Type			3-Wire Type					
Wiring Method	2-Wire Type			3-Wire Type					
Switching Logic	SPST, Normally Open	Solid State Output, Normally Open			SPST, Normally Open				
Sensor Type	Reed Switch	-			NPN Current Sinking		PNP Current Sourcing		
Operating Voltage	5 ~ 240 V DC / AC	10 ~ 28 V DC	5 ~ 30 V DC	10 ~ 28 V DC	5 ~ 30 V DC	10 ~ 28 V DC	5 ~ 30 V DC	10 ~ 30 V DC / AC	
Switching Current	100 mA max.	50 mA max.			200 mA max.			500 mA max.	
Contact Rating ※1	10 W max.	1.5 W max.			5.5 W max.	6 W max.	5.5 W max.	6 W max.	10 W max.
Current Consumption	-			10 mA @ 24 V DC max.	6 mA @ 24 V DC max.	10 mA @ 24 V DC max.	6 mA @ 24 V DC max.	10 mA @ 24 V DC max.	
Voltage Drop	3.0 V max.	3.5 V max.	3.7 V max.	1.5 V max.	0.5 V @ 200 mA max.	1.5 V max.	0.5 V @ 200 mA max.	0.1 V @ 100 mA max.	
Leakage Current	-	0.8 mA max.	0.1 mA (40 uA) max.	0.05 mA max.	0.01 mA max.	0.05 mA max.	0.01 mA max.	-	
Indicator	Red LED				Yellow LED				
Cable	Ø2.8 PUR - 26 AWG (0.15 mm ²) - 2 cores			Ø2.8 PUR - 26 AWG (0.15 mm ²) - 3 cores					
Operating Frequency	200 Hz	1000 Hz max.						200 Hz	
Magnet Requirement ※2	75 Gauss	50 Gauss	40 ~ 1000 Gauss	50 Gauss	40 ~ 1000 Gauss	50 Gauss	40 ~ 1000 Gauss	65 Gauss	
Temperature Range	-10 ~ 70 °C								
Shock ※3	30 G	50 G						30 G	
Vibration ※4	9 G								
Enclosure Classification	IEC 60529 IP67								
Protection Circuit ※5	1	2, 4	3, 4	2, 3, 4	3, 4	2, 3, 4	3, 4	1	

NOTE

※1 : WARNING : Never exceed rating (Watt = Voltage x Amperage).
Permanent damage to sensor will occur.

※2 : Measuring standard target : Ø15.5 × Ø8 × 5t (Anisotropy rubber magnet)

※3 : Sin wave / X , Y , Z 3 directions / 3 times each direction / 11 ms each time.

※4 : Double amplitude 1.5 mm / 10 Hz ~ 55 Hz ~ 10 Hz (Sweep 1 min) / X , Y , Z 3 directions / 1 hour each time.

※5 : 1 = None / 2 = Short-circuit / 3 = Power Source Reverse polarity / 4 = Surge Suppression

Groove Dimensions | Clamp / Bracket

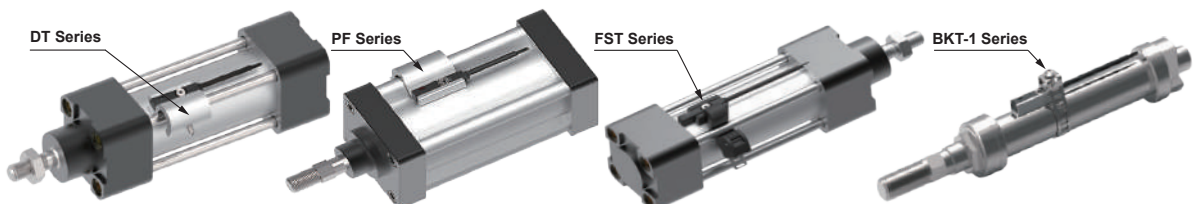
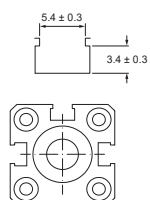

Unit : mm

KT-65-EX SERIES



Explosion Proof

Patented

Dimensions

KT-65N-EX, KT-65N-NC-EX, KT-65P-EX,
KT-65P-NC-EX, KT-65D-EX

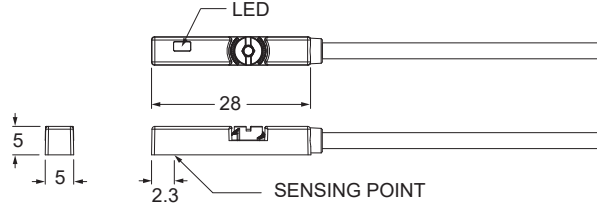

KT-65R-EX, KT-65RP-EX

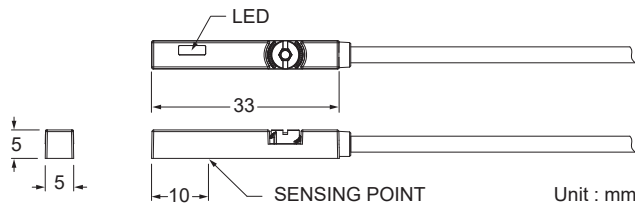

M8 Connector option is not available

Specifications

MODEL	KT-65R-EX	KT-65D-EX	KT-65N-EX	KT-65N-NC-EX	KT-65P-EX	KT-65P-NC-EX	KT-65RP-EX	
Connect Diagram								
Characteristics	2-Wire Type		3-Wire Type					
Wiring Method	2-Wire Type		3-Wire Type					
Switching Logic	SPST, Normally Open	Solid State Output, Normally Open	Solid State Output, Normally Close	Solid State Output, Normally Open	Solid State Output, Normally Close	SPST, Normally Open	SPST, Normally Open	
Sensor Type	Reed Switch	-	NPN Current Sinking		PNP Current Sourcing		Reed Switch	
Operating Voltage	5 ~ 30 V DC / AC		10 ~ 28 V DC				10 ~ 30 V DC / AC	
Switching Current	100 mA max.	50 mA max.	200 mA max.		500 mA max.		10 W max.	
Contact Rating ※1	10 W max.	1.5 W max.	5.5 W max.		10 W max.		10 W max.	
Current Consumption	-		10 mA @ 24 V DC max.					
Voltage Drop	3.0 V max.	3.5 V max.	1.5 V max.		0.1 V @ 100 mA max.		-	
Leakage Current	-	0.8 mA max.	0.05 mA max.		-			
Indicator	Red LED				Yellow LED			
Cable	Ø2.8 PUR - 26 AWG (0.15 mm ²) - 2 cores		Ø2.8 PUR - 26 AWG (0.15 mm ²) - 3 cores					
Operating Frequency	200 Hz	1000 Hz		200 Hz		65 Gauss		
Magnet Requirement ※2	65 Gauss	50 Gauss		30 G		9 G		
Temperature Range	-10 ~ 70 °C		IEC 60529 IP67		1			
Shock ※3	30 G	50 G		2, 3, 4		1		
Vibration ※4	9 G		1					
Enclosure Classification	1		2		2, 3, 4		1	
Protection Circuit ※5	1		2		2, 3, 4		1	
CE ATEX APPROVAL Baseefa14ATEX0118	Ⓔ II 3GD Ex ic IIB T4 Gc (-10 °C ≤ Ta ≤ +70 °C) Ex ic IIIC T135 °C Dc (-10 °C ≤ Ta ≤ +70 °C)							

NOTE

※1 : WARNING : Never exceed rating (Watt = Voltage x Amperage).
Permanent damage to sensor will occur.

※2 : Measuring standard target : Ø15.5 × Ø8 × 5t (Anisotropy rubber magnet)

※3 : Sin wave / X , Y , Z 3 directions / 3 times each direction / 11 ms each time.

※4 : Double amplitude 1.5 mm / 10 Hz ~ 55 Hz ~ 10 Hz (Sweep 1 min) / X , Y , Z 3 directions / 1 hour each time.

※5 : 1 = None / 2 = Short-circuit / 3 = Power Source Reverse polarity / 4 = Surge Suppression

Groove Dimensions | Clamp / Bracket

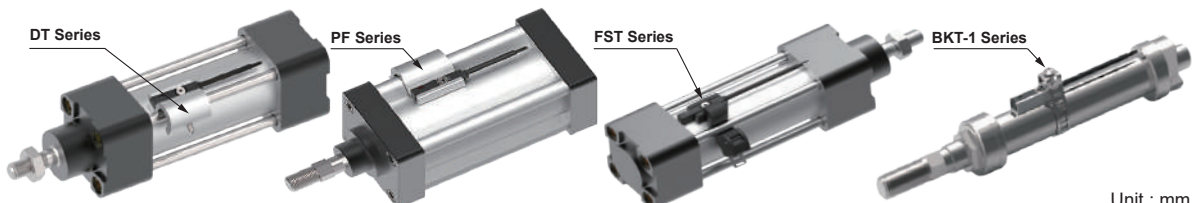
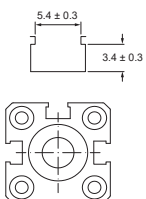

Unit : mm

KT-65-UL SERIES



Patented

Dimensions

M8 Connector option is not available

KT-65N-UL, KT-65P-UL, KT-65D-UL

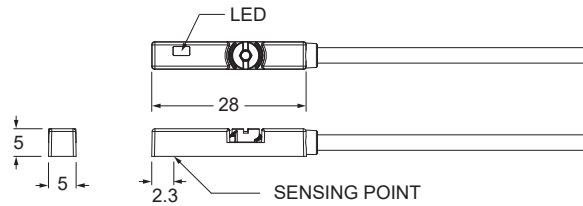

KT-65R-UL, KT-65RP-UL

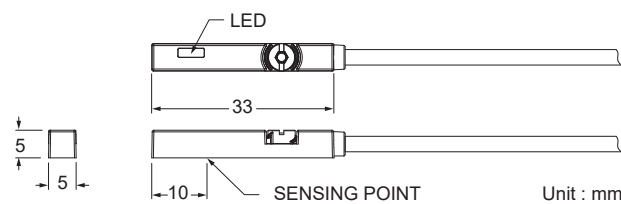

Unit : mm

Specifications

MODEL	KT-65R-UL	KT-65D-UL	KT-65N-UL	KT-65P-UL	KT-65RP-UL
Connect Diagram					
Characteristics	2-Wire Type		3-Wire Type		
Wiring Method	2-Wire Type		3-Wire Type		
Switching Logic	SPST, Normally Open		Solid State Output, Normally Open		SPST, Normally Open
Sensor Type	Reed Switch	-	NPN Current Sinking	PNP Current Sourcing	Reed Switch
Operating Voltage	5 ~ 30 V DC / AC		10 ~ 28 V DC		10 ~ 30 V DC / AC
Switching Current	60 mA max.	40 mA max.	100 mA max.		
Contact Rating ※1	1.8 W max.	1.2 W max.	3 W max.		
Current Consumption			10 mA @ 24 V DC max.		
Voltage Drop	3.0 V max.	3.5 V max.	1.5 V max.		0.1 V @ 100 mA max.
Leakage Current	-	0.8 mA max.	0.05 mA max.		-
Indicator	Red LED			Yellow LED	
Cable	Ø2.8 PUR - 26 AWG (0.15 mm ²) - 2 cores		Ø2.8 PUR - 26 AWG (0.15 mm ²) - 3 cores		
Operating Frequency	200 Hz		1000 Hz		200 Hz
Magnet Requirement ※2	75 Gauss		50 Gauss		65 Gauss
Temperature Range	-10 ~ 60 °C		-10 ~ 70 °C		
Shock ※3	30 G		50 G		30 G
Vibration ※4	9 G				
Enclosure Classification	IEC 60529 IP67				
Protection Circuit ※5	1	2	2, 3, 4		1

NOTE

※1 : WARNING : Never exceed rating (Watt = Voltage x Amperage).
Permanent damage to sensor will occur.

※2 : Measuring standard target : Ø15.5 × Ø8 × 5t (Anisotropy rubber magnet)

※3 : Sin wave / X , Y , Z 3 directions / 3 times each direction / 11 ms each time.

※4 : Double amplitude 1.5 mm / 10 Hz ~ 55 Hz ~ 10 Hz (Sweep 1 min) / X , Y , Z 3 directions / 1 hour each time.

※5 : 1 = None / 2 = Short-circuit / 3 = Power Source Reverse polarity / 4 = Surge Suppression

Groove Dimensions | Clamp / Bracket

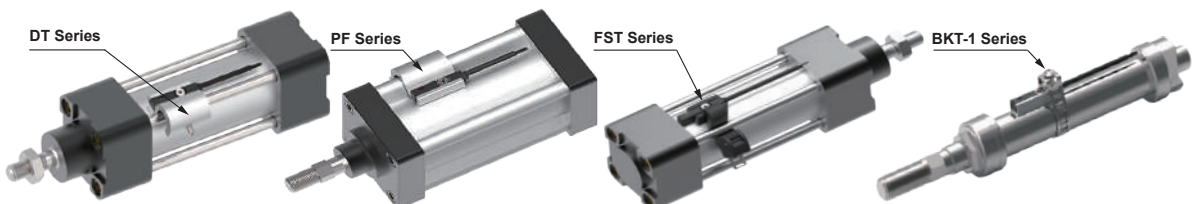
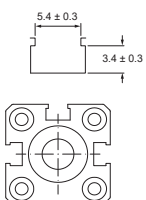

Unit : mm

KT-71 SERIES



Dimensions

KT-71D, KT-71N, KT-71P /
KT-71D-QD, KT-71N-QD, KT-71P-QD

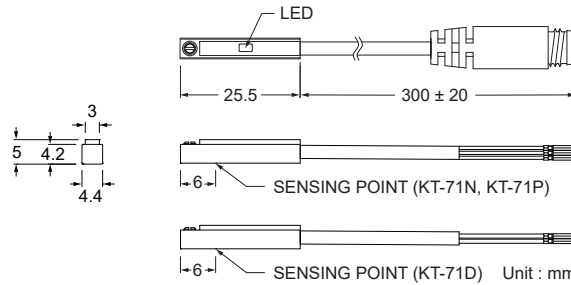

SW Out

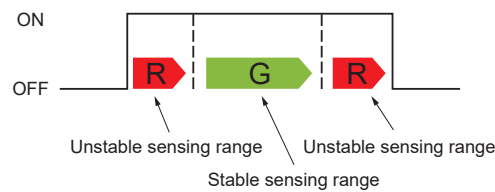

- Dual Color LED allow more precise positioning

QD Pinout

3 wire QD wiring

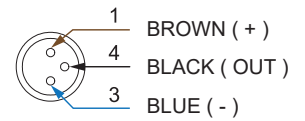

2 wire QD wiring

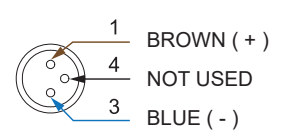

2 wire EQD wiring

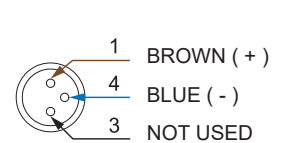

Specifications

MODEL	KT-71D	KT-71N	KT-71P
Connect Diagram			
Characteristics	-		
Wiring Method	2-Wire Type	3-Wire Type	
Switching Logic	Solid State Output, Normally Open		
Sensor Type	-	NPN Current Sinking	PNP Current Sourcing
Operating Voltage	10 ~ 28 V DC		
Switching Current	80 mA max.		
Contact Rating ※1	2 W max.		
Current Consumption	-	10 mA @ 24 V DC max.	
Voltage Drop	4 V max.	1.5 V max.	
Leakage Current	1 mA max.	0.05 mA max.	
Indicator	Red LED : unstable sensing range ; Green LED : stable sensing range		
Cable	Ø2.8 PUR - 26AWG (0.15 mm ²) - 2 cores	Ø2.8 PUR - 26AWG (0.15 mm ²) - 3 cores	
Operating Frequency	1000 Hz		
Magnet Requirement ※2	85 Gauss		
Temperature Range	-10 ~ 60 °C		
Shock ※3	50 G		
Vibration ※4	9 G		
Enclosure Classification	IEC 60529 IP67		
Protection Circuit ※5	2, 3, 4		

NOTE

※1 : WARNING : Never exceed rating (Watt = Voltage x Amperage).
Permanent damage to sensor will occur.

※2 : Measuring standard target : Ø15.5 × Ø8 × 5t (Anisotropy rubber magnet)

※3 : Sin wave / X , Y , Z 3 directions / 3 times each direction / 11 ms each time.

※4 : Double amplitude 1.5 mm / 10 Hz ~ 55 Hz ~ 10 Hz (Sweep 1 min) / X , Y , Z 3 directions / 1 hour each time.

※5 : 1 = None / 2 = Short-circuit / 3 = Power Source Reverse polarity / 4 = Surge Suppression

Groove Dimensions

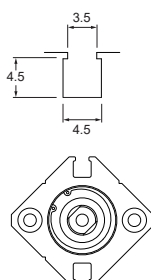

Unit : mm

KT-75 SERIES



Patented



Dimensions

KT-75D, KT-75N, KT-75P / KT-75D-QD, KT-75N-QD, KT-75P-QD

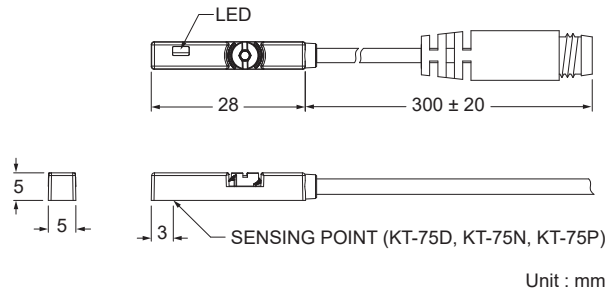

Unit : mm

SW Out

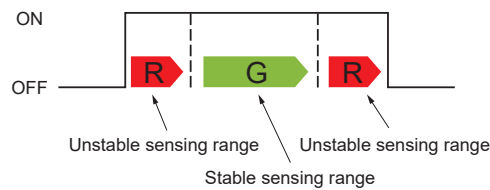

QD Pinout

3 wire QD wiring

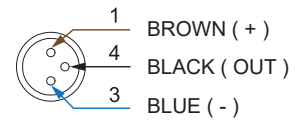

2 wire QD wiring

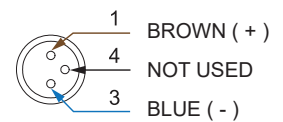

2 wire EQD wiring

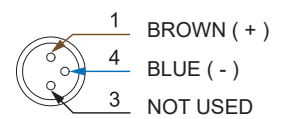

- Dual Color LED allow more precise positioning

Specifications

MODEL	KT-75D	KT-75N	KT-75P
Connect Diagram			
Characteristics			
Wiring Method	2-Wire Type	3-Wire Type	
Switching Logic	Solid State Output, Normally Open		
Sensor Type	-	NPN Current Sinking	PNP Current Sourcing
Operating Voltage	10 ~ 28 V DC		
Switching Current	80 mA max.		
Contact Rating ※1	2 W max.		
Current Consumption	-	10 mA @ 24 V DC max.	
Voltage Drop	4 V max.	1.5 V max.	
Leakage Current	1 mA max.	0.05 mA max.	
Indicator	Red LED : unstable sensing range ; Green LED : stable sensing range		
Cable	Ø2.8 PUR - 26 AWG (0.15 mm ²) - 2 cores	Ø2.8 PUR - 26 AWG (0.15 mm ²) - 3 cores	
Operating Frequency	1000 Hz		
Magnet Requirement ※2	85 Gauss		
Temperature Range	-10 ~ 60 °C		
Shock ※3	50 G		
Vibration ※4	9 G		
Enclosure Classification	IEC 60529 IP67		
Protection Circuit ※5	2, 3, 4		

NOTE

※1 : WARNING : Never exceed rating (Watt = Voltage x Amperage). Permanent damage to sensor will occur.

※2 : Measuring standard target : Ø15.5 × Ø8 × 5t (Anisotropy rubber magnet)

※3 : Sin wave / X, Y, Z 3 directions / 3 times each direction / 11 ms each time.

※4 : Double amplitude 1.5 mm / 10 Hz ~ 55 Hz ~ 10 Hz (Sweep 1 min) / X, Y, Z 3 directions / 1 hour each time.

※5 : 1 = None / 2 = Short-circuit / 3 = Power Source Reverse polarity / 4 = Surge Suppression

Groove Dimensions

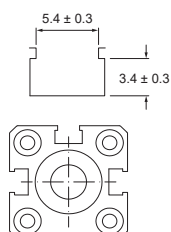

Clamp

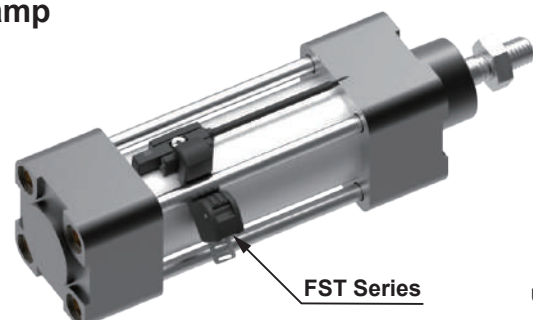

Unit : mm

KT-77 SERIES



Dimensions

KT-77D, KT-77N, KT-77P /
KT-77D-QD, KT-77N-QD, KT-77P-QD

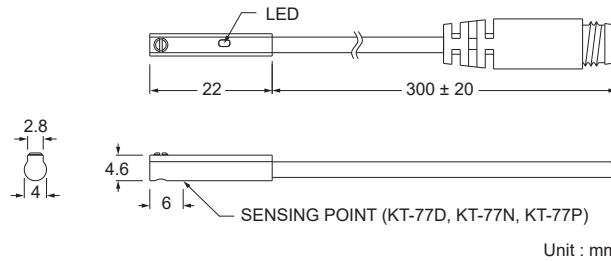

SW Out

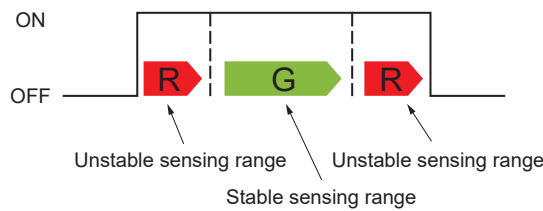

QD Pinout

3 wire QD wiring

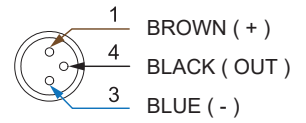

2 wire QD wiring

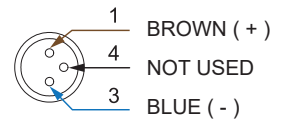

2 wire EQD wiring

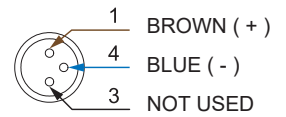

- Dual Color LED allow more precise positioning

Specifications

MODEL	KT-77D	KT-77N	KT-77P
Connect Diagram			
Characteristics			
Wiring Method	2-Wire Type	3-Wire Type	
Switching Logic	Solid State Output, Normally Open		
Sensor Type	-	NPN Current Sinking	PNP Current Sourcing
Operating Voltage	10 ~ 28 V DC		
Switching Current	80 mA max.		
Contact Rating ※1	2 W max.		
Current Consumption	-	10 mA @ 24 V DC max.	
Voltage Drop	4 V max.	1.5 V max.	
Leakage Current	1 mA max.	0.05 mA max.	
Indicator	Red LED : unstable sensing range ; Green LED : stable sensing range		
Cable	Ø2.8 PUR - 26 AWG (0.15 mm ²) - 2 cores	Ø2.8 PUR - 26 AWG (0.15 mm ²) - 3 cores	
Operating Frequency	1000 Hz		
Magnet Requirement ※2	85 Gauss		
Temperature Range	-10 ~ 60 °C		
Shock ※3	50 G		
Vibration ※4	9 G		
Enclosure Classification	IEC 60529 IP67		
Protection Circuit ※5	2, 3, 4		

NOTE

※1 : WARNING : Never exceed rating (Watt = Voltage x Amperage).
Permanent damage to sensor will occur.

※2 : Measuring standard target : Ø15.5 × Ø8 × 5t (Anisotropy rubber magnet)

※3 : Sin wave / X , Y , Z 3 directions / 3 times each direction / 11 ms each time.

※4 : Double amplitude 1.5 mm / 10 Hz ~ 55 Hz ~ 10 Hz (Sweep 1 min) / X , Y , Z 3 directions / 1 hour each time.

※5 : 1 = None / 2 = Short-circuit / 3 = Power Source Reverse polarity / 4 = Surge Suppression

Groove Dimensions

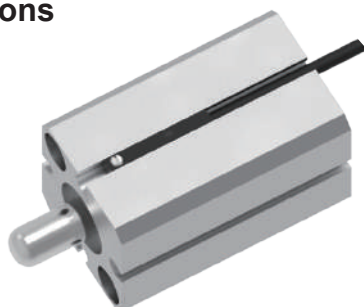
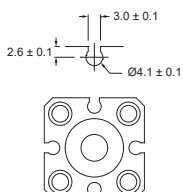

Clamp

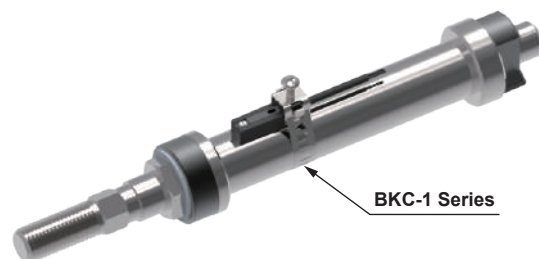

Unit : mm

KT-1000D SERIES

Weld-field Immune Sensor



Magnetic Field Resistant



Dimensions

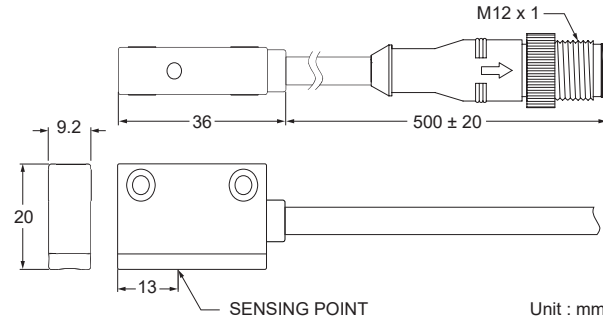

QD Pinout

QD

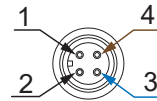

- 1 : N / C (No connect)
- 2 : N / C (No connect)
- 3 : BLUE
- 4 : BROWN

EQD

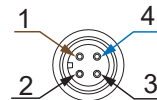

- 1 : BROWN
- 2 : N / C (No connect)
- 3 : N / C (No connect)
- 4 : BLUE

- Dual Color LED allow more precise positioning

SW Out

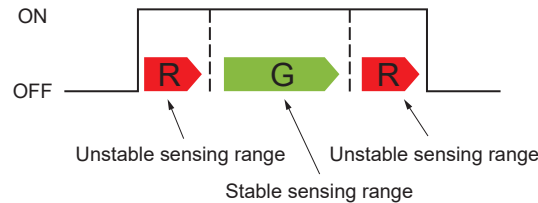

Specifications

MODEL	KT-1000D
Connect Diagram	
Characteristics	
Wiring Method	2-Wire Type
Switching Logic	Solid State Output, Normally Open
Sensor Type	-
Operating Voltage	10 ~ 28 V DC
Switching Current	5 ~ 50 mA max.
Contact Rating ※1	1.5 W max.
Current Consumption	-
Voltage Drop	5 V max.
Leakage Current	1 mA max.
Indicator	Red LED : unstable sensing range ; Green LED : stable sensing range
Cable	Ø5.4 PVC - 20 AWG (0.5 mm ²) - 2 cores
Operating Time	50 ms max.
Magnetic Field Resistance ※2	16000 A
Magnet Requirement ※3	85 Gauss
Temperature Range	-10 ~ 60 °C
Shock ※4	30 G
Vibration ※5	9 G
Enclosure Classification	IEC 60529 IP67
Protection Circuit ※6	3, 4

NOTE

- ※1 : WARNING : Never exceed rating (Watt = Voltage × Amperage). Permanent damage to sensor will occur.
- ※2 : The operational distance can be 0 mm between KT-1000D and welding gun (welding conductor or cable) when the welding current less than 16000 A.
- ※3 : Measuring standard target : Ø15.5 × Ø8 × 5t (Anisotropy rubber magnet)
- ※4 : Sin wave / X , Y , Z 3 directions / 3 times each direction / 11 ms each time.
- ※5 : Double amplitude 1.5 mm / 10 Hz ~ 55 Hz ~ 10 Hz (Sweep 1 min) / X , Y , Z 3 directions / 1 hour each time.
- ※6 : 1 = None / 2 = Short-circuit / 3 = Power Source Reverse polarity / 4 = Surge Suppression

Ordering Information

KT - 1000D -

Cable Length / Connector

- Blank : With 3 meter cable
- QD : With M12 4Pin male connector

Application Mounting

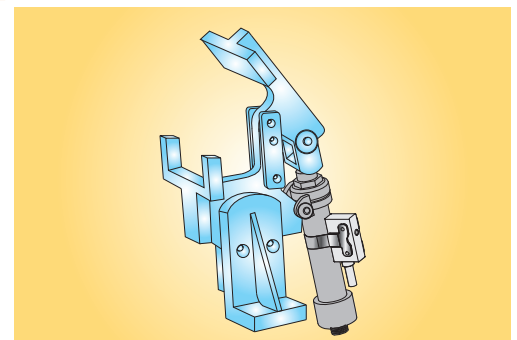

- KT-1000D detects the position of the cylinder piston and it is especially suitable for clamp cylinder.

BP Clamp

Clamp is designed for mounting KT-1000D on round cylinder.

How to Mount

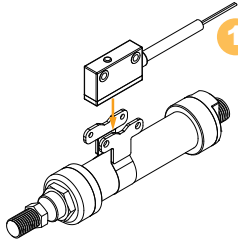

1 Step 1

Wrap the band around cylinder, and place sensor on cylinder.

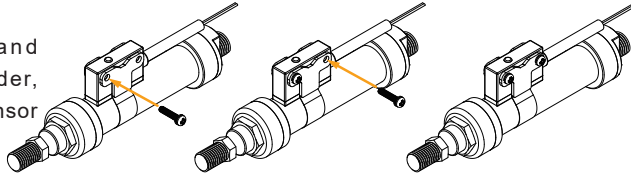

2 Step 2

Insert screw into clamp. Adjust sensor to the sensing position and tighten.

B P - 4 0 4 5

Cylinder I.D.

- 40 : Ø40 round cylinder
- 50 : Ø50 round cylinder
- 63 : Ø63 round cylinder

Cylinder O.D.

- 45 : Ø45 round cylinder
- 47 : Ø47 round cylinder
- ⋮
- 72 : Ø72 round cylinder

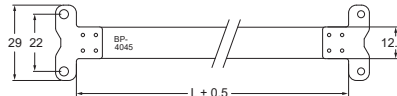

Cylinder Chart

MODEL	"L"	I.D.	O.D.
BP-4045	154	Ø40	Ø45
BP-4047	161	Ø40	Ø47
BP-5055	188	Ø50	Ø55
BP-5058	197	Ø50	Ø58
BP-6368	228	Ø63	Ø68
BP-6372	240	Ø63	Ø72

Unit : mm

PMB Bracket

Bracket is designed for mounting KT-1000D on round cylinder.

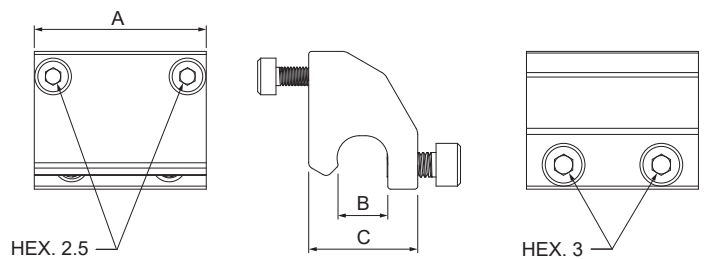
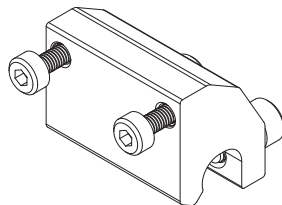
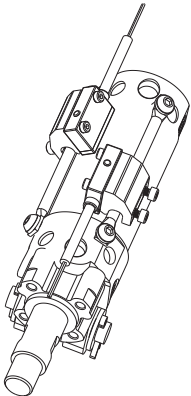

MODEL	DIM.	A	B	C
PMB-040		28.15	8.15	17.85

Unit : mm

Application Environment



- KT-1000D can be applied in the strong magnetic field environment such as automotive manufacturing or areas near welding machine.
- When KT-1000D detects the magnetic AC field (50 or 60 Hz) it will keep the status of output and will not be effected.

Weld-Field Immune

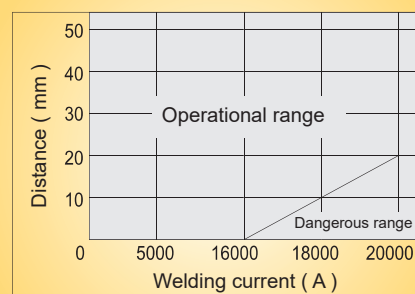

- The operational distance can be 0 mm between KT-1000D and welding gun (welding conductor or cable) when the welding current less than 16000 A.

KT-1001D SERIES

Weld-field Immune Sensor



Magnetic Field Resistant

Dimensions

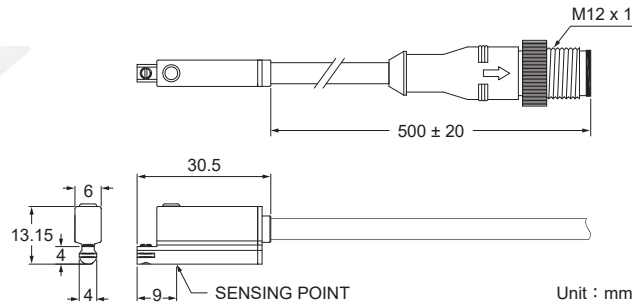

QD Pinout

QD

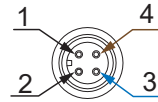

- 1 : N / C (No connect)
- 2 : N / C (No connect)
- 3 : BLUE
- 4 : BROWN

EQD

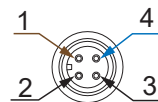

- 1 : BROWN
- 2 : N / C (No connect)
- 3 : N / C (No connect)
- 4 : BLUE

SW Out

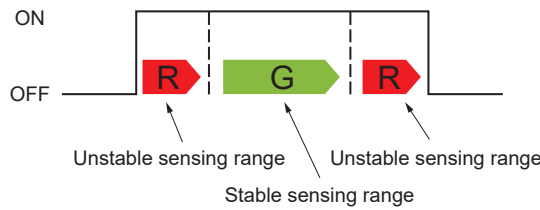

- Dual Color LED allow more precise positioning

Specifications

MODEL	KT-1001D
Connect Diagram	
Characteristics	
Wiring Method	2-Wire Type
Switching Logic	Solid State Output, Normally Open
Sensor Type	-
Operating Voltage	10 ~ 28 V DC
Switching Current	5 ~ 50 mA max.
Contact Rating ※1	1.5 W max.
Current Consumption	-
Voltage Drop	5 V max.
Leakage Current	1 mA max.
Indicator	Red LED : unstable sensing range ; Green LED : stable sensing range
Cable	∅4.8 PVC - 20 AWG (0.5 mm ²) - 2 cores
Operating Time	50 ms max.
Magnetic Feild Resistance ※2	16000 A
Magnet Requirement ※3	85 Gauss
Temperature Range	-10 ~ 60 °C
Shock ※4	50 G
Vibration ※5	9 G
Enclosure Classification	IEC 60529 IP67
Protection Circuit ※6	3, 4

NOTE

- ※1 : WARNING : Never exceed rating (Watt = Voltage × Amperage). Permanent damage to sensor will occur.
- ※2 : The operational distance can be 0 mm between KT-1001D and welding gun (welding conductor or cable) when the welding current less than 16000 A.
- ※3 : Measuring standard target : ∅15.5 × ∅8 × 5t (Anisotropy rubber magnet)
- ※4 : Sin wave / X , Y , Z 3 directions / 3 times each direction / 11 ms each time.
- ※5 : Double amplitude 1.5 mm / 10 Hz ~ 55 Hz ~ 10 Hz (Sweep 1 min) / X , Y , Z 3 directions / 1 hour each time.
- ※6 : 1 = None / 2 = Short-circuit / 3 = Power Source Reverse polarity / 4 = Surge Suppression

Ordering Information

KT - 1001D -

Cable Length / Connector

- Blank: With 3 meter cable
- QD: With M12 4Pin male connector

Groove Dimensions

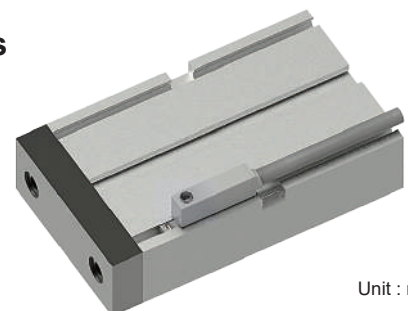
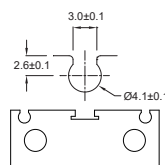

Unit : mm

BRACKET SERIES



PM Series

Bracket is designed for mounting KT-20 & KT-21 & KT-31 series sensor on Tie-Rod cylinder.

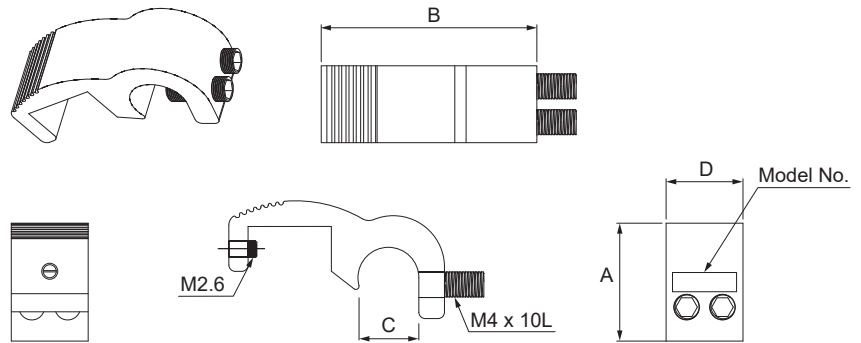
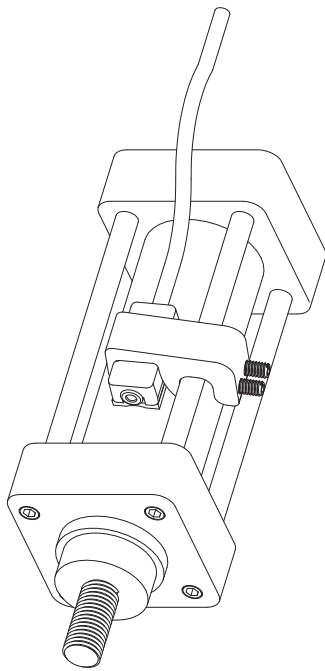

MODEL	DIM.	A	B	C	D
PM-6		19.1	31.8	7.3	12
PM-8		18.4	33.7	9.3	12
PM-10		16.7	35.9	11.2	12
PM-12		20	35.5	11.5	12
PM-14		24	38.0	13.5	12
PM-16		24	40.0	15.5	12

Unit : mm

PI Series

Bracket is designed for mounting KT-20 & KT-21 & KT-31 series sensor on ISO profile cylinder.

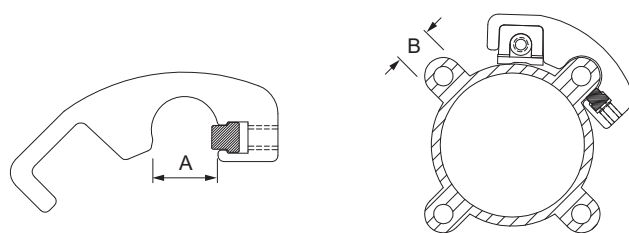
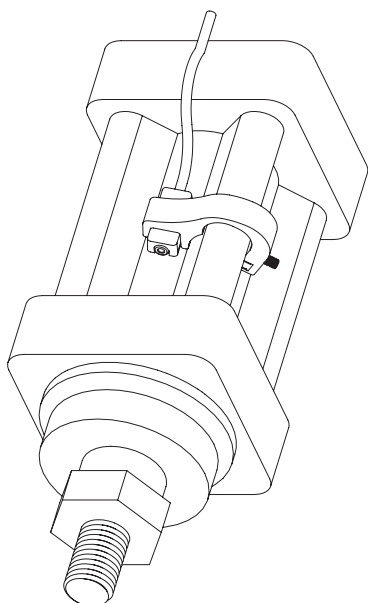

MODEL	DIM.	A	B	Remark
PI-1		10.9	10.4	Ø32 ~ Ø40
PI-2		14.10	13.5	Ø50 ~ Ø63
PI-3		15.45	15	Ø80
PI-4		16.3	16	Ø100
PI-5		19.8	18.7	Ø125
PI-6		26.5	25.7	Ø150

Unit : mm

PF Series

Bracket is designed for mounting KT-32 & KT-40 & KT-50 & KT-65 & KT-75 series sensor on ISO profile cylinder.

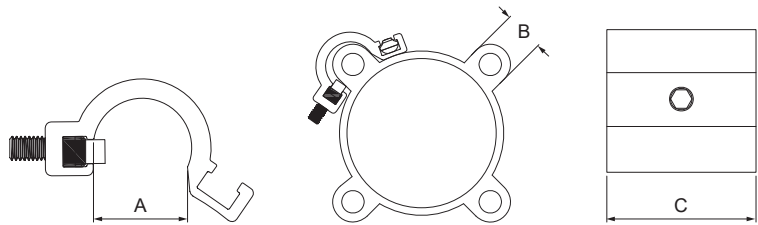
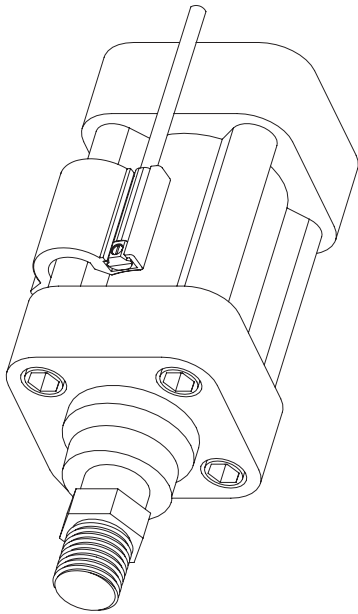

MODEL	DIM.	A	B	C	Remark
PF-1		12.1	10.4	25	Ø32 ~ Ø40
PF-2		15.9	13.5	25	Ø50 ~ Ø63
PF-3		16.3	15	25	Ø80
PF-4		17.9	16	25	Ø100
PF-5		19.7	18.7	25	Ø125

Unit : mm

DT Series

Bracket is designed for mounting KT-32 & KT-40 & KT-50 & KT-65 & KT-75 series sensor on Tie-Rod cylinder.

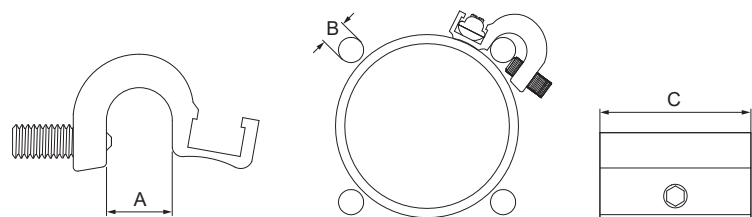
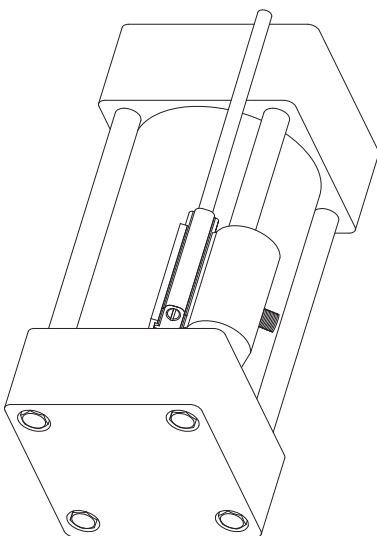

MODEL	DIM.	A	B	C
DT-1		7.9	Ø4 ~ Ø6	25
DT-2		10.4	Ø8 ~ Ø10	25
DT-3		15.1	Ø12 ~ Ø14	25
DT-4		20.6	Ø16	25
DT-5		24.9	Ø20 ~ Ø24	30

Unit : mm

BRACKET SERIES



PF7 Series

Bracket is designed for mounting KT-07 & KT-16 & KT-36 & KT-37 & KT-38 & KT-39 & KT-77 series sensor on ISO profile cylinder.

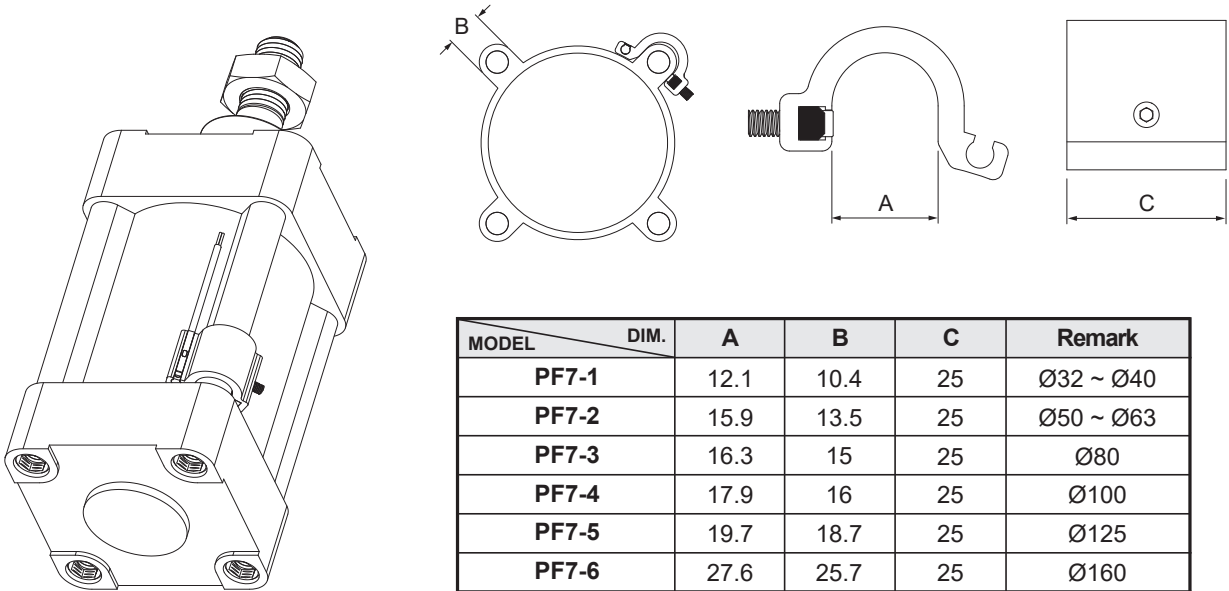

Unit : mm

DT7 Series

Bracket is designed for mounting KT-07 & KT-16 & KT-36 & KT-37 & KT-38 & KT-39 & KT-77 series sensor on Tie-Rod cylinder.

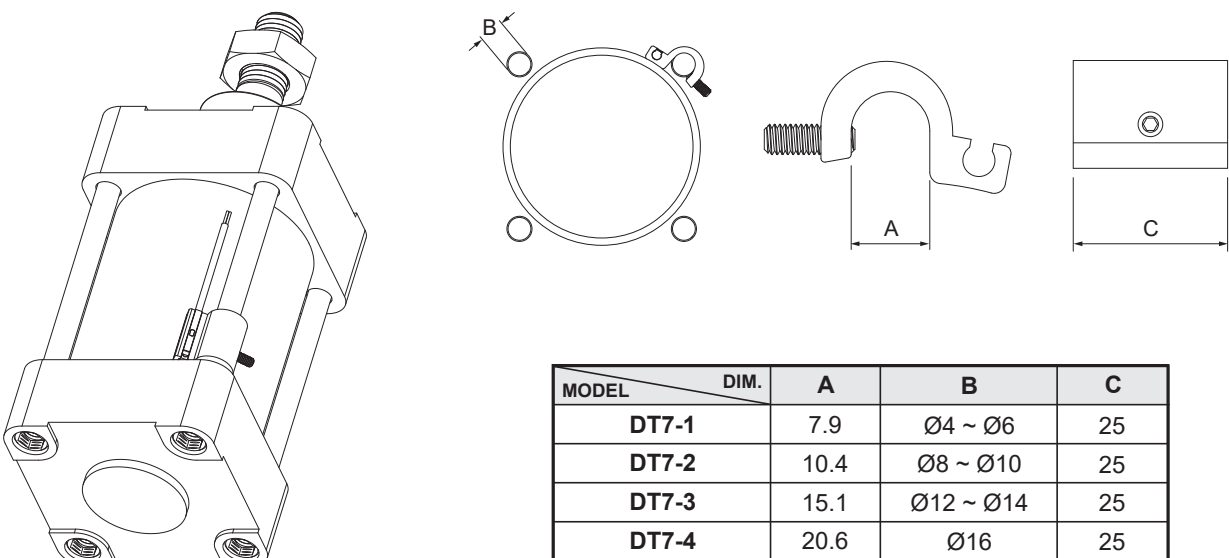

Unit : mm

BRACKET SERIES



PB Series

PB-01 & PB-03 bracket is designed for mounting KT-07 & KT-16 & KT-1001D series sensor on T-slot cylinder.
 PB-12 bracket is designed for mounting KT-07 & KT-16 & KT-36 & KT-37 & KT-38 & KT-39 & KT-77 & KT-1001D series sensor on T-slot cylinder.

■ PB-01 & PB-03

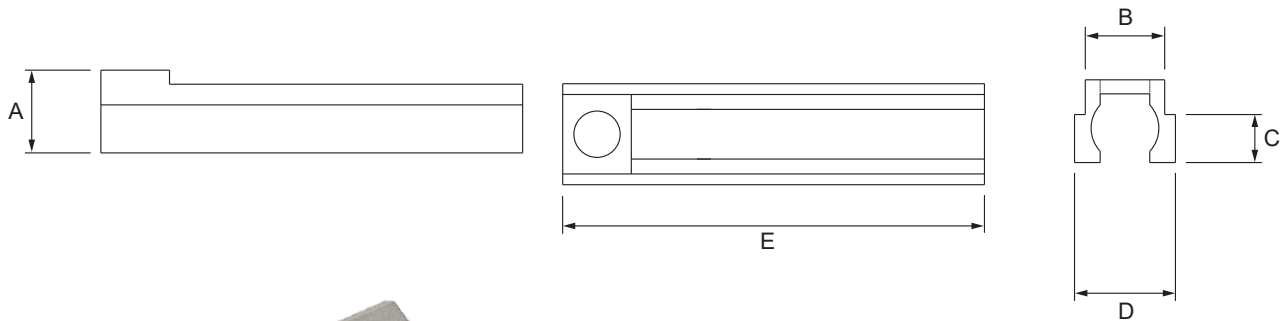

MODEL	DIM.	A	B	C	D	E	Groove Dimensions
PB-01		5.0	4.8	2.9	6.1	25.5	5.4 ± 0.3 3.4 ± 0.3
PB-03		5.0	4.8	3.8	6.1	25.5	$5^{+0.25}_{-0}$ $4^{+0.25}_{-0}$

Unit : mm

■ PB-12

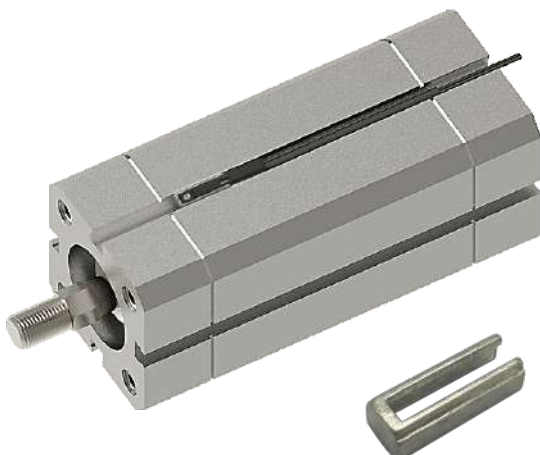
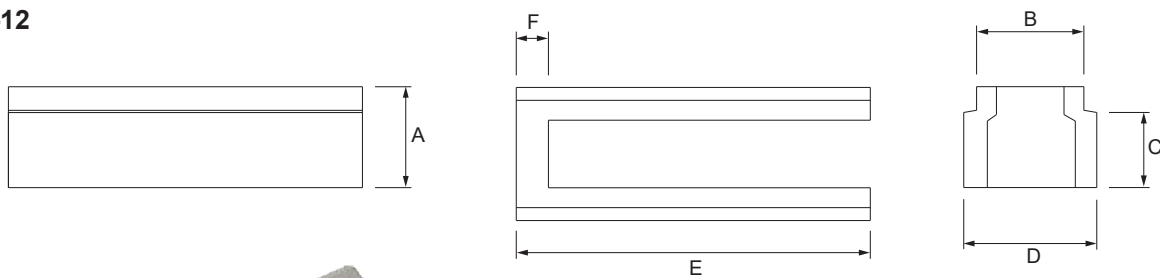

MODEL	DIM.	A	B	C	D	E	F	Groove Dimensions
PB-12		4.7	5.0	3.5	6.2	16.5	1.5	$5^{+0.25}_{-0}$ $4^{+0.25}_{-0}$

Unit : mm

CLAMP SERIES



PN Series

Clamp is designed for mounting KT-20 & KT-21 series sensor on round cylinder.

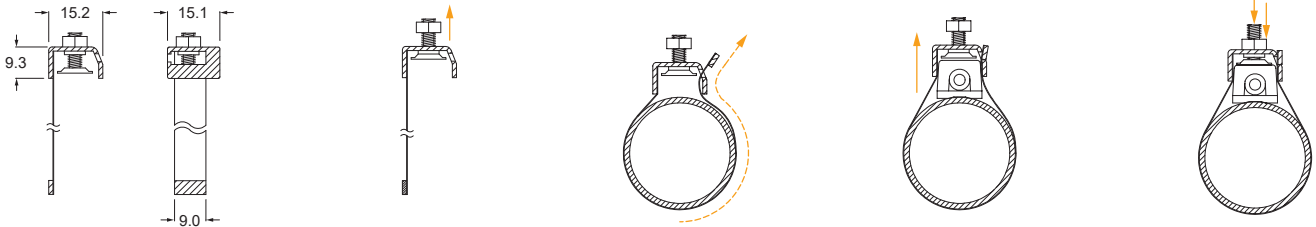

How To Mount

1 Step 1

Loosen screw & nut.

2 Step 2

Wrap the band around the cylinder & put the apex through the fastening hole.

3 Step 3

Pull up mounting head & place sensor under the mounting head.

4 Step 4

Swivel set screw to tighten band and fixing sensor. Finally swivel nut for steadying.

Cylinder Chart

Model	Bore Size	Barrel Material	Model	Bore Size	Barrel Material
PN-A16	Ø16	Aluminum	PN-S10	Ø10	Stainless
PN-A20	Ø20	Aluminum	PN-S12	Ø12	Stainless
PN-A25	Ø25	Aluminum	PN-S16	Ø16	Stainless
PN-A30	Ø30	Aluminum	PN-S20	Ø20	Stainless
PN-A32	Ø32	Aluminum	PN-S25	Ø25	Stainless
PN-A40	Ø40	Aluminum	PN-S32	Ø32	Stainless
PN-A50	Ø50	Aluminum	PN-S40	Ø40	Stainless
PN-A63	Ø63	Aluminum			

Unit : mm

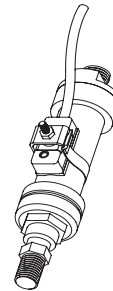

PN - S 2 0

Barrel Material

S : Stainless steel
A : Aluminum alloy

Bore Size

10 : Ø10 round cylinder
12 : Ø12 round cylinder
⋮
40 : Ø40 round cylinder

PH Series

Clamp is designed for mounting KT-20 & KT-21 series sensor on round cylinder.

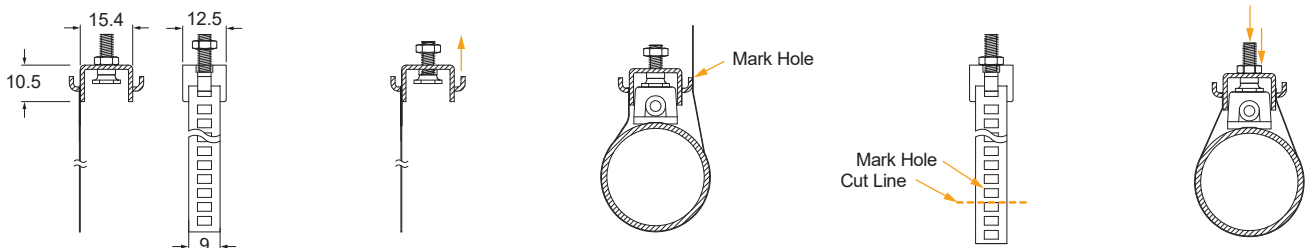

How To Mount

1 Step 1

Loosen screw & nut.

2 Step 2

Place sensor & wrap the band around the cylinder. Position the hook with the nearest hole on the band and mark the hole with a permanent marker.

3 Step 3

Remove mounting assembly. Cut the band at the nearest edge of next hole. (the one that's further away from the mounting head).

4 Step 4

Re-place the sensor & mounting assembly. Wrap the band & put the chosen hole on hook. Position the switch and tighten. Finally swivel nut for steadying.

PH - 1

Band No.

1 : For Ø6 ~ Ø63 round cylinder use.
2 : For Ø6 ~ Ø125 round cylinder use.

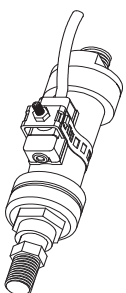

CLAMP SERIES



BK Series

Clamp is designed for mounting KT-05 & KT-15 series sensor on round cylinder.

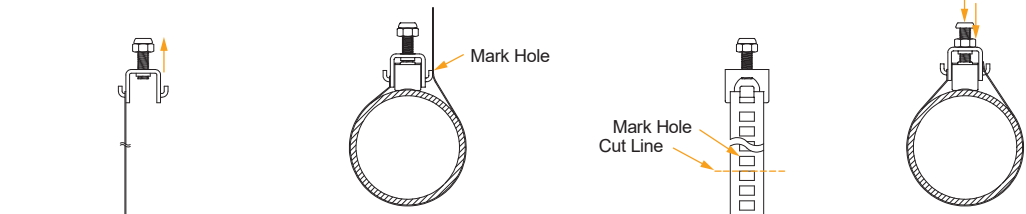
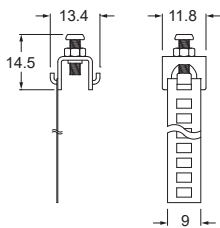

How To Mount

1 Step 1

Loosen screw & nut.

2 Step 2

Place sensor & wrap the band around the cylinder. Position the hook with the nearest hole on the band and mark the hole with a permanent marker.

3 Step 3

Remove mounting assembly. Cut the band at the nearest edge of next hole. (the one that's further away from the mounting head).

4 Step 4

Re-place the sensor & mounting assembly. Wrap the band & put the chosen hole on hook. Position the switch and tighten. Finally swivel nut for steadying.

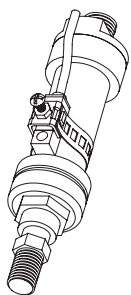

B K - **8 1**

Band No.

- 81 : For Ø6 ~ Ø32 round cylinder use.
- 82 : For Ø6 ~ Ø63 round cylinder use.

BS Series

Clamp is designed for mounting KT-48 series sensor on round cylinder.

How To Mount

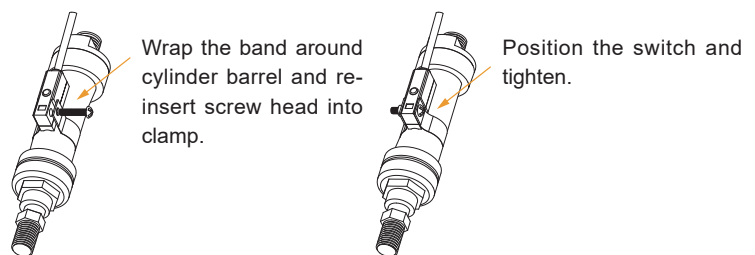
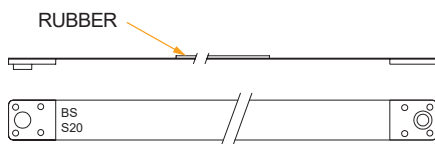

B S - **S 2 5**

Barrel Material

- S : Stainless steel
- A : Aluminum alloy

Bore Size

- 6 : Ø6 round cylinder
- 8 : Ø8 round cylinder
- ...
- 40 : Ø40 round cylinder

Cylinder Chart

Model	Bore Size	Barrel Material	O.D. (mm)	Model	Bore Size	Barrel Material	O.D. (mm)
BS-A20	Ø20	Aluminum	25	BS-S6	Ø6	Stainless	8.5
BS-A25	Ø25	Aluminum	30	BS-S8	Ø8	Stainless	10
BS-A30	Ø30	Aluminum	35	BS-S10	Ø10	Stainless	11
BS-A32	Ø32	Aluminum	37	BS-S12	Ø12	Stainless	13.2
BS-A40	Ø40	Aluminum	45	BS-S16	Ø16	Stainless	17
BS-A50	Ø50	Aluminum	55	BS-S20	Ø20	Stainless	21.6
BS-A63	Ø63	Aluminum	70	BS-S25	Ø25	Stainless	26.5
BS-A80	Ø80	Aluminum	87.7	BS-S32	Ø32	Stainless	33.6
				BS-S40	Ø40	Stainless	42

Unit : mm

BL-1 Series

Clamp is designed for mounting KT-40 & KT-50 series sensor on round cylinder.

Cylinder Chart

Bore Size	Barrel Material	O.D. (mm)	Recommended mounting hole	Bore Size	Barrel Material	O.D. (mm)	Recommended mounting hole
Ø10	Stainless	11	10	Ø30	Aluminum	35	26
Ø12	Stainless	13.2	11	Ø32	Stainless	33.6	24
Ø16	Stainless	17	14	Ø32	Aluminum	37	27
Ø20	Stainless	21.6	16	Ø40	Stainless	42	30
Ø20	Aluminum	25	19	Ø40	Aluminum	45	32
Ø25	Stainless	26.5	20	Ø50	Aluminum	55	40
Ø25	Aluminum	30	22	Ø63	Aluminum	70	50



How To Mount

Example : Use with Ø40 stainless body cylinder.

1 Step 1

Refer to the cylinder chart, make marking next to the 30th hole. (On the 31st hole, see below)

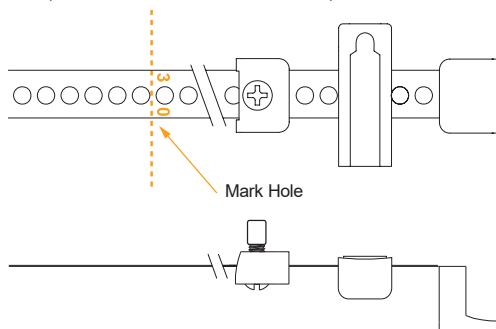

2 Step 2

Cut off excessive mounting band.

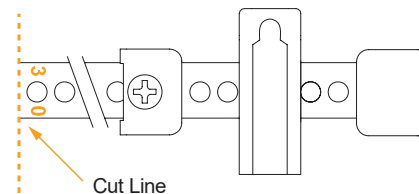

3 Step 3

Insert screw through screw fixture and the appropriate hole.

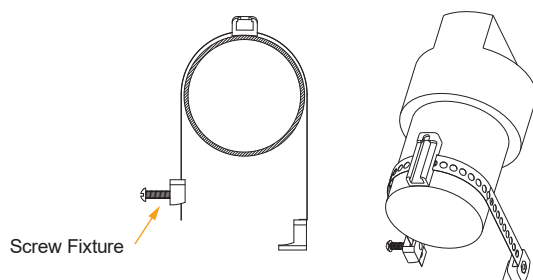

4 Step 4

Wrap the mounting band around the cylinder barrel and tighten the screw 3 ~ 5 turns.

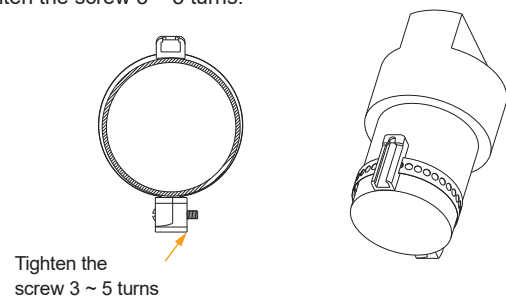

5 Step 5

Mount the sensor in the BL-1 series bracket and tighten.

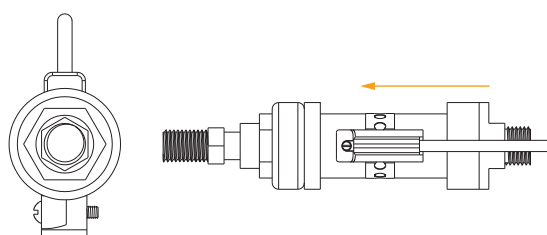

6 Step 6

Adjust sensor to the sensing position and tighten.

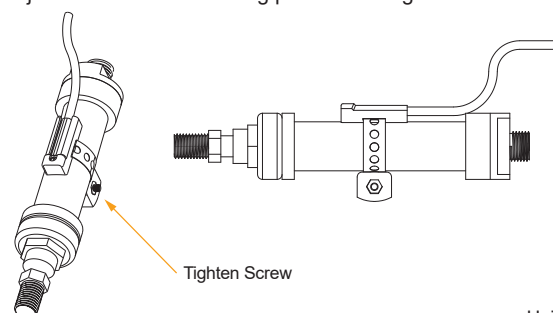

Unit : mm

BKC-1

BKC-1 is designed for mounting KT-07 & KT-36 & KT-77 series sensor on round cylinder.



How To Mount

Example : Use with Ø32 stainless body cylinder.

Refer to the clamp marking "Stainless steel 32", and cut off the excessive portion.

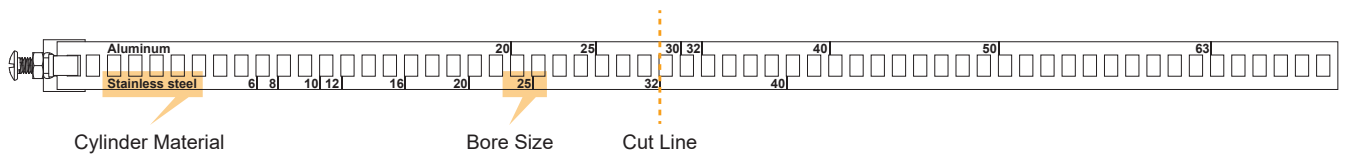

Installation Steps

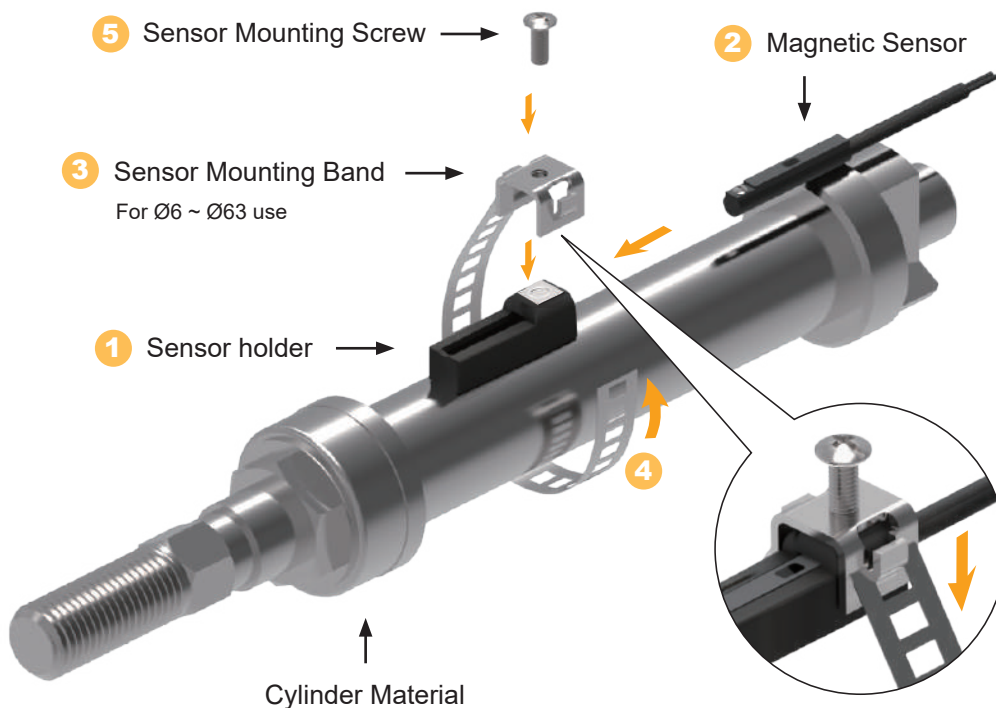

Unit : mm

BKT-1

BKT-1 is designed for mounting KT-65 & KT-75 series sensor on round cylinder.



How To Mount

Example : Use with $\varnothing 32$ stainless body cylinder.

Refer to the clamp marking "Stainless steel 32", and cut off the excessive portion.

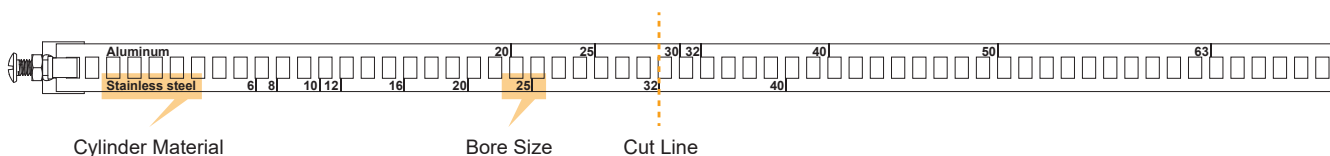

Installation Steps

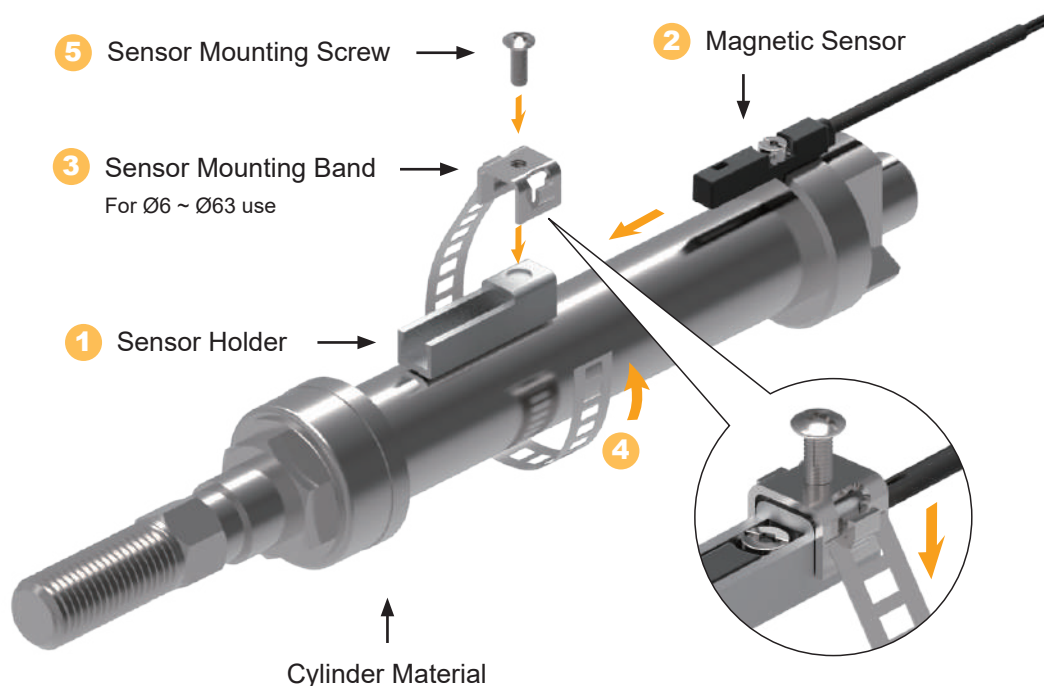

Unit : mm

FST

FST is designed for KT-32 & KT-40 & KT-50 & KT-65 & KT-75 series sensor on Tie-Rod cylinder.

Patented



FST

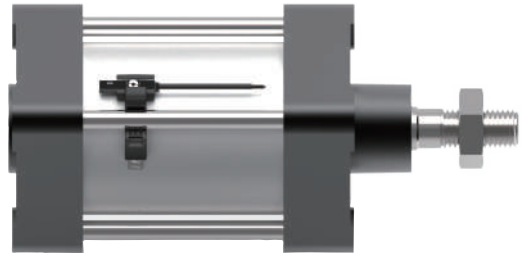

How to mount

1 Step 1

Fix sensor on bracket with 2mm hexagon wrench or flathead screwdriver.

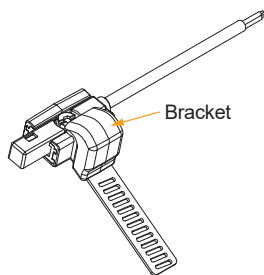

Bracket

2 Step 2

Insert the band between cylinder tube and Tie-Rod.

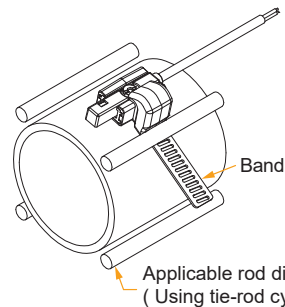

Band

Applicable rod diameter $\varnothing 6 \sim \varnothing 16$
(Using tie-rod cylinder range $\varnothing 32 \sim \varnothing 200$)

3 Step 3

Slide the retaining bracket onto the band.

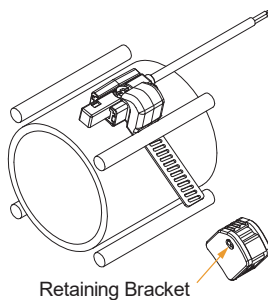

Retaining Bracket

4 Step 4

Adjust by moving bracket to most ideal sensing position and tighten screw. (Torque : 5 ~ 7 kgs).

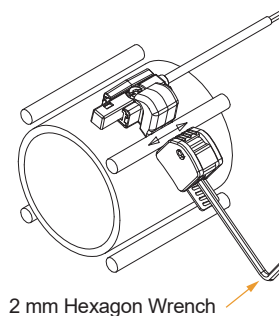

2 mm Hexagon Wrench

How to dismount

1 Step 1

Use 2 mm hexagon wrench to release the screw for 2 ~ 3 turns.

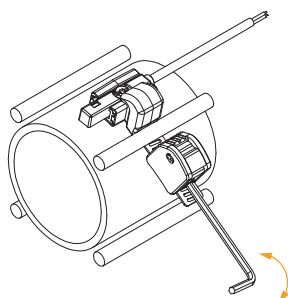

2 Step 2

Use 2 mm hexagon wrench to lift up the screw cap to remove the retaining bracket.

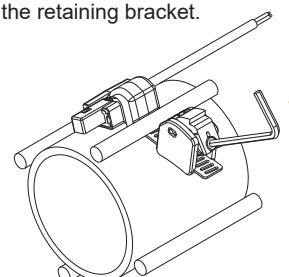

Anisotropic Rubber Magnet

MODEL	DIM.	A / $\begin{smallmatrix} +0.00 \\ -0.80 \end{smallmatrix}$	B / $\begin{smallmatrix} +0.80 \\ -0.00 \end{smallmatrix}$	C / ± 0.2
ME - 16 - 8 × 4		15.50	8.00	4.00
ME - 20 - 9 × 4		19.50	9.00	4.00
ME - 25 - 13 × 4		24.50	13.00	4.00
ME - 30 - 21 × 4		29.50	21.00	4.00
ME - 32 - 21 × 4		31.50	21.00	4.00
ME - 40 - 22 × 4		39.50	22.00	4.00
ME - 50 - 32 × 4		49.50	32.00	4.00
ME - 63 - 42 × 4		62.50	42.00	4.00
ME - 80 - 58 × 4		79.50	58.00	4.00
ME - 100 - 78 × 4		99.50	78.00	4.00
ME - 125 - 79 × 4		124.50	79.00	4.00
ME - 125 - 108 × 4		124.50	108.00	4.00
ME - 150 - 125 × 4		149.50	125.00	4.00
ME - 200 - 176 × 4		195.50	176.00	4.00

MODEL	DIM.	A / $\begin{smallmatrix} +0.00 \\ -0.80 \end{smallmatrix}$	B / $\begin{smallmatrix} +0.80 \\ -0.00 \end{smallmatrix}$	C / ± 0.2
ME - 16 - 8 × 5		15.50	8.00	5.00
ME - 20 - 9 × 5		19.50	9.00	5.00
ME - 25 - 13 × 5		24.50	13.00	5.00
ME - 30 - 21 × 5		29.50	21.00	5.00
ME - 32 - 21 × 5		31.50	21.00	5.00
ME - 40 - 22 × 5		39.50	22.00	5.00
ME - 50 - 32 × 5		49.50	32.00	5.00
ME - 63 - 42 × 5		62.50	42.00	5.00
ME - 80 - 58 × 5		79.50	58.00	5.00
ME - 100 - 78 × 5		99.50	78.00	5.00

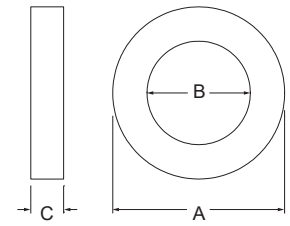

Unit : mm

Magnetic Property

- Residual flux density (Br) : 2300 - 2500 gauss
- Coercive force (iHC) : 3000 - 3800 Oe
(bHC) : 2000 - 2300 Oe
- Maximum energy product : 1.3 - 1.5 Mg.Oe

Physical Property

- Resistant power : 20 - 50 kgf / cm²
- Lengthen : 5 - 20 %
- Hardness (Shore D) : 30 - 50
- Specific gravity : 3.5 - 3.7 g / cm³
- Temperature range : -20 °C ~ +70 °C

Anisotropic Plastic Magnet

MODEL	DIM.	A / $\begin{smallmatrix} +0.00 \\ -0.30 \end{smallmatrix}$	B / $\begin{smallmatrix} +0.30 \\ -0.00 \end{smallmatrix}$	C / ± 0.2
PME - 20 - 9 × 4		19.50	9.00	4.00
PME - 25 - 13 × 4		24.50	13.00	4.00
PME - 30 - 21 × 4		29.50	21.00	4.00
PME - 32 - 21 × 4		31.50	21.00	4.00
PME - 40 - 22 × 4		39.50	22.00	4.00
PME - 50 - 32 × 4		49.50	32.00	4.00
PME - 63 - 42 × 4		62.50	42.00	4.00
PME - 80 - 58 × 4		79.50	58.00	4.00
PME - 100 - 78 × 4		99.50	78.00	4.00

MODEL	DIM.	A / $\begin{smallmatrix} +0.00 \\ -0.30 \end{smallmatrix}$	B / $\begin{smallmatrix} +0.30 \\ -0.00 \end{smallmatrix}$	C / ± 0.2
PME - 12 - 6 × 5		11.50	6.00	5.00
PME - 16 - 8 × 5		15.50	8.00	5.00
PME - 20 - 9 × 5		19.50	9.00	5.00
PME - 25 - 13 × 5		24.50	13.00	5.00
PME - 30 - 21 × 5		29.50	21.00	5.00
PME - 32 - 21 × 5		31.50	21.00	5.00
PME - 40 - 22 × 5		39.50	22.00	5.00
PME - 50 - 32 × 5		49.50	32.00	5.00
PME - 63 - 42 × 5		62.50	42.00	5.00
PME - 80 - 58 × 5		79.50	58.00	5.00
PME - 100 - 78 × 5		99.50	78.00	5.00

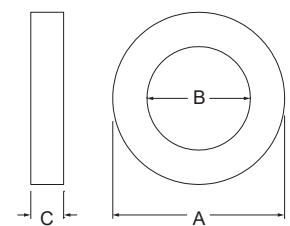

Unit : mm

Magnetic Property

- Residual flux density (Br) : 2500 - 3000 gauss
- Coercive force (iHC) : 2700 - 3100 Oe
(bHC) : 2400 - 2500 Oe
- Maximum energy product : 1.8 Mg.Oe

Physical Property

- Resistant power : 80 kgf / cm²
- Lengthen : 6.7 %
- Hardness (Shore D) : 120
- Specific gravity : 3.2 g / cm³
- Temperature range : -20 °C ~ +100 °C

M8 □ R Series



P.150

KM8 □ R Series



P.151

M8 □ QD Series



P.152

M8 □ SW Series



P.153

M12 □ R Series



P.154

M12 □ QD Series



P.155

※ Product surfaces with slight luminance non-uniformity, color cast, tiny scratching, little stains etc. are regarded as qualified products.

M8 □ R SERIES



Ordering Information

M 8 3 R - P U R - 2 M



Cable Length

2M : 2 Meters
5M : 5 Meters

Type of Connector

R : Female, Straight cable socket
RL : Female, Angle cable socket

Cable Material

PVC : Ø4.5 PVC cable
PUR : Ø4.5 PUR cable

Connector Series

M83 : M8 3Pin connector
M84 : M8 4Pin connector

Specifications

MODEL	M83R - □ M83RL - □	M84R - □ M84RL - □		
Female Pinout				
Characteristics				
Conductor Colors	1 : Brown 3 : Blue 4 : Black	1 : Brown 2 : White 3 : Blue 4 : Black		
Number Of Contacts	3	4		
Rated Voltage	60 V AC / DC			
Rated Current	3 A			
Contact Material	Gold plated brass			
Contact Bearer Material	PA			
Housing Material	PP			
Housing Color	Black			
Cable Material	PVC	PUR	PVC	PUR
Cable Color	Gray	Black	Gray	Black
Cable Conductor	24 AWG (0.22mm ²)			
Circuit	-			
Led Color	-			
Protection Class (IEC60529)	IP67			
Temperature Range	-20 ~ 80 °C			

Dimensions

■ M83R / M84R

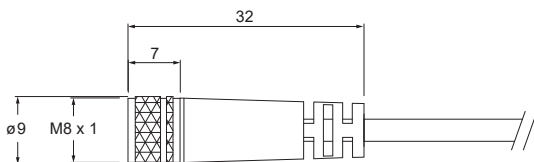

■ M83RL / M84RL

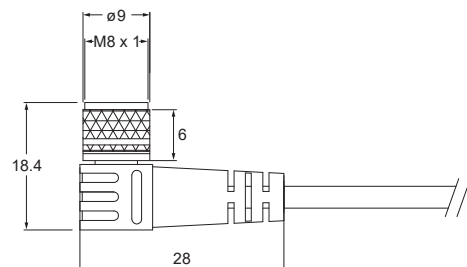

Unit : mm

Ordering Information

K M 8 3 R - P U R - 2 M



Cable Length

2M : 2 Meters
5M : 5 Meters

Type of Connector

R : Female, Straight cable socket
RL : Female, Angle cable socket





Cable material

PVC : Ø4.5 PVC cable
PUR : Ø4.5 PUR cable

Connector Series

KM83 : M8 3Pin connector
KM84 : M8 4Pin connector

Specifications

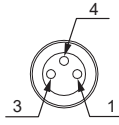
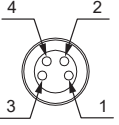
MODEL	KM83R -  KM83RL - 		KM84R -  KM84RL - 	
Female Pinout				
Characteristics				
Conductor Colors	1 : Brown 3 : Blue 4 : Black		1 : Brown 2 : White 3 : Blue 4 : Black	
Number Of Contacts	3		4	
Rated Voltage	60 V AC / DC			
Rated Current	3 A			
Contact Material	Gold plated brass			
Contact Bearer Material	PC + ABS			
Housing Material	TPV			
Housing Color	Black			
Cable Material	PVC	PUR	PVC	PUR
Cable Color	Gray	Black	Gray	Black
Cable Conductor	24 AWG (0.22mm ²)			
Circuit	-			
Led Color	-			
Protection Class (IEC60529)	IP67			
Temperature Range	-20 ~ 80 °C			

Dimensions

■ KM83R / KM84R

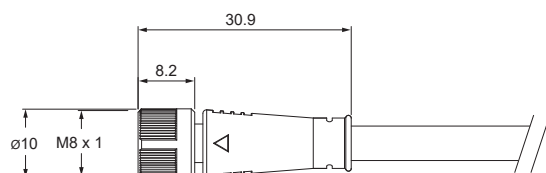

■ KM83RL / KM84RL

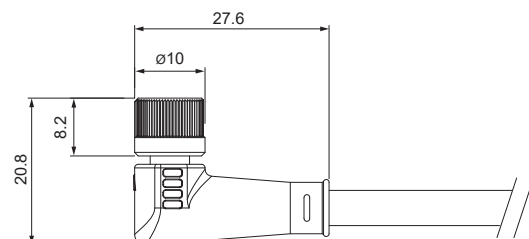

Unit : mm

Ordering Information

M 8 3 Q D - P U R - 2 M



Cable length

2M : 2 Meters
5M : 5 Meters

Type of Connector

QD : Male, Straight cable plug

Cable Material

PVC : Ø4.5 PVC cable
PUR : Ø4.5 PUR cable

Connector Series

M83 : M8 3Pin connector
M84 : M8 4Pin connector

Specifications

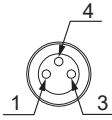
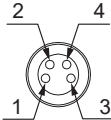
MODEL	M83QD - □		M84QD - □	
Male Pinout				
Characteristics				
Conductor Colors	1 : Brown 3 : Blue 4 : Black		1 : Brown 2 : White 3 : Blue 4 : Black	
Number Of Contacts	3		4	
Rated Voltage	60 V AC / DC			
Rated Current	3 A			
Contact Material	Gold plated brass			
Contact Bearer Material	PA			
Housing Material	PP			
Housing Color	Black			
Cable Material	PVC	PUR	PVC	PUR
Cable Color	Gray	Black	Gray	Black
Cable Conductor	24 AWG (0.22mm ²)			
Circuit	-			
Led Color	-			
Protection Class (IEC60529)	IP67			
Temperature Range	-20 ~ 80 °C			

Dimensions

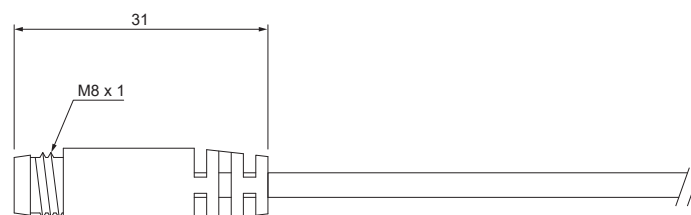

Unit : mm

M8 SW SERIES



Ordering Information

M 8 3 S W - P U R - 2 M



Cable Length

2M : 2 Meters
5M : 5 Meters

Type of Connector

SW : Male, swivel lock nut,
Straight cable plug
SWL : Male, swivel lock nut,
Angle cable plug

Cable Material

PVC : Ø4.5 PVC cable
PUR : Ø4.5 PUR cable

Connector Series

M83 : M8 3Pin connector
M84 : M8 4Pin connector

Specifications

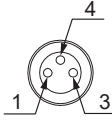
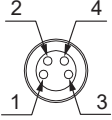
MODEL	M83SW - <input type="checkbox"/> M83SWL - <input type="checkbox"/>	M84SW - <input type="checkbox"/> M84SWL - <input type="checkbox"/>		
Male Pinout				
Characteristics				
Conductor Colors	1 : Brown 3 : Blue 4 : Black	1 : Brown 2 : White 3 : Blue 4 : Black		
Number Of Contacts	3	4		
Rated Voltage	60 V AC / DC			
Rated Current	3 A			
Contact Material	Gold plated brass			
Contact Bearer Material	PU			
Housing Material	PU			
Housing Color	Black			
Cable Material	PVC	PUR	PVC	PUR
Cable Color	Gray	Black	Gray	Black
Cable Conductor	24 AWG (0.22mm ²)			
Circuit	-			
Led Color	-			
Protection Class (IEC60529)	IP67			
Temperature Range	-20 ~ 80 °C			

Dimensions

M83SW / M84SW

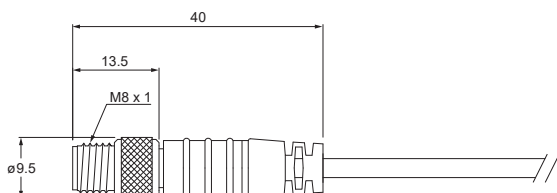

M83SWL / M84SWL

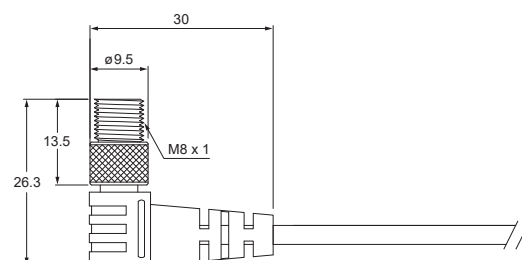

Unit : mm

M12 □ R SERIES



Ordering Information

M 1 2 3 R - P U R - 2 M



Cable Length

2M : 2 Meters
5M : 5 Meters

Type of Connector

R : Female, Straight cable socket
RL : Female, Angle cable socket

Cable Material

PVC : Ø5 PVC cable
PUR : Ø5 PUR cable

Connector Series

M123 : M12 3Pin connector
M124 : M12 4Pin connector
M125 : M12 5Pin connector

Specifications

MODEL	M123R - □ M123RL - □		M124R - □ M124RL - □		M125R - □ M125RL - □	
Female Pinout						
Characteristics						
Conductor Colors	1 : Brown 2 : N / C (NO connect) 3 : Blue 4 : Black 5 : N / C (NO connect)		1 : Brown 2 : White 3 : Blue 4 : Black 5 : N / C (NO connect)		1 : Brown 2 : White 3 : Blue 4 : Black 5 : Gray	
Number Of Contacts	3		4		5	
Rated Voltage	250 V AC / DC				60 V AC / DC	
Rated Current	4 A					
Contact Material	Gold plated brass					
Contact Bearer Material	PU					
Housing Material	PU					
Housing Color	Black					
Cable Material	PVC	PUR	PVC	PUR	PVC	PUR
Cable Color	Black					
Cable Conductor	22 AWG (0.33 mm ²)					
Circuit	-					
Led Color	-					
Protection Class (IEC60529)	IP67					
Temperature Range	-20 ~ 80 °C					

Dimensions

■ M123R / M124R / M125R

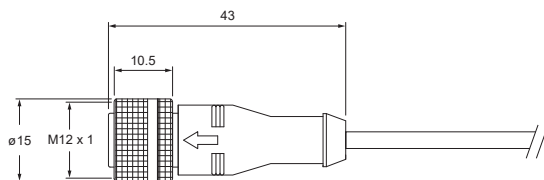

■ M123RL / M124RL / M125RL

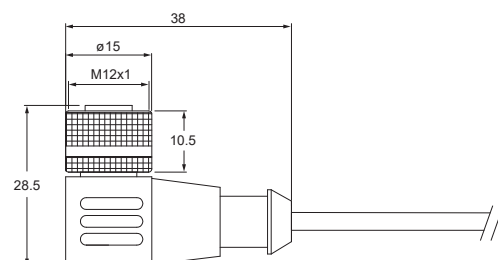

Unit : mm

M12 □ QD SERIES



Ordering Information

M 1 2 3 Q D - P U R - 2 M



Cable Length

2M : 2 Meters
5M : 5 Meters

Type of Connector

QD : Male, Straight cable plug
QDL : Male, Angle cable plug

Cable Material

PVC : Ø5 PVC cable
PUR : Ø5 PUR cable

Connector Series

M123 : M12 3Pin connector
M124 : M12 4Pin connector
M125 : M12 5Pin connector

Specifications

MODEL	M123QD - □ M123QDL - □	M124QD - □ M124QDL - □	M125QD - □ M125QDL - □	
Male Pinout				
Characteristics				
Conductor Colors	1 : Brown 3 : Blue 4 : Black	1 : Brown 2 : White 3 : Blue 4 : Black	1 : Brown 2 : White 3 : Blue 4 : Black 5 : Gray	
Number Of Contacts	3	4	5	
Rated Voltage	250 V AC / DC		60 V AC / DC	
Rated Current	4 A			
Contact Material	Gold plated brass			
Contact Bearer Material	PU			
Housing Material	PU			
Housing Color	Black			
Cable Material	PVC	PUR	PVC	PUR
Cable Color	Black			
Cable Conductor	22 AWG (0.33 mm ²)			
Circuit	-			
Led Color	-			
Protection Class (IEC60529)	IP67			
Temperature Range	-20 ~ 80 °C			

Dimensions

▪ M123QD / M124QD / M125QD

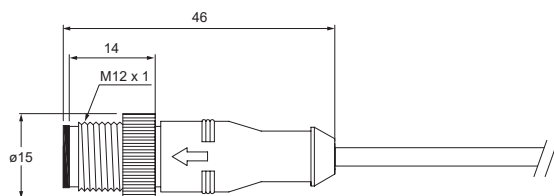

▪ M123QDL / M124QDL / M125QDL

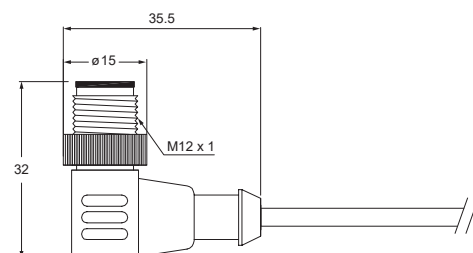

Unit : mm

Conversion Factors

Length

inch - mm	inch × 25.4 = mm	mm × 0.03937 = inch
inch - cm	inch × 2.54 = cm	cm × 0.3937 = inch
feet - m	feet × 0.3048 = m	m × 3.2808 = feet
yard - m	yard × 0.9144 = m	m × 1.0936 = yard

Weight

g - ounce	g × 0.0352 = oz	ounce × 28.349 = g
kg - pound	kg × 2.2046 = lb.	lb. × 0.4535 = kg

Pressure (Vacuum)

Pa - kgf / cm ²	Pa × 0.00001 = kgf / cm ²	kgf / cm ² × 98070 = Pa
kPa - kgf / cm ²	kPa × 0.0102 = kgf / cm ²	kgf / cm ² × 980.71 = kPa
MPa - kgf / cm ²	MPa × 1.02 = kgf / cm ²	kgf / cm ² × 0.098 = MPa
Pa - psi	Pa × 0.000145 = psi	psi × 6895 = Pa
kPa - psi	kPa × 0.145 = psi	psi × 6.895 = kPa
MPa - psi	MPa × 145 = psi	psi × 0.006895 = MPa
kPa - in. Hg	kPa × 0.2953 = in. Hg	in. Hg × 3.3864 = kPa
mmHg - in. Hg	mmHg × 0.03937 = in. Hg	in. Hg × 25.4 = mmHg
mmHg - Torr	mmHg + 760 = Torr	Torr - 760 = mmHg

Air Flow

SCFM - NI / min	SCFM × 28.57 = NI / min	NI / min × 0.035 = SCFM
-----------------	-------------------------	-------------------------

Effective Cross-Sectional Area - Cv Factor

mm ² = Cv	mm ² × 0.0542 = Cv	Cv × 18.45 = mm ²
----------------------	-------------------------------	------------------------------

Temperature

°C - °F	°C × 9 / 5 + 32 = °F	(°F - 32) × 5 / 9 = °C
---------	----------------------	--------------------------

Force

N - kgf	N × 0.10197 = kgf	kgf × 9.8067 = N
N - lbf	N × 0.22481 = lbf	lbf × 4.4482 = N
kgf - lbf	kgf × 2.20462 = lbf	lbf × 0.45359 = kgf

Torque

N. m - kgf. m	N. m × 0.10197 = kgf. m	kgf. m × 9.8067 = N. m
N. m - lbf. ft	N. m × 0.73756 = lbf. ft	lbf. ft × 1.3558 = N. m
kgf. m - lbf. ft	kgf. m × 7.233 = lbf. ft	lbf. ft × 0.13826 = kgf. m

Asia

Taiwan

KITA SENSOR TECH. CO., LTD.

NO.20, Wucyuan 8th Rd., Wugu Dist.,
New Taipei City 24891, Taiwan
TEL : +886-2-2299-3794
FAX : +886-2-2298-8704
E-mail : sales01@kita.com.tw
http : //www.kita.com.tw

China

KITA ELECTRONIC (CHANG SHU) CO., LTD.

Wang-Zhuang Industrial Park, Shanghu Zhen,
Chang-Shu City, Jiang-Su, China
TEL : +86-512-5243-8951~3
FAX : +86-512-5243-8950
E-mail : kita_changshu@kita.com.tw
http : //www.kitasensor.com

Japan Office

MING-SHING (JAPAN) INC.

4-7-21 Eifuku Suginami-Ku Tokyo
168-0064, Japan
TEL : +81-3-3323-8638
FAX : +81-3-3323-8048
E-mail : yuichinishihara-msg@nifty.com
http : //www.star-pneumatic.com

India Office

PARMA & PARMA (INDIA) PVT. LTD.

Office D-86, Okhla Industrial Area Phase-1,
New Delhi 110020
TEL : + 91-11-2681-1132/33
E-mail : marketing@parmaindia.com,
info@parmaindia.com
http : //www.parmaindia.com

Europe

France Office

DESBOIS BOTALAM INDUSTRIE (DBI)

95, Boulevard Aristide Briand
93106 MONTREUIL CEDEX, France
TEL : +33-1-4857-2024
FAX : +33-1-4857-1975
E-mail : dbi@dbigroupe.com
http : //www.dbigroupe.com

Italy Office

PARSEC SAS DI FIORE L. & C.

Via Giuseppe Parini, 2
20055 Vimodrone MI, Italy
TEL : +39-02-2740-1693
E-mail : commerciale.parsec@gmail.com
http : //www.parsecitalia.com

Scandinavian Office

HEMOMATIK AB

Lanna, Nyckelvagen 7
S-142 50 Skogas, Stockholm, Sweden
TEL : +46-8-771-3580
FAX : +46-8-771-6200
E-mail : erik@hemomatik.se
http : //www.hemomatik.se

America

America Office

ADSENS TECHNOLOGY, INC.

18310 Bedford Circle,
City of Industry, CA 91744-5971, U.S.A.
TEL : +1-626-854-2773
FAX : +1-626-854-8183
E-mail : sales@adsens.net
http : //www.adsens.net

Brazil Office

TAIPAN TECNOLOGIA

Rua Dos Andradas 1251 Sala 71
Porto Alegre-RS-Brasil
Cep : 90020-009
TEL : +55-51-3286-5277
FAX : +55-51-3225-0849
E-mail : vendas@taipantecnologia.com
http : //www.taipantecnologia.com

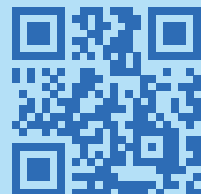

2020.06 PRINTING